

TM 5-2410-214-12

DEPARTMENT OF THE ARMY TECHNICAL MANUAL

---

TECHNICAL MANUAL

OPERATOR AND ORGANIZATIONAL

**MAINTENANCE MANUAL**

TRACTOR, FULLTRACK, LOW SPEED;

DIESEL ENGINE DRIVEN ; MEDIUM

DRAWBAR PULL; OSCILLATING TRACK

78-INCH GAGE

CATERPILLAR MODEL D-7E

NSN 2410-00-782-1130 w/WINCH

NSN 2410-00-926-3697 w/RIPPER

This copy is a reprint which includes current  
pages from Change I.

---

HEADQUARTERS, DEPARTMENT OF THE ARMY

30 JANUARY 1975

## **WARNING**

### **FIRE HAZARD**

**Be sure there are no open flames that may ignite the fuel vapors when the fuel tank is being filled.**

**Do not attempt to weld a fuel tank unless the tank has been thoroughly flushed or filled with water to eliminate combustible vapors.**

**Place adequate blocking under push beams before attempting to change the cutting edge on end bits, and while changing oil in the hydraulic system.**

## **DEATH**

**or severe injury**

**may be caused if tractor is adjusted while engine is in operation.**

**Use extreme caution in releasing the radiator cap when engine has been overheated.**

**Always lower dozer blade to ground (control lever in float position). Place range selector lever in NEUTRAL-START position and lock with the safety lever.**

**Ventilate area well after using fire extinguisher to eliminate fumes. They are toxic and deadly poisonous.**

**Cleaning solvent, PD 680, is a potentially DANGEROUS CHEMICAL. Do not use near open flame. Flash point of solvent is 100 F (38 C)-138 F (59 C).**

CHANGE }  
NO. 1 }

HEADQUARTERS  
DEPARTMENT OF THE ARMY  
WASHINGTON, DC, 22 January 1982

**OPERATOR AND ORGANIZATIONAL MAINTENANCE MANUAL  
TRACTOR, FULL TRACK, LOW SPEED; DIESEL ENGINE  
DRIVEN, MEDIUM DRAWBAR PULL; OSCILLATING TRACK,  
78 INCH GAGE CATERPILLAR MODEL D7E ROPS  
NSN 2410-01-050-9628 W/WINCH  
NSN 2410-01-050-9629 W/RIPPER**

TM 5-2410-214-12, 30 January 1975 is changed es follows:

1. Cover. The title is superseded as shown above.
2. Remove old pages and insert new pages as indicated below.
3. New or changed material is indicated by a vartical bar in the margin of the page.
4. Added or revised illustrations are indicated by a vertical bar adjacent to the illustration identification number.

Remove Pages	Insert Pages	Remove Pages	Insert Pages
i through iii	i through vi	None	3-21 through 3-27
1-1 through 1-10	1-1 through 1-2.2, 1-3 through 1-10	4-49 through 4-52	4-49 through 4-52
2-1 and 2-2	2-1 and 2-2	4-57 and 4-60	4-57 and 4-60
2-7 and 2-12	2-7 through 2.10.2,2-11 and 2-12	4-71 through 4-74	4-71 through 4-72.2,4-73 and 4-74.2
3-1 through 3-4	3-1 through 34	A - 1	A - 1
3-17 and 3-18	3-17 and 3-18	B-1 through B-6	B-1 through B-6
		None	D A 2 0 2 8 - 2 's

File this change sheet in front of the publication for reference purposes.

**By Order of the Secretary of the Army:**

**Official:**

**E. C. MEYER**  
*General, United States Army*  
*Chief of Staff*

**ROBERT M. JOYCE**  
*Brigadier General, United States Army*  
*The Adjutant General*

**Distribution:**

To be distributed in accordance with DA Form 12-25B, Operator Maintenance requirements for Tractor, Tracked, Medium.

TECHNICAL MANUAL }  
 No. 5-2410-214-12 }

HEADQUARTERS  
 DEPARTMENT OF THE ARMY  
 WASHINGTON, D. C., 30 January 1975

**OPERATOR AND ORGANIZATIONAL MAINTENANCE MANUAL**  
**TRACTOR, FULL TRACK, LOW SPEED; DIESEL ENGINE**  
**DRIVEN, MEDIUM DRAWBAR PULL; OSCILLATING TRACK,**  
**78 INCH GAGE CATERPILLAR MODEL D7E ROPS**  
**NSN 2410-01-050-9628 W/WINCH**  
**NSN 2410-01-050-9629 W/RIPPER**

			Paragraph	Page
CHAPTER	1	INTRODUCTION		
Section	I	General . . . . .	1-1 - 1-7	1-1
	II	Description and data . . . . .	1-8 - 1-10	1-1
CHAPTER	2	OPERATING INSTRUCTIONS . . . . .		
Section	I	Operating procedures . . . . .	2-1 - 2-5	2-1
	II	Operation under unusual conditions . . .	2-6 - 2-12	2-14
CHAPTER	3	OPERATOR/CREW MAINTENANCE INSTRUCTIONS		
Section	I	Lubrication instructions . . . . .		3-1
	11	Preventive maintenance checks and services . . . . .	3-1, 3-2	3-1
	III	Troubleshooting . . . . .	3-3	3-2
	IV	Maintenance procedures . . . . .	3-4 - 3-21	3-4
CHAPTER	4	ORGANIZATIONAL MAINTENANCE INSTRUCTIONS		
Section	I	Service upon receipt of equipment . . . .	4-1 - 4-3	4-1
	II	Movement to a new worksite . . . . .	4-4, 4-5	4-3
	III	Repair parts, special tools and equipment . . . . .	4-6, 4-7	4-3
	IV	Lubrication instruction . . . . .	4-8, 4-9	4-3
	V	Preventive maintenance checks and services . . . . .		4-4
	VI	Troubleshooting . . . . .		4-6
	VII	Radio interference suppression . . . . .	4-10 - 4-13	4-9
	VIII	Engine valve mechanism . . . . .	4-14, 4-15	4-13

\*This manual supersedes TM 5-2410-214-12, 6 June 1968 including all change.

Chapter 4 - Continued

Section		Paragraph	Page
IX	Engine lubrication system . . . . .	4-16 - 4-20	4-15
X	Controls and instruments . . . . .	4-21 - 4-23	4-24
XI	Fuel system . . . . .	4-24 - 4-32	4-27
XII	Cooling system . . . . .	4-33 - 4-41	4-38
XIII	Electrical system . . . . .	4-42 - 4-51	4-51
XIV	Transmission torque divider and steering clutches . . . . .	4-52 - 4-55	4-62
XV	Steering clutches and brakes . . . . .	4-56 - 4-58	4-68
XVI	Final drives . . . . .	4-59, - 4-60	4-70
XVII	Track and track frames . . . . .	4-61 - 4-63	4-72
XVIII	Frame and frame guards . . . . .	4-64 - 4-68	4-73
XIX	Body, hood and hull . . . . .	4-69 - 4-72	4-77
XX	Bulldozer and scarifiers . . . . .	4-73 - 4-76	4-79
XXI	Hydraulic system - bulldozer . . . . .	4-77 - 4-81	4-82
XXII	Winch . . . . .	4-82 - 4-86	4-83
XXIII	Ripper . . . . .	4-87 - 4-88	4-98
Appendix	A	References . . . . .	A-1
	B	MAINTENANCE ALLOCATION CHART. . . . .	B-1
	C	BASIC ISSUE ITEM LIST OR ITEMS TROOP INSTALLED OR AUTHORIZED. . . . .	C-1
Index. . . . .			I-1

LIST OF ILLUSTRATIONS

Number	Title	Page
1-1	Tractor, right rear three-quarter view with winch . . . . .	1-2
1-1.1	Tractor, ROPS left side view . . . . .	1-2.1
1-2	Tractor, right rear three-quarter view with ripper . . . . .	1-3
1-3	Tractor, left rear three-quarter view with winch . . . . .	1-7
1-4	Tractor, left rear, three-quarter view with ripper . . . . .	1-8
1-5	Tractor, right front three-quarter view . . . . .	1-9
1-6	Electrical system, schematic diagram (generator) (sheet 1 of 2). . . . .	1-10
1-6	Electrical system, schematic diagram (alternator) (sheet 2 of 2) . . . . .	1-11
2-1	Controls and instruments Serial no. 75E1 through 75E1300 (sheet 1 of 6) . . . . .	2-2
2-1	Controls and instruments Serial no. 75E1301 and up (sheet 2 of 6) . . . . .	2-3
2-1	Controls and instruments (sheet 3 of 6) . . . . .	2-3
2-1	Controls and instruments (sheet 4 of 6) . . . . .	2-4
2-1	Controls and instruments (sheet 5 of 6) . . . . .	2-5
2-1	Controls and instruments (sheet 6 of 6) . . . . .	2-6
2-2	Starting the tractor engine . . . . .	2-8
2-3	Steering the tractor. . . . .	2-10
2-4	Ripper control lever positions . . . . .	2-13

LIST OF ILLUSTRATIONS - Continued

Number	Title	Page
2-5	Ripper shank adjustment . . . . .	2-14
3-1	Air cleaner service . . . . .	3-5
3-2	Muffler and exhaust pipe removal . . . . .	3-6
3-3	Fuel tank drain valve and fuel line valve . . . . .	3-7
3-4	Fuel tank filter, strainer and fuel level gage . . . . .	3-8
3-5	Primary fuel filter service . . . . .	3-9
3-6	Draining final fuel filter . . . . .	3-10
3-7	Installing final fuel filter elements . . . . .	3-11
3-8	Priming the fuel system . . . . .	3-12
3-9	Cleaning the cooling system . . . . .	3-13
3-10	Generator belt adjustment . . . . .	3-14
3-11	Checking track adjustment . . . . .	3-15
3-12	Adjusting track . . . . .	3-15
3-13	Winch control adjustment . . . . .	3-16
3-14	Winch brake band adjustment . . . . .	3-17
3-15	Bulldozer, removal and installation . . . . .	3-18
3-16	Cutting edge end bits, removal and installation . . . . .	3-18
3-17	Scarifier teeth and shank replacement . . . . .	3-19
3-18	Shank protector and tip replacement . . . . .	3-20
3-19	ROPS, removal and installation . . . . .	3-21
3-20	Right front leg, removal and installation . . . . .	3-22
3-21	Left front leg, removal and installation . . . . .	3-23
3-22	Left mounting riser, removal and installation . . . . .	3-24
3-23	Right mounting riser, removal and installation . . . . .	3-25
3-24	Seat belt, removal and installation . . . . .	3-26
3-25	Seat belt, removal and installation . . . . .	3-27
4-1	Batteries . . . . .	4-1
4-2	Radio interference suppression components (sheet 1 of 4). . . . .	4-9
4-2	Radio interference suppression components (sheet 2 of 4). . . . .	4-10
4-2	Radio interference suppression components (sheet 3 of 4). . . . .	4-11
4-2	Radio interference suppression components (sheet 4 of 4). . . . .	4-12
4-3	Compression release and valve clearance adjustment . . . . .	4-14
4-4	Engine lubricating oil flow . . . . .	4-16
4-5	Timing gear lubrication . . . . .	4-17
4-6	Engine oil filter and base removal . . . . .	4-18
4-7	Engine oil filter and base disassembly . . . . .	4-19
4-8	Engine oil cooler removal . . . . .	4-20
4-9	Engine oil cooler disassembly and cleaning . . . . .	4-21
4-10	Engine breather and oil filter removal . . . . .	4-21
4-11	Engine breather disassembly . . . . .	4-22
4-12	Oil filter cover disassembly . . . . .	4-23
4-13	Turbocharger oil lines . . . . .	4-24
4-14	Governor and declerator controls . . . . .	4-25
4-15	G a g e s . . . . .	4-26
4-16	Time totalizing meter, removal and installation . . . . .	4-27
4-17	Flow of fuel. . . . .	4-28

LIST OF ILLUSTRATIONS - Continued

Number	Title	Page
4-18	Testing fuel injection valve . . . . .	4-29
4-19	Servicing fuel injection valves . . . . .	4-29
4-20	Fuel injection pump . . . . .	4-31
4-21	Fuel injection pump, removal and installation . . . . .	4-32
4-22	Removing fuel primer . . . . .	4-33
4-23	Fuel transfer pump, removal and installation . . . . .	4-34
4-24	Fuel lines . . . . .	4-35
4-25	Fuel tank cap and strainer . . . . .	4-35
4-26	Primary fuel filter removal and disassembly . . . . .	4-36
4-27	Final fuel filter housing removal and installation . . . . .	4-37
4-28	Glow plugs removal and installation . . . . .	4-38
4-29	Flow of coolant . . . . .	4-39
4-30	Radiator guard, removal and installation . . . . .	4-41
4-31	Water lines and fittings . . . . .	4-43
4-32	Removing thermostat . . . . .	4-45
4-33	Radiator sealed pressure overflow unit (sheet 1 of 2) . . . . .	4-47
4-33	Radiator sealed pressure overflow unit (sheet 2 of 2) . . . . .	4-48
4-34	Cap assembly, exploded view . . . . .	4-48
4-35	Removing and installing fan and generator belts . . . . .	4-49
4-36	Fan guard, removal and installation . . . . .	4-51
4-37	Replacing generator brushes . . . . .	4-52
4-38	Generator removal and installation . . . . .	4-53
4-39	Alternator . . . . .	4-54
4-40	Generator regulator removal and installation . . . . .	4-55
4-41	Wiring connections for polarizing generator . . . . .	4-56
4-42	Starting motor, removal and installation . . . . .	4-56
4-43	Switches and lights . . . . .	4-57
4-44	Electrical components . . . . .	4-61
4-45	Transmission, bevel gear, and steering clutch oil system . . . . .	4-63
4-46	Transmission pump, removal and installation . . . . .	4-64
4-47	Transmission hoses, lines, fittings, removal and installation (sheet 1 of 2) . . . . .	4-65
4-47	Transmission hoses, lines, fittings, removal and installation (sheet 2 of 2) . . . . .	4-66
4-48	Transmission filter, removal and installation (sheet 1 of 2) . . . . .	4-67
4-48	Transmission filter, removal and installation (sheet 2 of 2) . . . . .	4-68
4-49	Steering clutch brake adjustment . . . . .	4-69
4-50	Steering clutch linkage adjustment . . . . .	4-69
4-51	Sprocket hub bearing adjustment . . . . .	4-71
4-52	Track shoe replacement . . . . .	4-72
4-53	Guards - track roller frame and sprocket removal and installation . . . . .	4-73
4-54	Track roller guards, removal and installation . . . . .	4-74
4-55	Crankcase guards, removal and installation . . . . .	4-75



## LIST OF ILLUSTRATIONS - Continued

Number	Title	Page
<b>4-56</b>	Engine upper guard assemblies, removal and installation (sheet 1 of 3) . . . . .	4-75
<b>4-56</b>	Engine upper guard assemblies, removal and installation (sheet 2 of 3). . . . .	4-76
4-56	Engine upper guard assemblies, removal and installation (sheet 3 of 3). . . . .	4-76
4-57	Floor plates, removal and installation . . . . .	4-77
4-58	Toolbox, removal and installation . . . . .	4-78
4-59	Seat, removal and installation . . . . .	4-79
4-60	Bulldozer blade assembly, removal and installation . . . . .	4-80
4-61	Push arms, removal and installation . . . . .	4-81
4-62	Scarifier housing, removal and installation . . . . .	4-82
4-63	Dozer, hydraulic pump, removal and installation . . . . .	4-83
4-64	Hydraulic system hoses, lines and fittings, removal and installation (sheet 1 of 4) . . . . .	4-85
4-64	Hydraulic system hoses, lines and fittings, removal and installation (sheet 2 of 4) . . . . .	4-86
4-64	Hydraulic system hoses, lines and fittings, removal and installation (sheet 3 of 4) . . . . .	4-87
4-64	Hydraulic system hoses, lines and fittings, removal and installation (sheet 4 of 4) . . . . .	4-88
4-65	Dozer hydraulic system tank and filter (sheet 1 of 2) . . . . .	4-89
4-65	Dozer hydraulic system tank and filter (sheet 2 of 2) . . . . .	4-90
4-66	Hydraulic control lever and linkage . . . . .	4-92
4-67	Winch, removal and installation . . . . .	4-94
4-68	Winch pump, removal and installation . . . . .	4-95
4-69	Winch brake band, removal and installation . . . . .	4-96
4-70	Winch cable installation . . . . .	4-97
4-71	Hydraulic hose, removal and installation . . . . .	4-98
4-72	Ripper beam and shank . . . . .	4-98
4-73	Link arm, removal and installation . . . . .	4-99
4-74	Cylinder, removal and installation . . . . .	4-100
4-75	Mounting bracket, removal and installation . . . . .	4-101

## CHAPTER 1

## INTRODUCTION

## Section I. GENERAL

**1-1. Scope**

a. This manual is published for use by personnel to whom the Caterpillar Model D-7E ROPS Tractor (figs 1-1, 1-1.1, 1-2, 1-3, 1-4 and 1-5) is issued. It provides information on the operation and organizational maintenance of the equipment. Also included are descriptions of main units and their functions in relationship to other components.

b. Appendix A contains a list of publications applicable to this manual. Appendix B contains the list of basic issue items authorized the operator of this equipment and the list of maintenance and operating supplies required for initial operation. Appendix C contains the maintenance allocation chart.

c. Numbers in parentheses following nomenclature callouts on illustrations indicate quantity; numbers preceding nomenclature callouts indicate preferred maintenance sequence.

**1-2. Maintenance forms and records**

Maintenance forms and records that you are required to use are explained in TM 38-750.

**1-3. Reporting of Errors**

You can help improve this publication. If you find any, mistake or if you know of a way to improve the procedures, please let us know. Mail your letter, DA Form 2028 (Recommended Changes to Publication and Blank Forms), or DA Form 2028-2 located in the back of this publication direct to: US Army Tank-Automotive Command, ATTN: DRSTA-MB, Warren, MI 48090. A reply will be furnished to you.

**1-4. Equipment Serviceability Criteria**

Refer to TM 5-2400-200-ESC for Equipment Serviceability Criteria.

**1-5. Basic Issue Items and Items Troop Installed or Authorized List**

There are troop installed items.

**1-6. Destruction of Army Materiel to Prevent Enemy Use**

Instructions for destruction of materiel to prevent enemy use are contained in TM 750-244-3.

**1-7. Administrative Storage**

Instructions for administrative storage are contained in TM 740-90-1.

## Section II. DESCRIPTION AND DATA

**1-8. Description**

a. The Model D-7E ROPS is a full-tracked, low speed, medium drawbar pull tractor. The tractor is powered by a four cylinder, four stroke cycle,

turbocharged diesel engine, equipped with a 24-volt electric starter.

b. Power from the diesel is transmitted by the flywheel to the torque divider and from the torque

divider output shaft through the universal joint to the transmission input shaft. The transmission output shaft is splined to a transfer gear within the transfer case. The transfer gear drives the bevel pinion. From the bevel pinion, power is transmitted through the bevel gear to the steering clutches then through the final drives to the tracks.

c. Power shift transmission provides 3 forward and 3 reverse speed ranges. The tractor is steered by hand levers that operate hydraulic control valves to actuate the steering clutches. Foot pedals control mechanically operated steering clutch brakes. A hand operated brake lock control is provided to lock one or both steering

clutch brakes in the applied position to hold the tractor on slopes.

d. The working tools include hydraulically controlled bulldozer blade with backrip scarifier, rear mounted winch, and ripper.

e. The Roll Over Protection Structure (ROPS) is designed to protect the driver in case of a roll-over or being hit by a falling object. The ROPS is located on both left and right fenders.

1-9. Tabulated Data

a. Identification. Caterpillar Model D-7E ROPS Tractor has information plates and decals as listed in table 1-1.

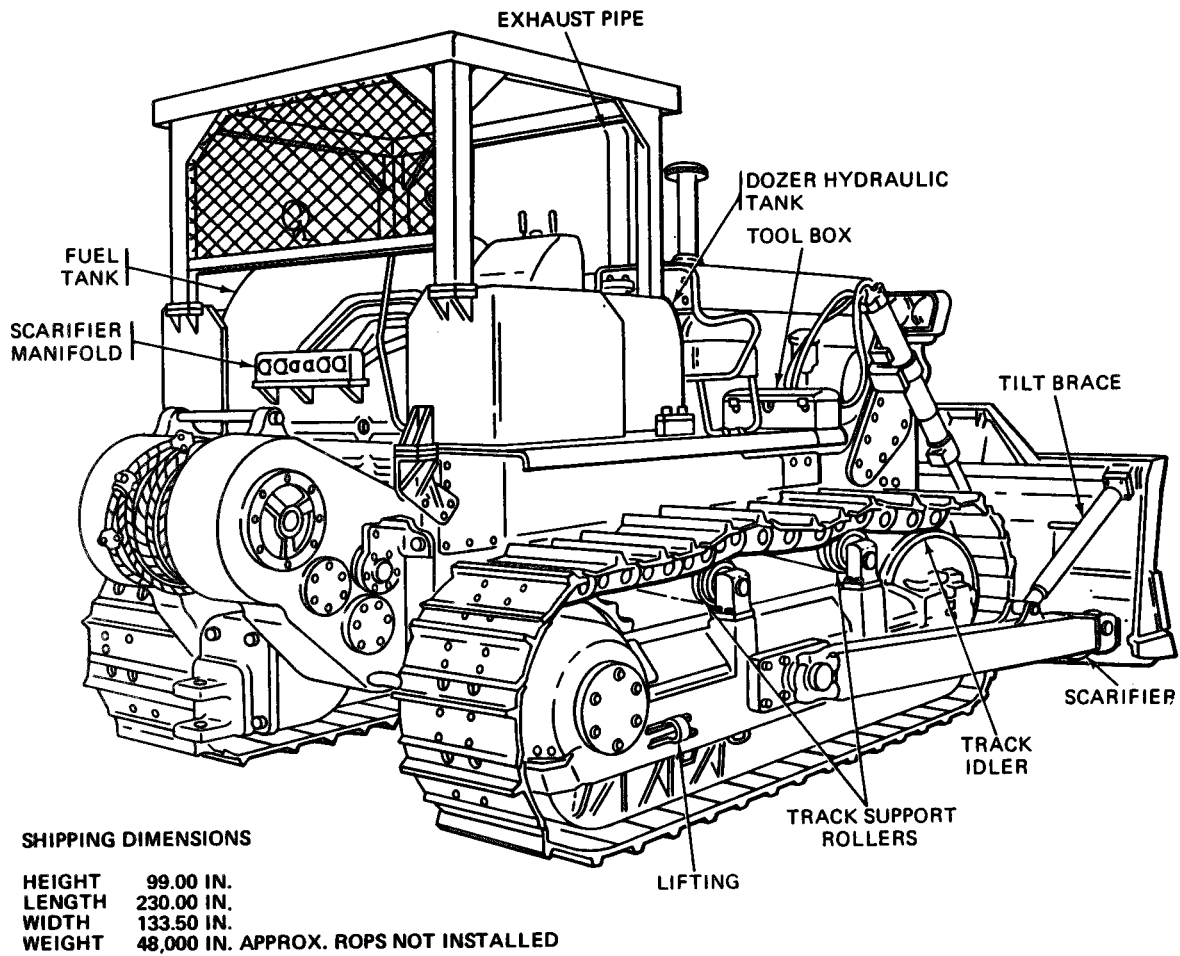

TA 178525 ■

Figure 1-1. Tractor right rear three quarter view with winch (Serial Nos. 75E1 and up).

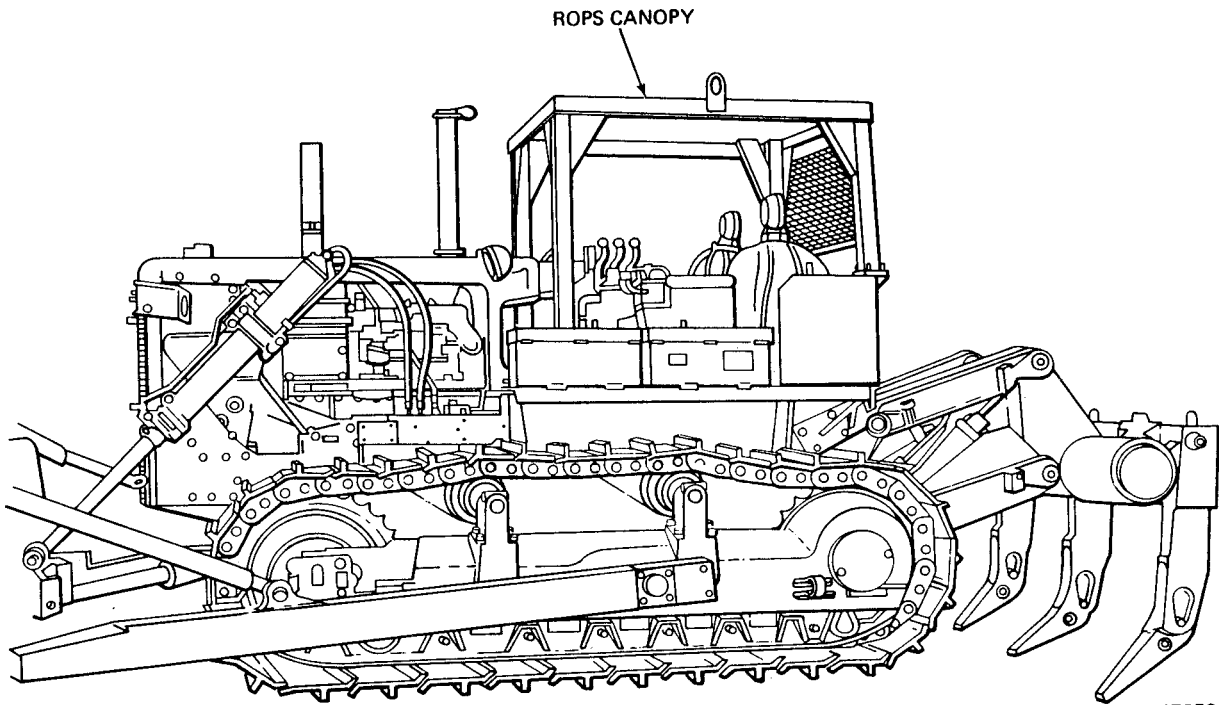

TA 178526 ■

*Figure 1-1.1. Tractor with ROPS.*

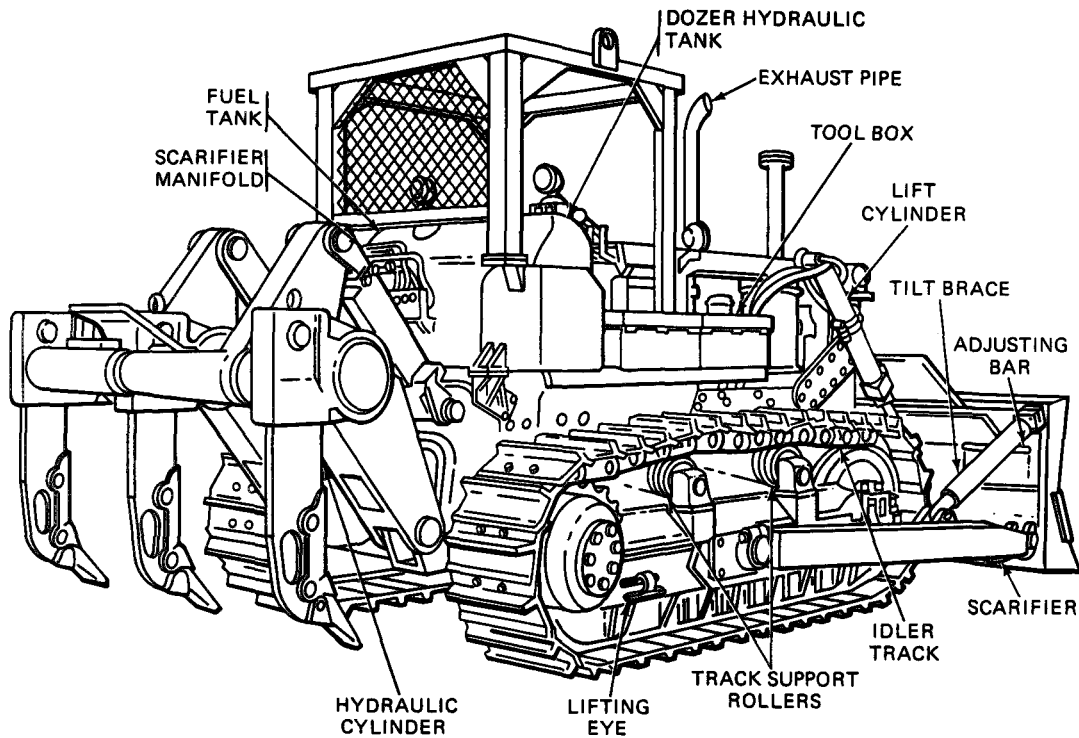

TA 178527 ■

Figure 1-2. Tractor, right rear three-quarter view with ripper. (Serial Nos. 75E1 and up).

Table 1-1. Identification and Information Plates and Transfers

Item	Description	Location
1	DECAL— Made by Caterpillar Tractor Co.	
2	PLATE— Fuel injection equipment	Fuel injection pump
3	PLATE— Serial No. (5 used)	
4	PLATE— Transmission number	Transmission case-top side
5	DECAL— Tractor patent	Right side of seat
6	FILM TRANSFER— Engine patent	Diesel air cleaner
7	PLATE — Hydraulic service instructions	Top of tank assembly adjacent to Serial plate
8	PLATE— Warning-operate at low idle	Front of dash
9	PLATE— Filter instruction	R. H. engine side sheet
10	PLATE — Air cleaner service instruction	L. H. engine side sheet
11	PLATE— Warning-rack settings	Front of dash
12	PLATE— Information	Hydraulic tank cap
13	PLATE— Warning-track adjustment	Recoil rod assembly
14	PLATE— Front floodlights switch	Instrument panel
15	PLATE— Rear floodlight switch	Instrument panel
16	PLATE— Front hood light switch	Instrument panel
17	PLATE— Instrument lights switch	Instrument panel
18	PLATE — Heat and start switch	Instrument panel
19	PLATE — Identification- scraper control lines	Fuel tank
20	PLATE— Transportation data	Battery box side
21	STENCIL— U. S. Army registration numbers	Both sides of hood
22	PLATE— Warning-Spring loaded cover	Decelerator housing cover

Item	Description	Location
23	PLATE—Warning	Track adjusting access doors
24	PLATE—Lower raised equipment	Front of dash
25	PLATE—Lock gear shift and brakes	Top of console body
26	PLATE	Top of dash
27	STENCIL, C. G.	Both sides of tractor
28	PLATE—Starting instructions	Top of console body
29	PLATE—Winch operation	Winch
30	PLATE—Winch lubrication	Winch
31	Winch nameplate	Winch
32	PLATE—Identification-serial number	Ripper beam assembly
33	PLATE—Identification-serial number	Bulldozer
34	PLATE—Instruction-transportation data	Battery box side
35	PLATE—Instruction-warning	Ripper mounting bracket
36	TRANSFER—Ripper patent	Ripper

b. Tabulated data

(1) Tractor

	<i>English</i>	<i>Meters</i>
Weight tractor only (SN 75E1 through 75 E1300)	31,200 lbs	14,040 kgs
Weight tractor only (SN 75E1301 and up)	31,870 lbs	14,342 kgs
Length	178 in	445 cm
Overall	w/winch 230 in	575 cm
Width	133.50 in	334 cm
Width, without mold board, push beams and trunnions ( SN 75E1 through 75E1300)	104.00 in	260 cm
Width, without moldboard, push beams and trunnions (SN 75 E1301 and up)	100.00 in	250 cm
Height (top of lights) (SN 75E1 through SN 75E1300)	98.00 in.	245 cm
Height (top of lights) (SN 75E1301 and up)	96.00 in.	140 cm
Ground clearance	15.25 in	38.12 cm
Drawbar height (centerline of jaw)	19.62 in	4905 cm
Winch reversible rear, 1 drum		
Ripper rear mlunted, 3 shanks		
Bulldozer Hydraulic		

(2) Diesel engine

Manufacture	Caterpillar	
Number of cylinders	4	
Bore	5.75 in	14.37 cm
Stroke	8.00 in	20.00 cm
Crankshaft (viewed from fan end)	Clockwise	
Firing order	1-3-4-2	
	5	
Number of main bearing piston displacement	821 cu in	13,456.19 cc
Compression ratio	15.7 to 1	
Rated horsepower	165 hp	167.31 hp
Low idle speed	625 rpm	
High idle speed	1340 rpm	
Governed full load speed	1200 rpm	
Batteries Caterpillar Part No.	4H2664)	
Quantity	4	
Type	12 volt	

(3) Winch

( a ) Drum size

Barrel diameter	12 in	30 cm
Flange diameter	22.5 in	56.25 cm
Barrell length	12.37	30.93 cm

( b ) Cable capacity

7/8 inch (2.18 cm) line	382 ft	111.5 m
1 inch (2.5 cm) line	293	88.7 m

<b>( c ) Ferrule size</b>		<i>English</i>	<i>Metric</i>
7/8 inch (2.18 cm) J7			
1 inch (215 cm) J8			
 (d) Hydraulic system pump gear type,			
9.5 gpm (.5985 liters per see) at 1450 rpm			
Maximum operating pressure	225 psi	158,197 kgs per sq meter	
Valve	Two spool		
Filter	50 mesh screen cartridge		
 (e) Weight			
Weight	2590 lbs	1150.50 kg	
 (4) Ripper			
Weight, shipping (approximate)	6000 lbs.	2700 kg	
Length	3 ft 6 in	1.06 meters	
Width	8 ft 4 7/8 in	252.5 cm	
Height	7 ft 6 5/8 in	226.5 cm	
Ground clearance under beam:			
Ripper raised	47.0 in	117.5 cm	
Ripper lowered	8.0 in	20.0 cm	
Beam length	7 ft 1 in	212.5 cm	
Beam section	12.0 in	30 cm	
Ground clearance under teeth (fully raised)	14.0 in	35 cm	
Maximum depth of penetration	25.0 in	62.5 cm	
Number of teeth 1, 2, or 3 tooth spacing:			
With two teeth	78 in	195 cm	
With three teeth	39 in	97.5 cm	
Hydraulic cylinders, double acting bore and stroke	6 in by 19 11/16 in	15 cm by 49.15 cm	
 (5) Capacities			
Transmission, torque converter and steering clutch system	27.0 gal	102.19 liters	
Final drives (2)	8.50 gal ea	32.17 liters	
Engine crankcase with filters	7.50 gal	28.38 liters	
Cooling system	20.0 gal	75.7 liters	
Fuel tank	116.0 gal	439 liters	
Hydraulic system	23.0 gal	87105 liters	
Winch transmission	16.0 gal	60.56 liters	
 (6) Adjustment data			
Generator drive belt tension	9/16 in & 13/16 in midway between pulleys	1.4 cm & 2.0 midway between pulleys	
Track	1 1/2 to 2 in above support pulley	3.75 cm to 5 cm above support pulley	
 (7) Nut and bolt torque data			
Cylinder head 5/8 in (1.56 cm) nuts			
first time	60 lb-ft	8.298 kg meters	
second time	120 lb-ft	16.59 kg meters	
7/8 in. (2.18 cm) nuts			
first time	150 lb-ft	20.74 kg meters	
second time	300 lb-ft	41.48 kg meters	
Fuel injection line nut	25 -35 lb-ft	3.45—4.61 kg meters	
Ripper mounting bracket stud nuts	1500 lb-ft	197.70 kg meters	
 (8) Electrical system schematic diagram.			
The electrical system components and circuits are shown on figure 1-6.			



	<i>English</i>	<i>Metric</i>
(9) Dimensions with ripper installed.		
Shipping height . . . . .	99.00 in	247.5 cm
Shipping length . . . . .	284.00in	710 cm
Shipping width . . . . .	133.50in	333.7 cm
Shipping weight . . . . .	52.350 lb	23,557 kg
	(Approx)	(Approx)

(10) Roll Over Protection Structure.

Weight - Shipping (approx.) . . . . .	1230 lb	557.93 kg
Length . . . . .	68.5 in	171.25 cm
Width. . . . .	60 in	150 cm
Height . . . . .	61.25 in	153.13 cm

**1-10** Difference in Models

a. This manual covers Caterpillar Model; D-7E ROPS tractor with winch or ripper.

b. Unless serial numbers are indicated, the information in this manual applies to all Model D-7E ROPS tractors. When the information given applies to a tractor in a particular serial numbered group it will be so indicated.

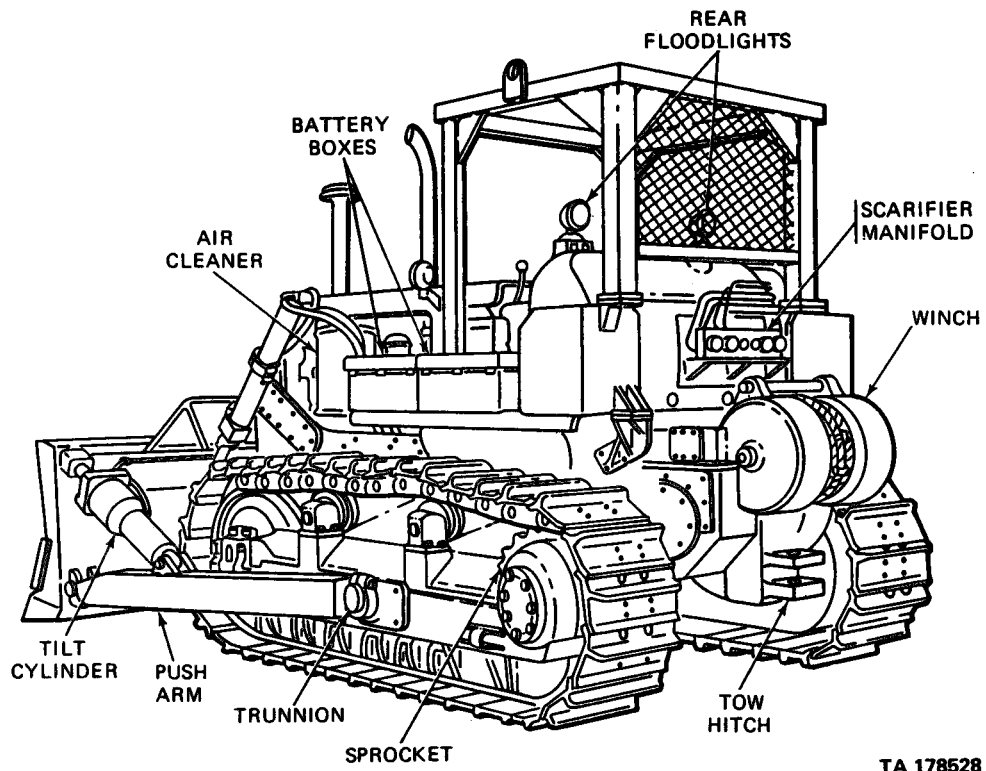

TA 178528 ■

Figure 1-3. Tractor, left rear three-quarter view with (Serial Nos. 75E1 and up).

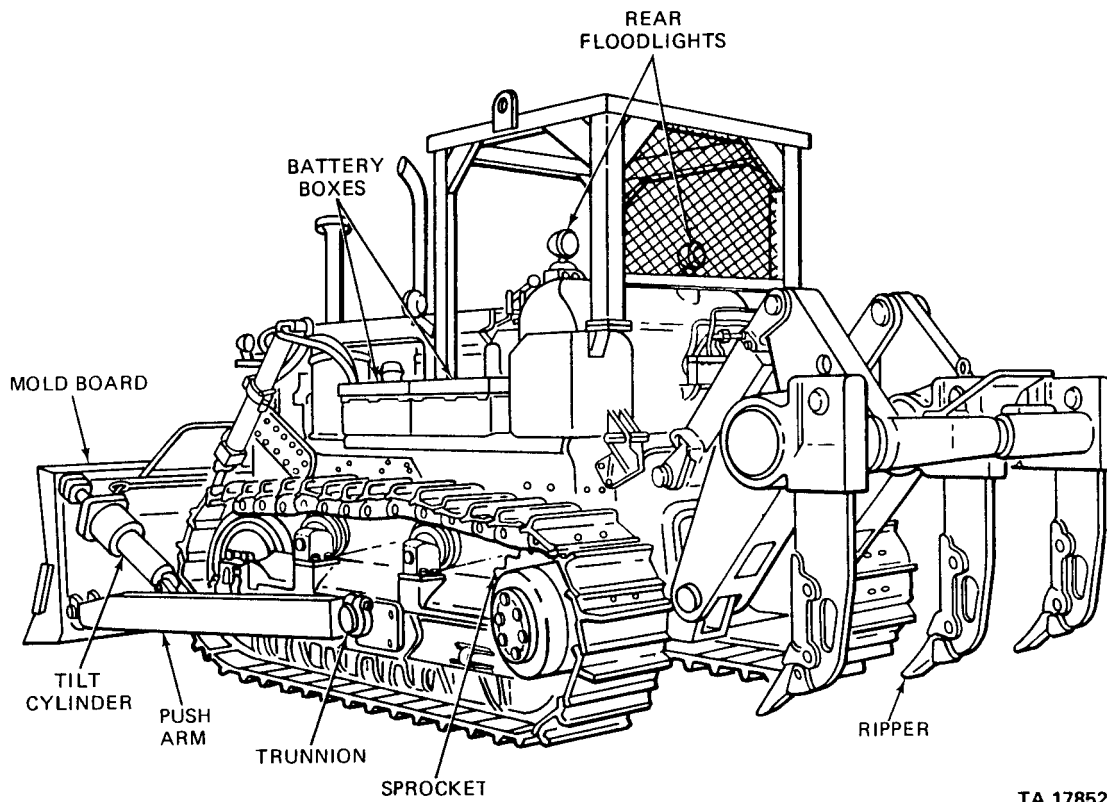

TA 178529 ■

Figure 1-4. Tractor, left rear three-quarter view with ripper (Serial Nos. 75E1 and up).

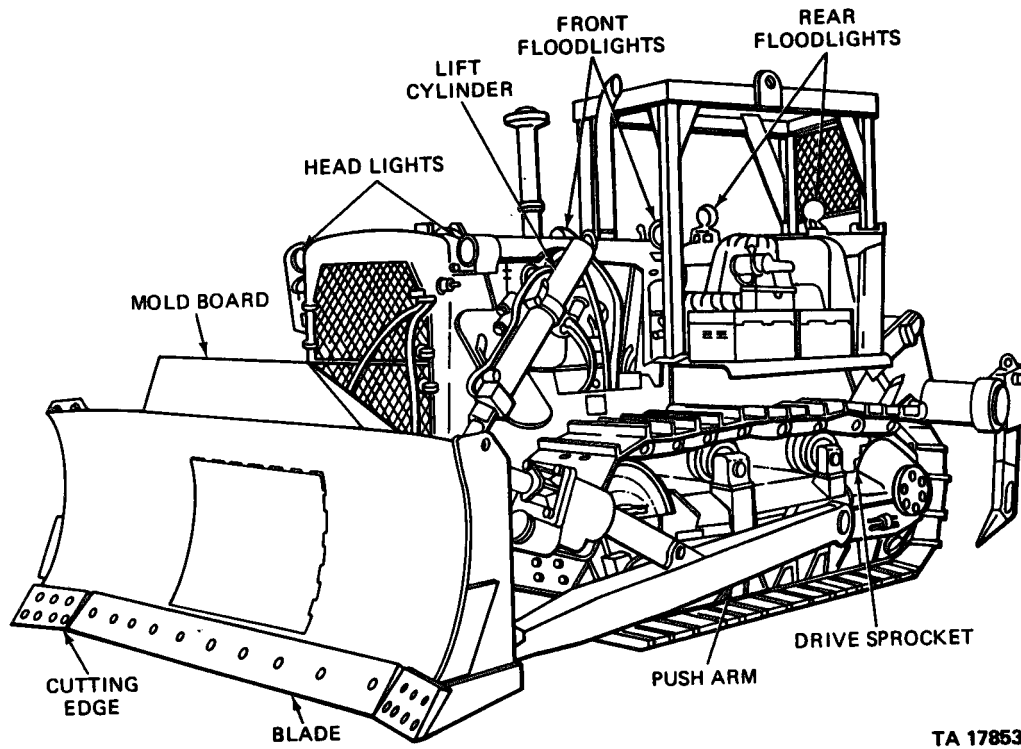
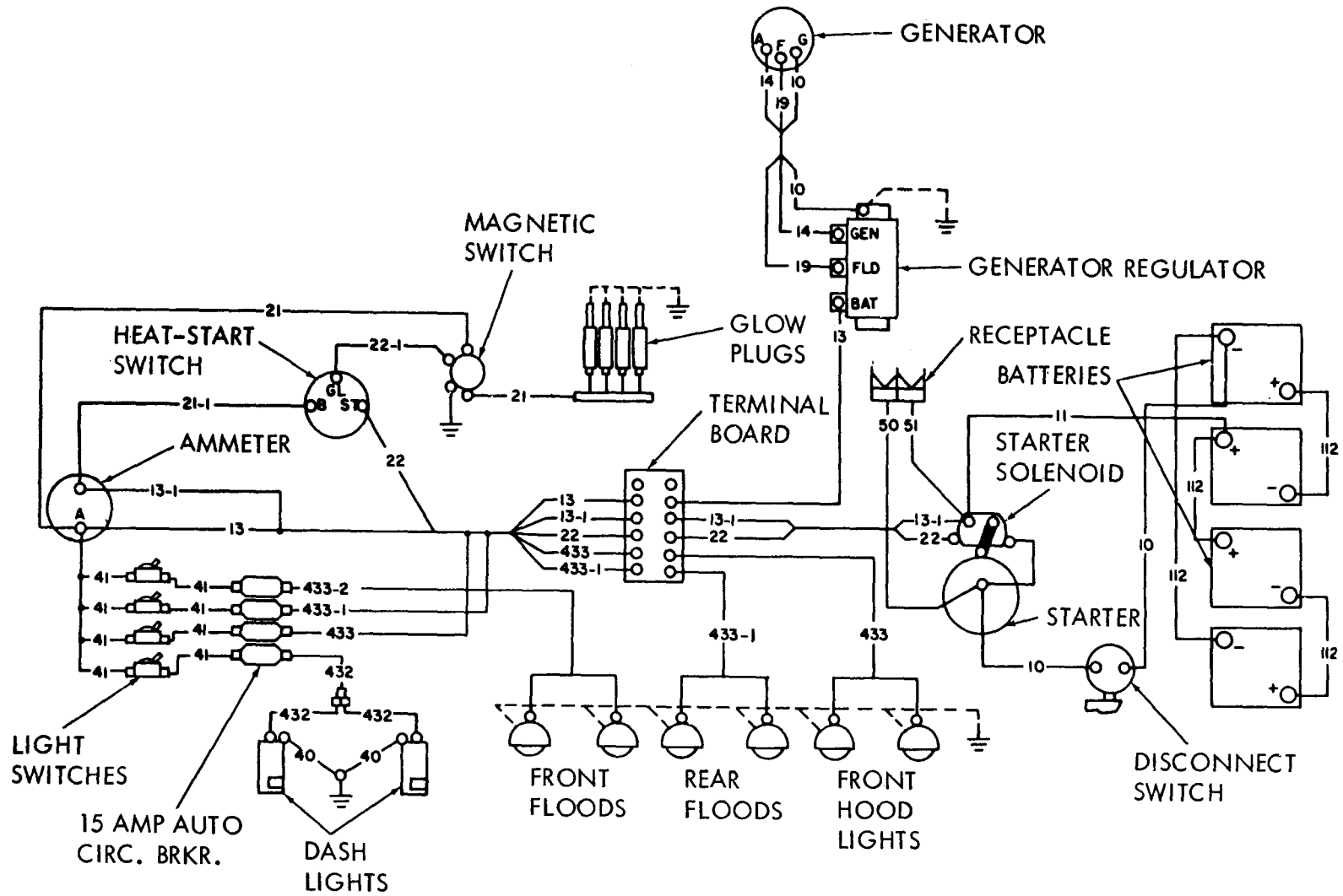
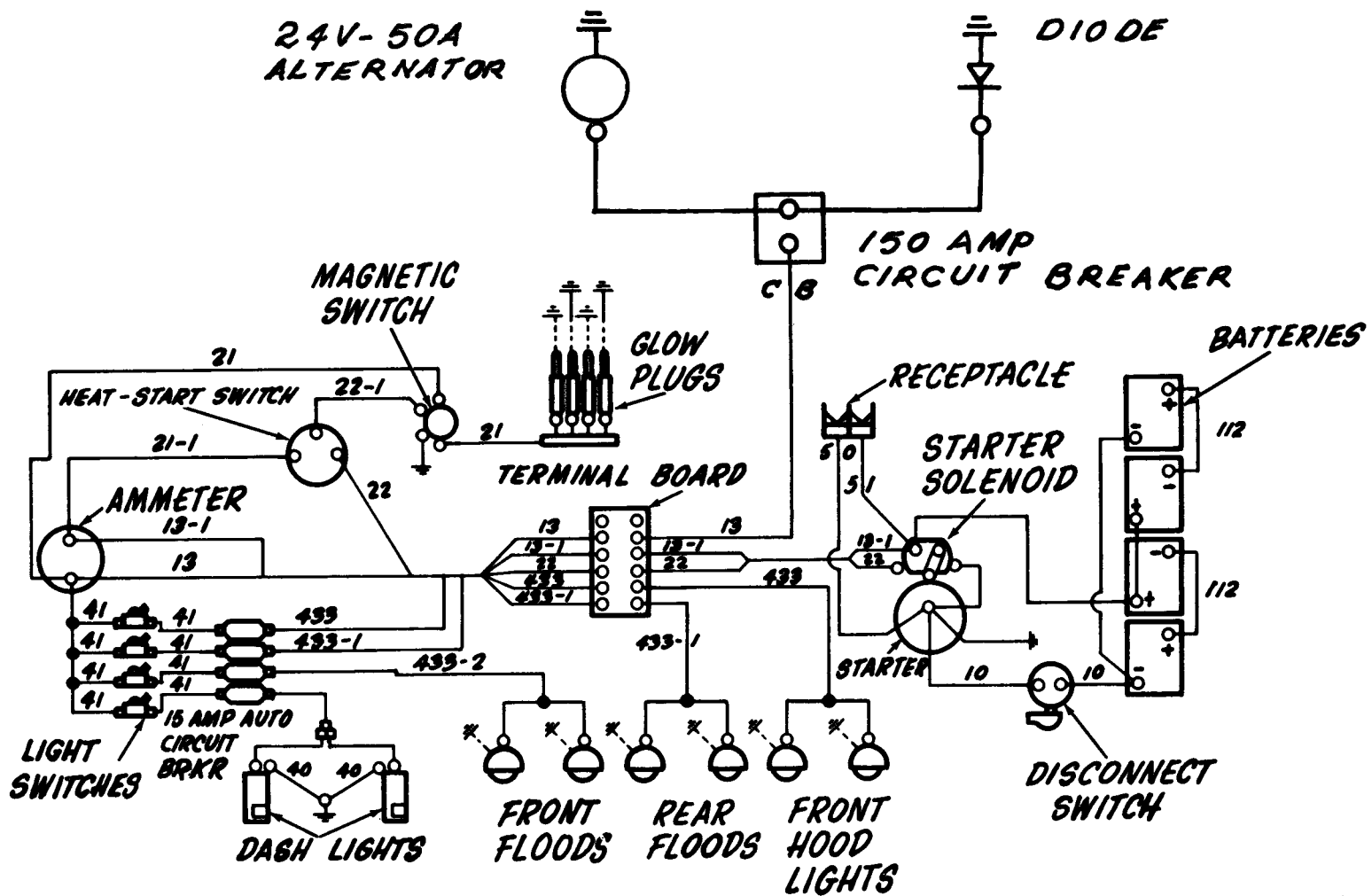

Figure 1-5. Tactor, right front three-quarter view.



TS 003556

Figure 1-6. Electrical System schematic diagram (generator) (sheet 1 of 2) (Serial Nos. 75E1 through 75E1300).



TS 003557

Figure 1-6. Electrical System schematic diagram (alternator) (sheet 2 of 2).

## CHAPTER 2

### OPERATING INSTRUCTIONS

---

#### **WARNING**

If equipment fails to operate, refer to troubleshooting procedures in Chapter 3.

#### **Section I. OPERATING PROCEDURES**

#### **WARNING**

Make sure the Roll Over Protection Structure is properly secured and not damaged, and that the seat belt is used by the operator.

Failure to observe the above conditions can result in serious injury or death to the operator personnel.

#### **2-1. General**

This section describes the various controls and instruments and provides the operator/crew sufficient information to insure proper operation of the tractor.

#### **2-2. Controls and Instrument**

The controls and instruments and the normal readings of the instruments are illustrated in figure 2-1.

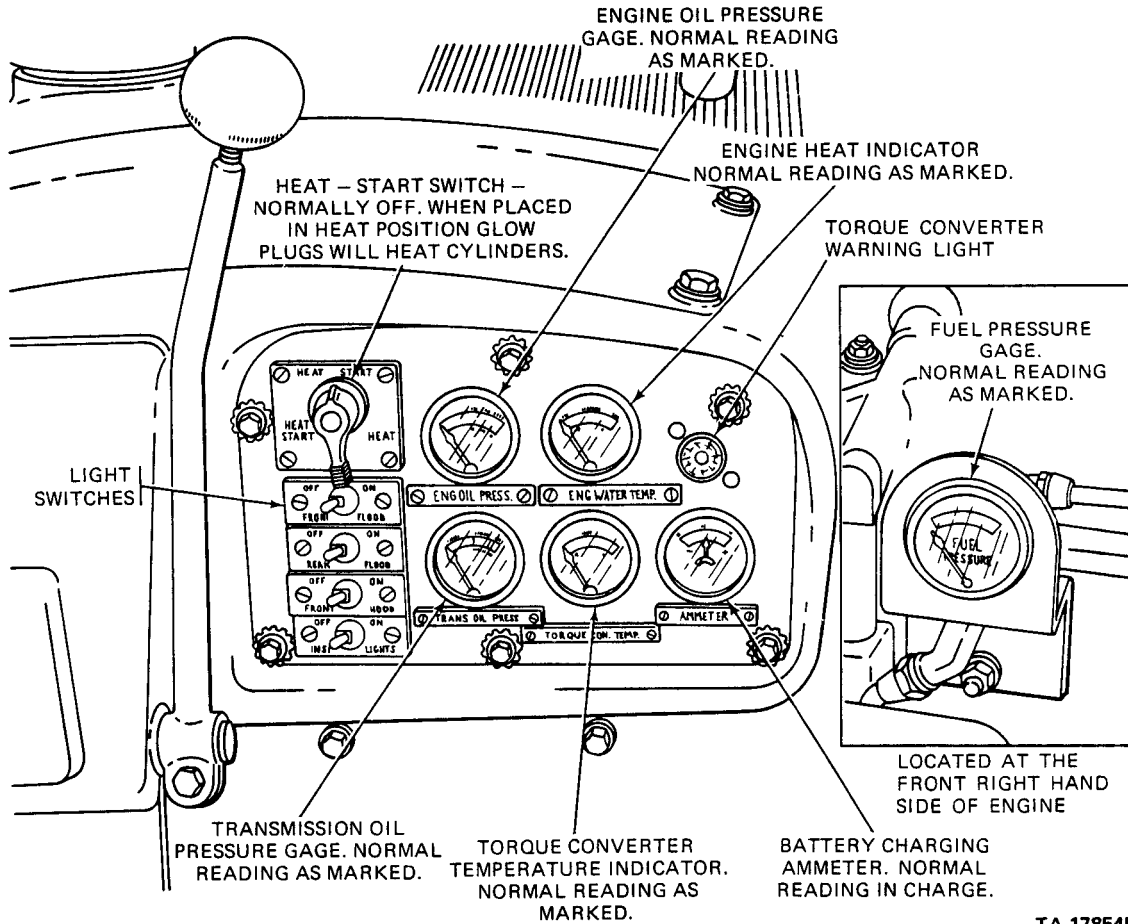

TA 178545

Figure 2-1. Controls and instruments (sheet 1 of 6) (Serial Nos. 75E1 through 75E1300).



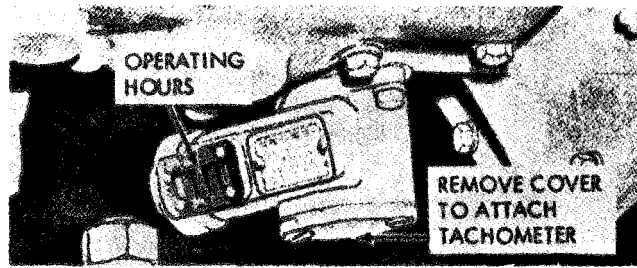

Figure 2-1. Controls and instruments (sheet 2 of 6) (Serial Nos. 715E1301 and up).

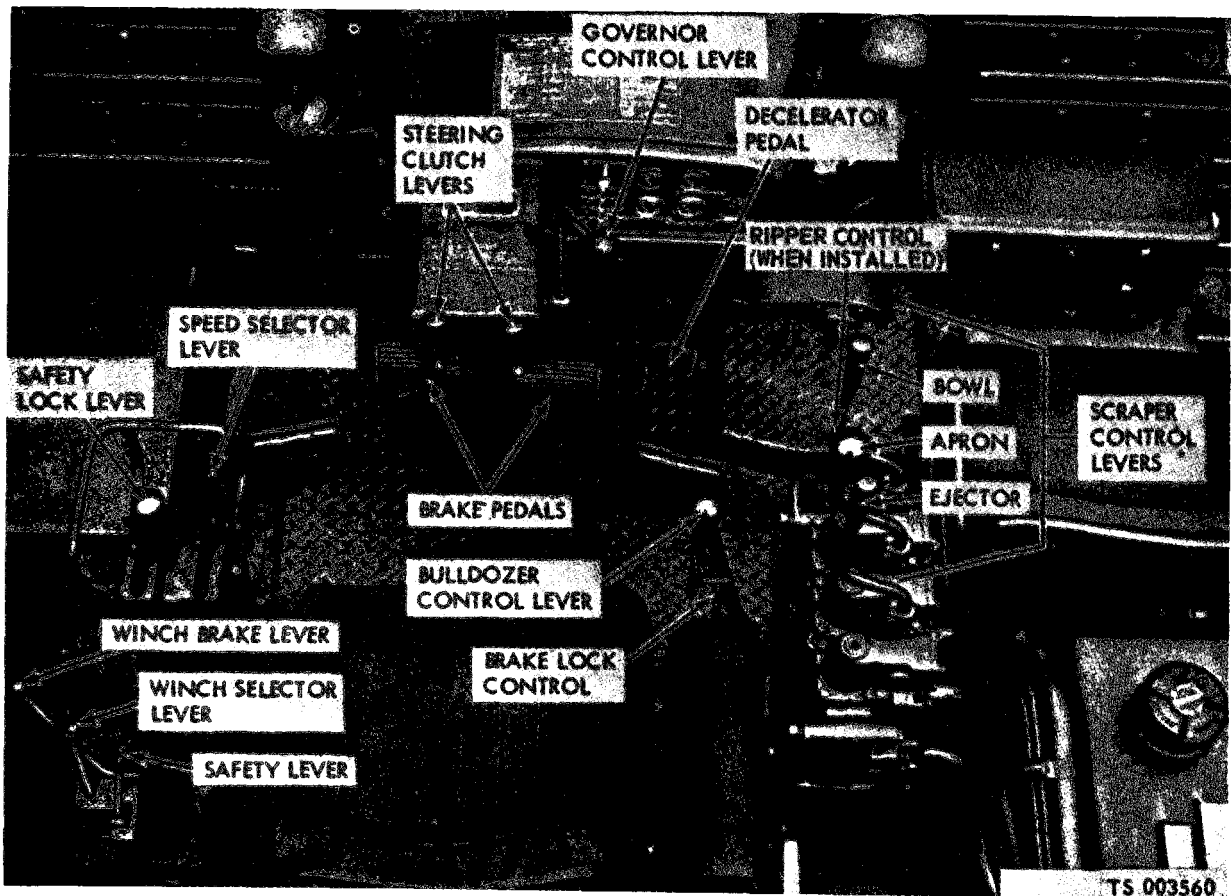
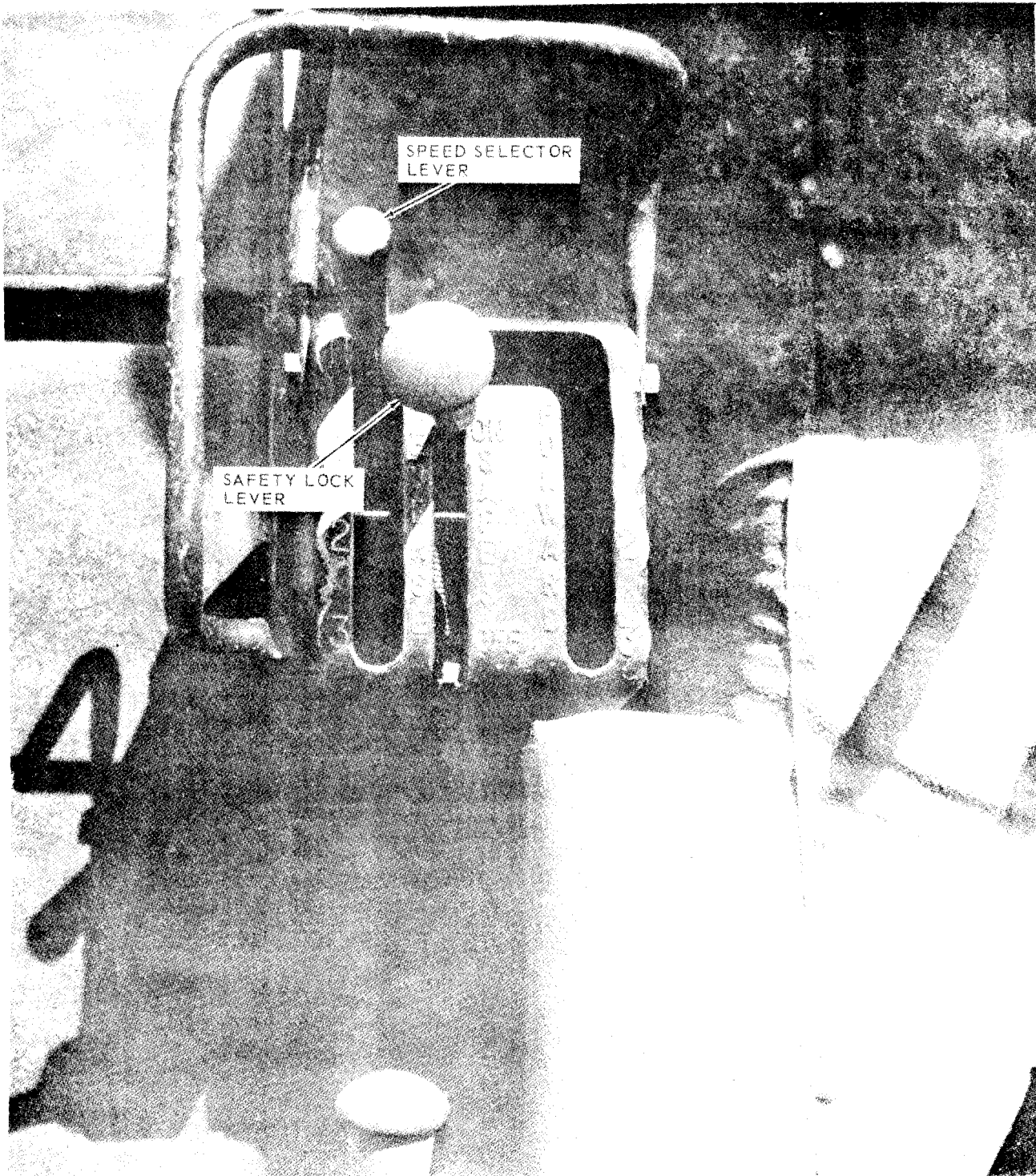

Figure 2-1. Control and instruments (sheet 3 of 6).



TS 003561

Figure 2-1. Controls and instruments (sheet 4 of 6). (Serial Nos. 75E1 and up).

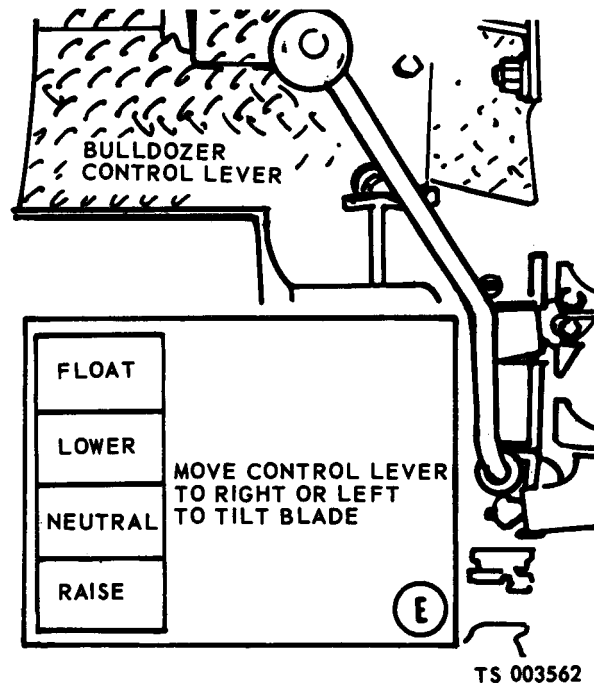

Figure 2-1. Controls and instruments (sheet 5 of 6).

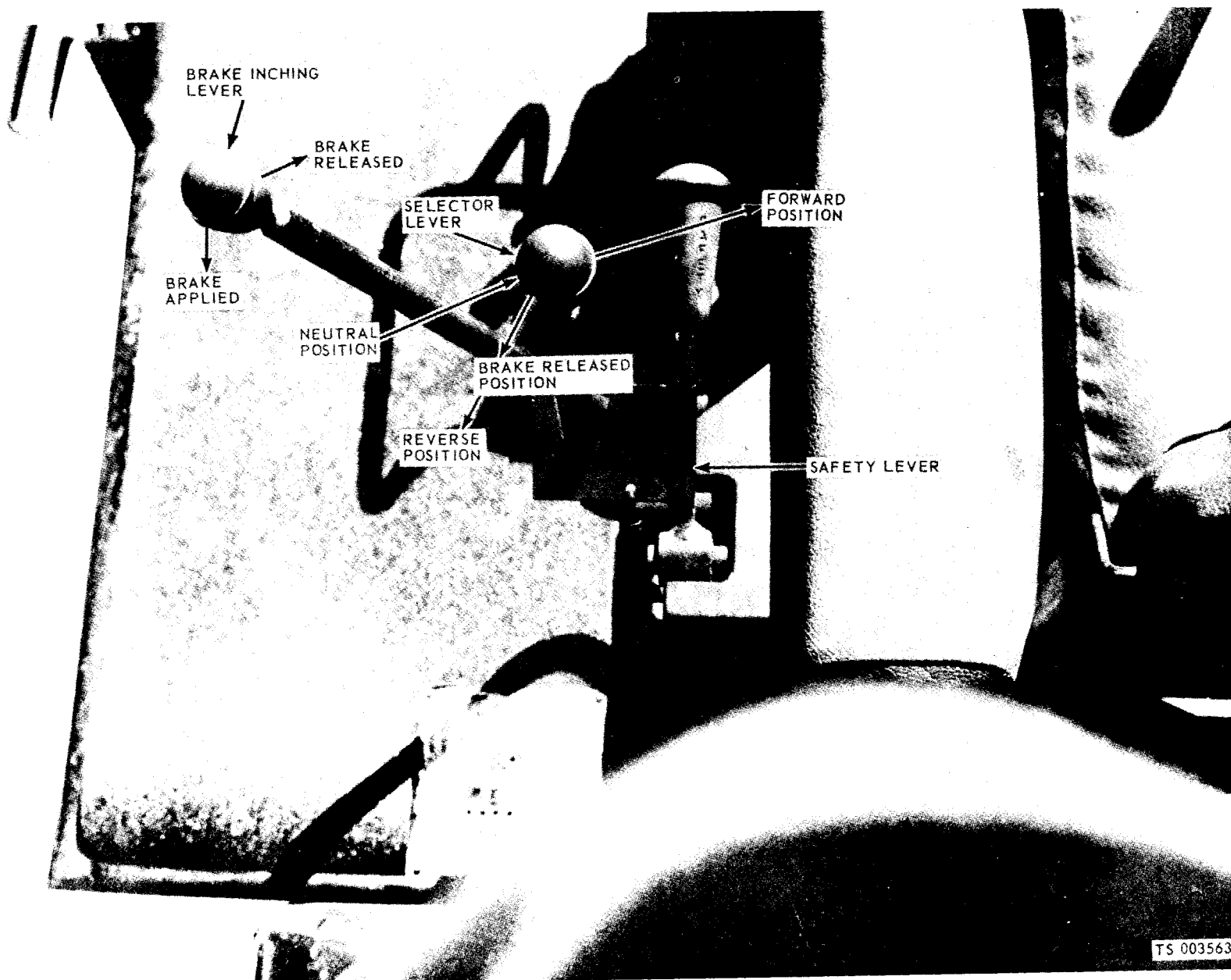

Figure 2-1. Controls and instruments. (sheet 6 of 6).

**2-3. Starting**

a. *Preparation for Starting.* Perform the before-operation checks and services (para 3-1).

b. *Starting.* Refer to figure 2-2 and start the tractor engine with serial numbers 75E1 through 75E1300. For tractors with serial numbers 75E1301 and up, refer to figure 2-2 (A and B) and proceed as follows:

(1) Apply brakes and lock with BRAKE LOCK CONTROL.

(2) Lock SPEED SELECTOR LEVER in neutral with SAFETY LOCK.

(3) Turn DISCONNECT SWITCH ON (located on left side of operator's seat frame).

(4) Pull GOVERNOR CONTROL LEVER back until it snaps over detents to open fuel injection pumps.

(5) Turn HEAT-START SWITCH to HEAT position for time indicated below.

Glow Plug Heating Time	
Starting temperature range	HEAT - START SWITCH ON HEAT
Above 60 F.	None
60 F. to 32 F.	1 minute
Below 32 F.	2 minutes

(6) Turn HEAT-START SWITCH to START position.

**CAUTION**

**Never operate electric starter more than 30 seconds at a time. Allow 2 minutes for cooling before using starter gain.**

(7) When engine starts, return HEAT-START SWITCH to HEAT position (when temperature is below 60 F.) until engine runs smoothly. If engine does not start after 10 seconds, turn HEAT-START SWITCH to HEAT position for 30 seconds then repeat starting procedure.

**CAUTION**

**Do not turn HEAT-START SWITCH to HEAT position while engine is warm and running. Never turn DISCONNECT SWITCH off when engine is running; damage to generator, regulator, and lights may result. When engine is stopped, turn DISCONNECT SWITCH off to prevent battery discharge. Run engine at low rpm during initial start to allow lubrication oil to reach turbocharger.**

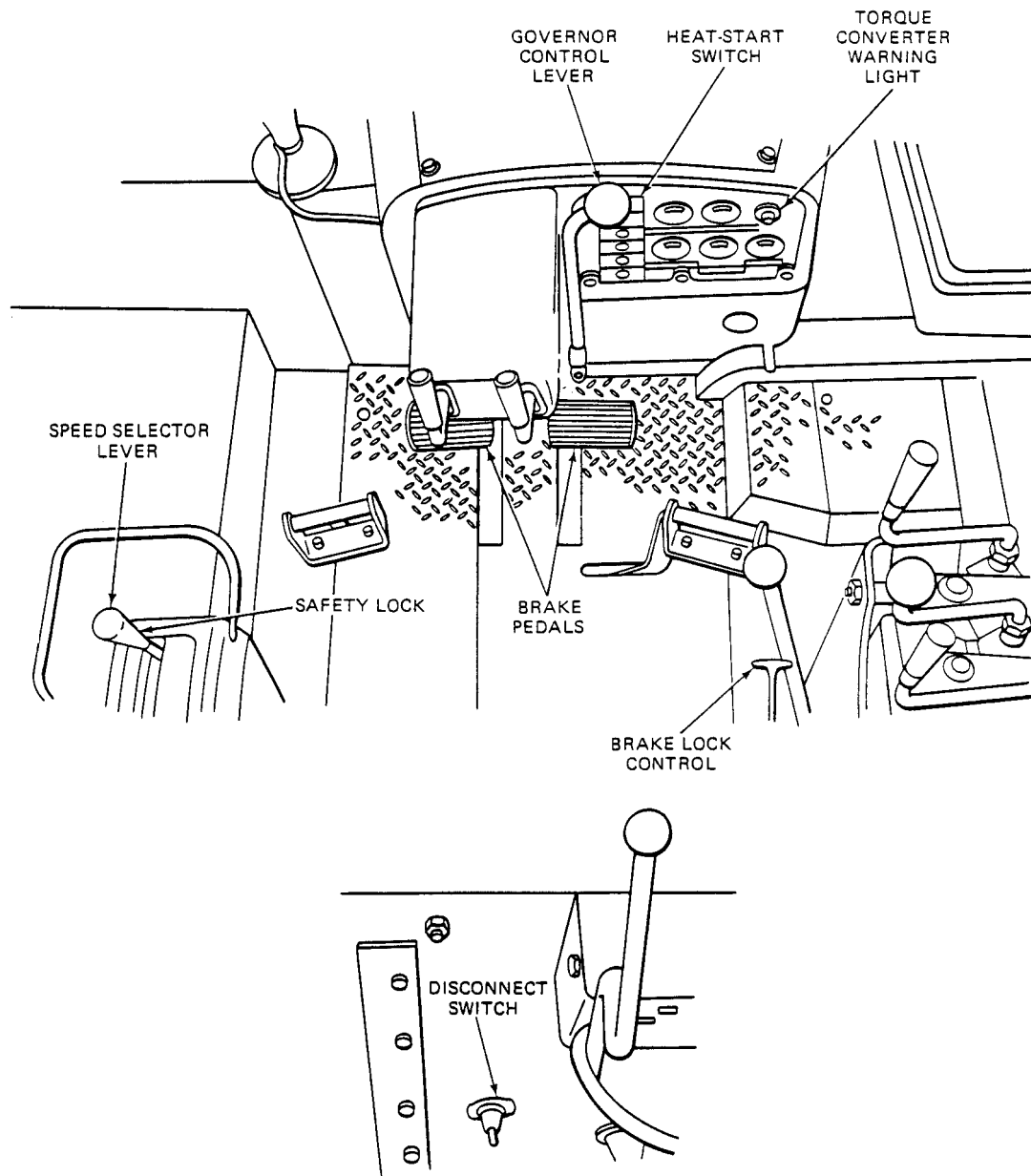

TA 178544

Figure 2-2. Starting the tractor engine (Serial Nos. 75E1 through 75E1300 ).

## 2-4. Operation of Equipment

### a. Tractor Operation.

(1) Operate the tractor (fig. 2-3).

(2) *Transmission shifting.* Shifting speeds or directions is permissible at any speed and under any load condition, although normally the decelerator will be depressed to reduce engine speed when making a directional change.

#### CAUTION

Place safety lock lever in ON position when tractor is allowed to stand with engine running. The safety lock prevents accidental engagement of the transmission.

(3) *Extreme tilt operation.* When operating under extreme conditions of tilt, transmission oil pressure may drop due to insufficient oil at pump inlet. A drop in oil pressure will cause transmission to shift to neutral. Under such conditions, it is permissible to add oil above the "full" mark up to 10 percent of capacity. Reduce oil level when tractor is again operated under normal conditions.

(4) *Operating down grade.* When going down grade with tractor pulling load, steer in usual manner. If load is pushing tractor, operation of steering clutches is reversed. For example, to turn to right under these conditions

release steering clutch on left, but do not apply brake. This allows left track to travel faster while right track is held back by engine which acts as a brake.

(5) *Operating over an obstruction.* When running over an obstruction, such as a log or a ditch bank, both clutches may be released slightly until tractor balances on top of obstruction. One clutch may be engaged gradually so that tractor moves forward at an angle, over and down. If tractor is being operated without a load it may be necessary to use brakes.

*b. Bulldozer Operation.*

(1) Refer to figure 2-1(7) and operate bulldozer as follows:

(a) To raise moldboard, pull lever back.

(b) To lower moldboard, push lever forward.

(c) To hold moldboard in position, allow lever to spring back to center.

(d) To allow moldboard to float, push lever all the way forward past the lower position.

(e) To tilt moldboard to left, move lever to left.

(f) To tilt moldboard to right, move lever to right.

(g) To change digging angle of moldboard, adjust length of tilt brace.

**NOTE**

**When the hydraulic pistons have reached the limit of their stroke, either raised or lowered, release the control lever to stop the oil by-passing the valves, and also to reduce heat and wear.**

(2) When bulldozing, a trench usually is formed from material spilled on each side of the moldboard. If possible, work tractor within the trench for maximum possible loads.

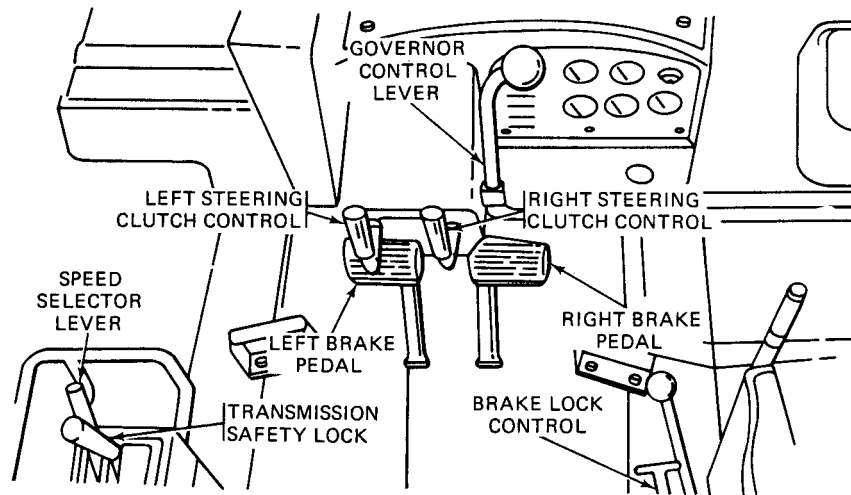

THE DIRECTION OF TRAVEL OF THE TRACTOR IS CONTROLLED BY TWO STEERING CLUTCH LEVERS. A HYDRAULIC BOOSTER SYSTEM ACTUATES THE STEERING CLUTCHES WITH A MINIMUM OF PHYSICAL EFFORT BY THE OPERATOR.

TO MAKE A SHARP TURN OR PIVOT, USE THE STEERING BRAKE ON THE SIDE TOWARD WHICH THE TURN IS TO BE MADE.

TO TURN TO THE RIGHT OR LEFT, PULL BACK THE STEERING CLUTCH LEVER ON THE SIDE TOWARD WHICH THE TURN IS TO BE MADE.

TO TURN LEFT  
PULL BACK ON  
LEFT-HAND  
STEERING  
CLUTCH  
LEVER

TO TURN RIGHT  
PULL BACK ON  
RIGHT-HAND  
STEERING  
CLUTCH LEVER

TO MAKE A SHARP TURN OR PIVOT, USE THE STEERING BRAKE ON THE SIDE TOWARD WHICH THE TURN IS TO BE MADE.

<p>SHARP TURN LEFT:</p> <ol style="list-style-type: none"> <li>1. PULL BACK ON LEFT-HAND STEERING CLUTCH LEVER</li> <li>2. PUSH DOWN ON LEFT STEERING BRAKE PEDAL</li> </ol>	<p>SHARP TURN RIGHT:</p> <ol style="list-style-type: none"> <li>1. PULL BACK ON RIGHT-HAND STEERING CLUTCH LEVER</li> <li>2. PUSH DOWN ON RIGHT STEERING BRAKE PEDAL</li> </ol>
--	---

WHENEVER PULLING BACK ON THE STEERING CLUTCH LEVER DOES NOT TURN THE TRACTOR SHARPLY, ENOUGH, PRESS DOWN GENTLY ON THE STEERING BRAKE PEDAL UNTIL THE DESIRED TURN IS MADE.

IMPROPER USE OF THE STEERING BRAKES WHEN MAKING TURNS WILL CAUSE THE TRACTOR TO JERK. AVOID THIS BY USING THE STEERING CONTROL INTERMITTENTLY WITH ONLY A SLIGHT PRESSURE ON THE BRAKE PEDAL WHEN MAKING ANY TURN EXCEPT A PIVOT TURN. THIS GIVES A SMOOTHER TURN AND DOESN'T SUBJECT THE TRACTOR TO SUDDEN IMPACTS.

DON'T RIDE THE BRAKE PEDALS. THAT WILL RESULT IN EXCESSIVE WEAR ON BRAKE LININGS.

**NOTE**

**NOTE**

STEERING BRAKES SHOULD NEVER BE APPLIED UNLESS STEERING CLUTCHES ARE COMPLETELY DISENGAGED.

WHEN PULLING A LOAD, IT IS NOT NECESSARY TO USE THE BRAKES EXCEPT TO MAKE VERY SHARP TURNS OR TO PIVOT; THE LOAD ACTS AS A BRAKE. DO NOT USE THE BRAKES UNLESS IT IS NECESSARY TO DO SO TO MAKE THE REQUIRED TURN.

TA 178531

Figure 2-3. Steering the tractor (sheet 1 of 2).



- STEP 1. START TRACTOR ENGINE (PARA 2-3).
- STEP 2. BEFORE APPLYING LOAD, ALLOW ENGINE TO WARM BY RUNNING ENGINE FIVE MINUTES WITH GOVERNOR CONTROL LEVER IN HALF SPEED POSITION.
- STEP 3. MOVE GOVERNOR CONTROL LEVER TO DESIRED POSITION.
- STEP 4. DISENGAGE BRAKE LOCK BY DEPRESSING BOTH BRAKE PEDALS - THIS ALLOWS BRAKE LOCK TO RELEASE.
- STEP 5. RAISE ALL LOWERED EQUIPMENT PRIOR TO MOVING SAFETY LOCK CONTROL LEVER.
- STEP 6. MOVE SAFETY LOCK CONTROL LEVER TO OFF POSITION - THEN MOVE SPEED SELECTOR LEVER TO DESIRED DIRECTION AND SPEED.
- STEP 7. THE DIRECTION OF TRAVEL OF THE TRACTOR IS CONTROLLED BY TWO STEERING CLUTCH LEVERS . A HYDRAULIC BOOSTER SYSTEM ACTUATES THE STEERING CLUTCHES WITH A MINIMUM OF PHYSICAL EFFORT BY THE OPERATOR.
- (A) TO TURN TO THE RIGHT OR LEFT, PULL BACK THE STEERING CLUTCH LEVER ON THE SIDE TOWARD WHICH THE TURN IS TO BE MADE. (FIG 2-3).
- (B) TO MAKE A SHARP TURN OR PIVOT, USE THE STEERING BRAKE ON THE SIDE TOWARD WHICH THE TURN IS TO BE MADE. FOR EXAMPLE: TO TURN SHARPLY TO THE RIGHT, PULL BACK ON THE RIGHT STEERING CLUTCH LEVER AND THEN PUSH DOWN ON THE RIGHT STEERING BRAKE PEDAL.
- (C) IF PULLING BACK ON THE STEERING CLUTCH LEVER DOES NOT TURN THE TRACTOR ENOUGH, PRESS DOWN GENTLY ON THE STEERING BRAKE PEDAL UNTIL THE DESIRED TURN IS MADE.
- DO NOT RIDE THE BRAKE PEDALS AS THIS WILL RESULT IN EXCESSIVE WEAR ON THE BRAKE LININGS. STEERING BRAKES SHOULD NEVER BE APPLIED UNLESS STEERING CLUTCHES ARE COMPLETELY DISENGAGED. IMPROPER USE OF THE STEERING BRAKES WHEN MAKING TURNS WILL CAUSE THE TRACTOR TO JERK. AVOID THIS BY USING THE STEERING CONTROL INTERMITTENTLY WITH ONLY A SLIGHT PRESSURE ON THE BRAKE PEDAL WHEN MAKING ANY TURN EXCEPT A PIVOT TURN. THIS METHOD OF TURNING GIVES A MORE EVEN TURN AND DOES NOT SUBJECT THE TRACTOR TO SUDDEN IMPACTS .
- WHEN PULLING A LOAD, IT IS NOT NECESSARY TO USE THE STEERING BRAKES EXCEPT TO MAKE SHARP TURNS; THE LOAD ACTS AS A BRAKE. DO NOT USE THE BRAKES UNLESS IT IS NECESSARY TO DO SO TO MAKE THE REQUIRED TURN.
- STEP 8. USE DECELERATOR TO REDUCE ENGINE SPEED WITHOUT DISTURBING THE GOVERNOR CONTROL LEVER POSITION.

*Figure 2-3. Steering the tractor (sheet 2 of 2).*

(3) When removing brush and small trees, lower cutting edge into ground enough to strike and cut roots.

(4) When removing heavier trees, raise moldboard to a higher position to gain leverage and push tree to ground. Lower moldboard to ground and cut roots.

(5) Moldboard adjustment.

(a) Digging angle of moldboard can be increased or decreased by adjusting length of tilt brace and activating hydraulic tilt cylinder to move left side of moldboard a corresponding distance.

(b) To lengthen tilt brace, turn adjusting bar (fig. 1-1) clockwise (when viewed from rear). To shorten tilt brace turn adjusting bar counterclockwise. After adjustment, lock tilt brace by inserting end of adjusting bar into locking slot at rear of moldboard.

#### NOTE

The bulldozer should never be operated with more than 1/2 inch of the threads on the tilting brace screw exposed.

(6) Removing rock and boulders.

(a) Tilt the bulldozer.

(b) Place a corner of moldboard under rock and work it up and down while pushing on rock.

(c) Disengage the steering clutch opposite the point of moldboard under the rock. This will aid in preventing tractor from stalling.

(7) Finishing.

(a) Adjust moldboard to desired position.

(b) To level surface, reverse tractor and drag moldboard.

#### c. Scarifying.

(1) Raise and adjust moldboard to desired position.

(2) Position the four scarifiers to lower mounting holes on back of moldboard and install hinge pins and lock pins.

(3) Lower moldboard to surface, with scarifiers swinging into a digging position when tractor is operated in a reverse speed. The scarifiers trail moldboard when tractor is in forward motion.

#### d. Scapr Operation.

(1) Manifold connections. A manifold is mounted at the rear of the tractor to provide connections between tractor hydraulic system and scraper hydraulic lines.

(2) Bowl control lever (fig. 2-1(4)). Control levers are mounted to right of operator's seat.

(a) Raise position is obtained by pulling bowl control lever toward operator. Release lever as hydraulic cylinder rods approach the end of the stroke.

(b) Hold position will hold bowl in desired position when bowl control lever is released.

(c) Lower position is obtained by pushing bowl control lever away from operator. Pushing control lever through lower position will allow the quick drop valve to open and drop bowl-faster for pump loading. Release control lever when cylinder rods have reached limit of their strokes to stop oil from bypassing valves and also reduce heat and wear.

(3) Apron control lever.

(a) Raise position is obtained by pulling apron control lever toward operator. Release lever as hydraulic cylinder rod approaches end of stroke.

(b) Hold position will hold apron in desired position when apron control lever is released.

(c) Lower position is obtained by pushing apron control lever away from operator.

(d) Float position is obtained by pushing apron control lever through lower position where it will remain-until lever is pulled to lower position.

(4) Ejector control lever.  
(a) Forward position  
is obtained by pulling ejector  
control lever toward operator.

Release lever as hydraulic cylinder  
rod approaches end of stroke.  
(b) Hold position will hold  
ejector in

desired position when ejector control lever is released.

(c) Return position is obtained by pushing ejector control lever away from operator.

(d) Lockout position is obtained by pushing ejector control lever through return position where hydraulic oil pressure holds control lever in lockout position. When control lever is in lockout position, operator can release it and continued return of ejector to rear position can be realized. When ejector is fully returned, or apron control lever or bowl control lever is actuated, hydraulic oil pressure is reduced and ejector control lever returns to hold position.

*e. Winch Operation.*

(1) Refer to figures 2-1(5) and 2-1(6) and operate the winch as follows:

(a) For normal operation, only the SELECTOR LEVER is used; push for reverse and pull for forward.

(b) Brake is automatically released "when a clutch is engaged and applied when SELECTOR LEVER is in NEUTRAL position.

(c) SELECTOR LEVER has fourth a position; BRAKE OFF.

(d) For inching a load, pull on BRAKE LEVER; it will automatically return to the applied position when released.

(e) Vary line speed by throttling engine.

(f) Low idle is recommended for reverse.

(g) SELECTOR LEVER must be in NEUTRAL for gradual brake-off.

(h) Ease SELECTOR LEVER into NEUTRAL to hold a tight line.

NOTE

When winching, keep the cable in line with the longitudinal axis of the tractor as much as possible. Do not directly winch any objects at angles greater than 5° to either side.

*f. Ripper Operation.*

(1) *Manifold connections.* A manifold is mounted at rear of the tractor to provide connections between the tractor hydraulic system and ripper hydraulic cylinders.

(2) *Ripper control lever.* The apron control lever is used to operate the ripper. Refer to figure 2-4 and proceed as follows to operate ripper:

(a) Placing CONTROL LEVER in RAISE position will raise ripper. Release lever as the hydraulic cylinder rod (fig. 1-1 ) approaches the end of stroke.

(b) HOLD position will hold ripper in

desired position when CONTROL LEVER is released.

(c) Place CONTROL LEVER in LOWER position to lower ripper.

(3) For ripping packed soils, hardpan, clays, shales, proceed as follows:

(a) Use all three ripper shanks.

(b) Pull ripper straight into material, shift to first gear, and lower ripper gradually as tractor moves forward. Lower ripper to full depth and release control to HOLD position. It may be necessary to raise and lower ripper to keep tractor from stalling and properly break up material.

(c) Do not bulldoze ripped material before ripping deeper. Keep several inches of ripped material above the unripped formation to cushion tractor and provide traction.

CAUTION

Do not turn the tractor abruptly or reverse direction while the shanks are in the ground. This puts a twisting strain on the shanks and tips which could result in serious damage to the ripper.

(4) *Ripping stratified or liminated rock.*

(a) Use the two outside ripper shanks.

NOTE

If the tractor begins to spin or stall, or hang up on hard spots, use only the center shank.

(b) Pull ripper straight into material, shift to first gear, and lower ripper gradually as tractor moves forward. Control ripper depth so tractor will not stall and material will break up properly.

(c) Refer to step 3c and Caution above.

(5) *Ripping asphalt road surfaces.*

(a) Use the two outside ripper shanks.

(b) Pull ripper straight into material, shift to first gear, and lower ripper gradually as tractor moves forward. Smooth asphalt surface may affect good traction. Raise and lower ripper accordingly to break material properly. Observe Caution instructions in step 3 above.

(6) *Concrete road surfaces.*

(a) Use only the center ripper shank.

(b) Pull ripper straight into material, shift into first gear, and lower ripper gradually as tractor moves forward. Control ripper depth so tractor will not stall and material is broken up properly. As reinforcing rods or wire is severed, concrete will break into smaller pieces thus making it easier to handle.

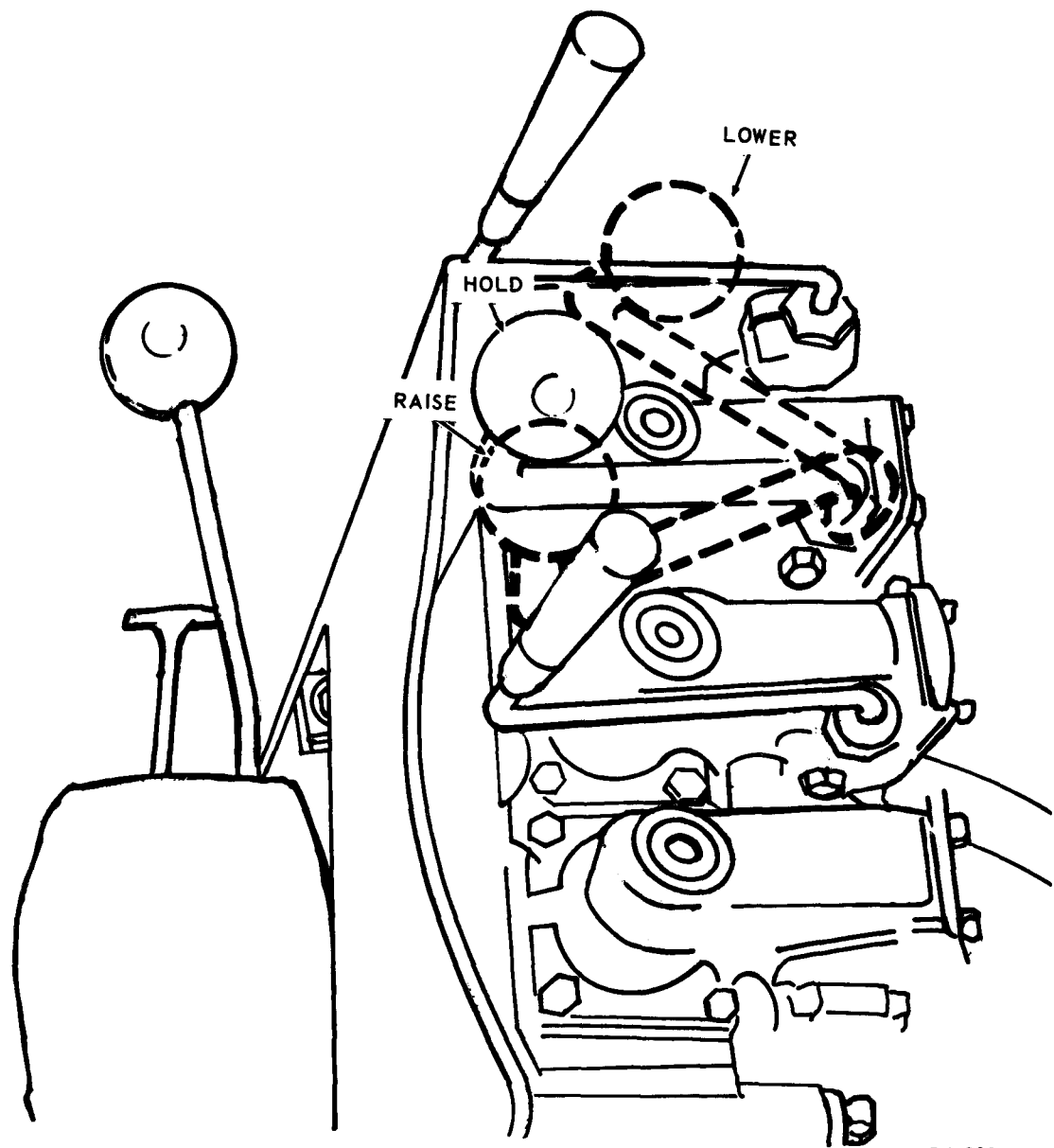

TS 003566

Figure 2-4. Ripper control lever positions.

*g. Ripper Adjustment.*

(1) **Two ripping depth adjustments are available. Maximum penetration is approximately 25 inches with the shanks in their lowest position. Placing shanks in their highest position will result in about 15 inches penetration. The job layout will determine shank placement.**

(2) Refer to figure 2-5 and proceed as follows to adjust the ripper.

(a) **Attach a suitable lifting device to shank eye.**

(b) **Remove cotter pin, retainer, and pin.**

(c) **Raise or lower shank to desired position.**

**NOTE**

Shank shown in its highest position (15 inch penetration).

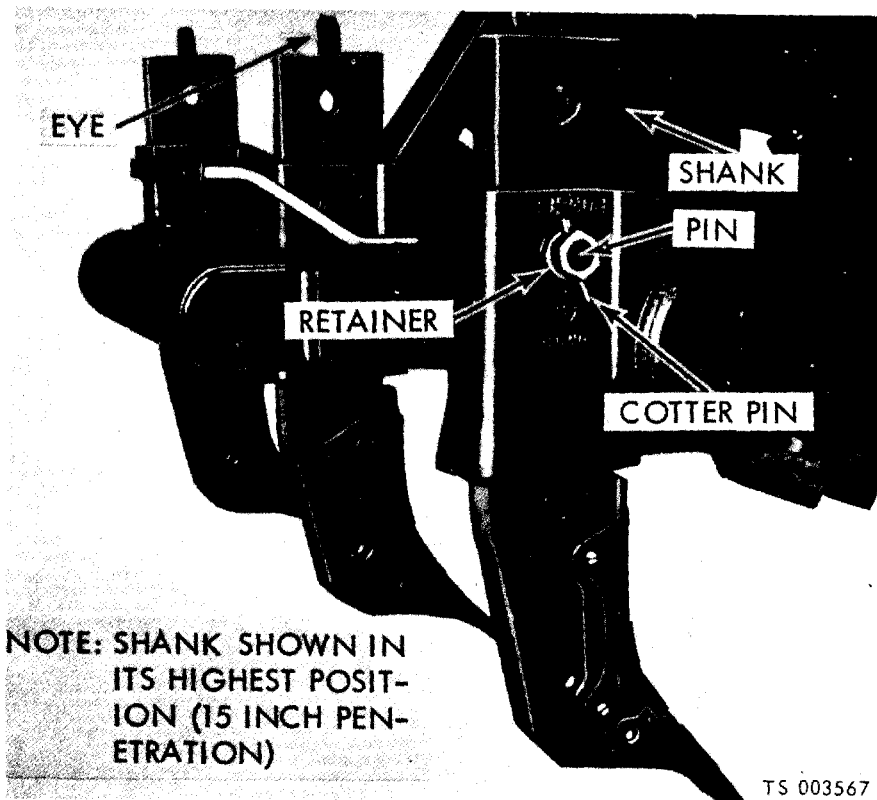

Figure 2-5. Ripper shank adjustment.

**2-5. Stopping the Tractor**

Refer to figure 2-2 and stop the tractor engine.

- STEP A. MOVE SPEED SELETOR LEVER TO NEUTRAL AND SAFETY LOCK TO ON
- STEP B. APPLY BRAKES AND LOCK WITH BRAKE LOCK CONTROL
- STEP C. ALLOW ENGINE TO IDLE FOR 5 MINUTES WITH GOVERNOR CONTROL LEVER AT HALF SPEED POSITION
- STEP D. REDUCE ENGINE SPEED TO LOW IDLE AND ALLOW ENGINE TO RUN FOR 30 SECONDS
- STEP E. STOPENGINE BY MOVING GOVERNOR CONTROL LEVER TO SHUT-OFF POSITION
- STEP F. TURN DISCONNECT SWITCH TO OFF POSITION

**Section II. OPERATION UNDER UNUSUAL CONDITIONS**

**2-6. Operation m Extreme Cold**

a. *General* In extreme cold temperatures, make all necessary preparations to prevent damage to the tractor. Always allow the engine to warm slowly. Apply all controls carefully so that none are forced.

b. *Starting the Engine.*

(1) Prepare engine for starting (para 2-10).

(2) Allow engine to operate at approximately 1/2 throttle for 10 or 15 minutes to allow oil in torque converter and transmission hydraulic system to circulate before applying load to the system.

**NOTE**

Leave transmission range selector lever in neutral position and both steering levers in their neutral position during warmup period.

c. *Cooling System.* Before draining and refilling the cooling system with antifreeze, inspect the system for leaks and general condition. Replace all damaged hoses. Check clamps for tightness and see that drain cocks are properly closed. When adding antifreeze to the system drain sufficient coolant to compensate for the added volume of antifreeze. Operate the engine

for 15 minutes after operating temperature is reached, to mix solution.

**NOTE**

**If antifreeze is not available, drain the cooling system after operation ceases. If tractor is to be used again, again, close drain drain cock and fill and fill cooling system.**

*d. Lubrication.* Use the correct grade of lubricants for all points of application. Drain and refill where necessary if grade of lubricant is not correct for cold weather operation.

*e. Fuel System.* Precautions must be taken to eliminate water and moisture from the fuel system. Make sure all fuel filter elements are clean. Drain off any water from fuel tank at the end of each day's operation. To avoid condensation, completely fill the fuel tank after each operating period. Do not allow the tank to remain partially empty over long periods of time. Thoroughly clean all ice and snow from filler opening before refilling.

*f. Batteries.* Keep batteries fully charged. Cranking power of batteries is reduced during extreme cold.

*g. At Halt or Parking.*

(1) Park tractor in a sheltered place if possible. Cover to protect engine, accessories, and controls from ice and snow.

(2) If possible, run tractor onto planks to prevent tracks from freezing to the ground. Block up bulldozer.

**CAUTION**

**If mud or snow collects on tracks during operating period and is allowed to freeze solid while tractor is idle, or if tracks freeze solidly to the ground, apply heat to loosen frozen material or tracks. Serious damage will be caused by an attempt to break tractor loose under engine power, or by moving tractor with large frozen lumps of material in tracks.**

**2-7. Operation in Extreme Heat**

*a. General.* The cooling and lubricating system should be carefully watched.

*b. Cooling.* Keep a watch on the coolant. Remove all obstructions and foreign material collected on the radiator fins and air passages. Use only clean water or approved coolant mixture in radiator.

*c. Lubrication.* Make sure all breathers are open and free of dirt. Use correct grade lubricants as specified in the lubrication order.

*d. Fuel System.* Make sure all filters and elements are clean. Drain off condensate from fuel tank daily. Keep fuel tank full at all times.

**2-8. Operation in Dusty or Sandy Areas**

*a. General.* Sand and dust are abrasive and cause wear on many parts of the tractor.

*b. Cooling.* Inspect the cooling system often for loss of fluid, clogged radiator, or leaks. Flush the cooling system frequently.

*c. Lubrication.* Refer to the lubrication chart for proper lubricant. Clean all fittings and change filter frequently.

*d. Fuel System.* Inspect frequently for leaks. Clean dirt and drain water from filter.

**2-9. Operation in Deep Mud or Water**

*u.* If the tractor must be operated for any length of time in deep mud or water, certain precautions are necessary.

*b.* Inspect the oil in the final drives frequently for mud or water. Drain, wash, and refill if the oil shows the presence of any mud or water.

*c.* Presence of mud in the final drives or excessive leakage of oil indicates need of repair or seal replacement.

**2-10. Operation Under Rainy or Humid Conditions**

*a. General.* High humidity conditions generally do not affect the operation of the tractor.

*b. Fuel System.* Keep fuel tank full at all times if possible.

*c. Lubrication.* Keep all friction moving parts well lubricated.

**2-11. Operation in Salt Water Areas**

*a. General.* In salt water areas, keep the tractor as clean as possible. Salt water cause corrosion of exposed parts. After operation is complete, wash with fresh water, if available.

*b. Lubrication.* Keep all lubricating points well lubricated.

**2-12. Operation at High Altitudes**

*a.* The maximum turbocharger speed is determined by the fuel rack setting, the high idle speed, the turbine nozzle and the altitude. The rack and high idle speed settings have been established to permit the engine to be operated at the altitude marked on the warning plate on the dash.

**WARNING**

**Serious injury to personnel or damage to the equipment may result from turbocharger overspeeding if engine is operated at an altitude higher than marked on the warning plate. If engine must be operated at a higher altitude,**

refer to direct support maintenance personnel for proper adjustment.

*b.* The engine can be operated at lower

altitudes without changing the adjustments, but with slightly less than maximum performance.



## CHAPTER 3

### OPERATOR/CREW MAINTENANCE INSTRUCTIONS

#### Section I. LUBRICATION INSTRUCTIONS

The operator/crew is responsible for checking the level and replenishing engine oil and hydraulic fluid when their level is low. Refer to the current

lubrication orders, LO 5-2410-214 -12-1 and LO 5-2410-214-12-2, for the proper lubrication of the tractor.

#### Section II. PREVENTIVE MAINTENANCE CHECKS AND SERVICES

##### 3-1. General

To insure that the Model D-7E Tractor is ready for operation at all times it must be inspected systematically so that defects may be discovered and corrected before they result in serious damage or failure. The necessary preventive maintenance checks and services to be performed are listed and described in table 3-1. The item numbers indicate the sequence of minimum inspection requirements. Defects discovered during operation of the unit will be noted for future

correction to be made as soon as operation has ceased. Stop operation immediately if a deficiency is noted during operation which would damage the equipment if operation were continued. All deficiencies and shortcomings will be recorded together with the corrective action taken on DA Form 2404 at the earliest possible opportunity.

##### 3-2. Preventive Maintenance Checks and Services

*Table 3-1. Operator/Crew Preventive Maintenance Checks and Services*

**B— Before Operation**  
Time required: 1.5

**D— During Operation**  
Time required: 0.7

**A— After Operation**  
Time required:

Interval and Sequence No.			Item to be inspected procedure	Work time (M / H)
B	D	A		
1			Lubricate in accordance with LO 5-2410-214-12.	0.3
2			<b>ENGINE OIL LEVEL</b>	
3			<b>FUEL</b> Check fuel supply. See that fuel tank is full. Use only approved diesel fuel.	0.5
4			<b>RADIATOR</b> Check coolant level. * Check for leaks in core, lines, hoses, and gaskets.	0.2
5	5		<b>FUEL LINES, VALVES</b> Check fuel lines, shut-off valve, and drain valve for possible leaks. Check fuel tank cap to see that the vent is open.	0.5
6			<b>INDICATORS, GAGES, METERS</b> Check for proper operation: Engine temperature gage—within operating range; Ammeter—on the + side of zero; Engine lubricating oil pressure gage—within operating (green) range; Fuel pressure gage—within operating (green) range; Torque converter temperature gage—within operating (green) range; Transmission operating oil pressure gage—within operating (green) range.	0.5
			<b>AIR RESTRICTION INDICATOR</b> Check	0.2

Section III. TROUBLESHOOTING

3-3. General

This section provides information useful in diagnosing and correcting unsatisfactory operation or failure of the D-7 tractor and its components. Malfunctions which may occur are

listed in table 3-2. Each malfunction stated is followed by a list of probable causes of the trouble. The corrective action recommended is described opposite the probable cause.

Table 3-2. Troubleshooting

MALFUNCTION	TEST OR INSPECTION	CORRECTIVE ACTION
<b>1. ENGINE FAILS TO START</b>		
	Step 1. Check to see if there is air in fuel system.	If air is in fuel system, prime fuel system. See (para 3-8).
	Step 2. Check to see if engine is too cold.	If engine is too cold use starting aid. See (para 2-3).
	Step 3. Check for lack of fuel.	If out of fuel see fig. 3-5.
	Step 4. Inspect for clogged fuel filters.	If clogged clean element in primary filter. Replace elements in final filter (para 3-8).
	Step 5. Inspect for clogged injection valves.	If clogged, replace injection valves (para 4-25).
	Step 6. Inspect for worn injection pumps	If injection pumps are worn, replace injection pump (para 4-25).
	Step 7. Inspect for worn transfer pump.	If worn, replace transfer pump (para 4-28).
<b>2. IRREGULAR ENGINE FIRING</b>		
	Step 1. Inspect for clogged fuel filter elements.	If clogged, clean elements in final filter (para 4-31).
	Step 2. Inspect for clogged air cleaner.	If clogged, service air cleaner (para 3-4).
	Step 3. Check for air in fuel system.	If air is found, prime fuel system. See (para 3-8).
	Step 4. Check to see if inlet or exhaust valves, improper adjustment.	If improperly adjusted, adjust valves (para 4-15).
<b>3. ENGINE SMOKES</b>		
	Step 1. Check to see if air cleaner is clogged.	If clogged, service air cleaner (para 3-4).
	Step 2. Inspect for defective injection valves.	If defective, replace injection valves (para 4-25).
<b>4. ENGINE OVERHEATING</b>		
	Step 1. Check to see if coolant is low.	If low add coolant.
	Step 2. Inspect for loose fan belt.	If loose, check belt tightener (para 4-40).
	Step 3. Check to see if radiator is clogging.	If it is clogging, clean radiator (para 3-9).
	Step 4. Inspect for defective thermostat.	If defective, test thermostat (para 4-36).
	Step 5. Check to see if tractor is under continuous load.	If load is continuous, reduce load.
	Step 6. Check to see if radiator sealed pressure overflow defective.	If defective clean or replace (para 4-37, and 4-38).
<b>5. ENGINE KNOCKS EXCESSIVELY</b>		
	Step 1. Check to see if crankcase oil is low.	If oil is low, fill crankcase to proper level.
	Step 2. Inspect injection valves to see if they are defective.	If defective, replace valves (see para 4-25).
<b>6. LOW OR NO LUBRICATING OIL PRESSURE</b>		
	Step 1. Check to see if crankcase oil is low.	If low refill crankcase.
	Step 2. Check to see if connections are leaking.	If leaking tighten connections.

Table 3-2. Troubleshooting Continued

MALFUNCTION	TEST OR INSPECTION	CORRECTIVE ACTION
7. LOW OR NO FUEL PRESSURE INDICATION	Step 1. Check for clogged fuel filter.	If clogged clean element in primary filter. Replace element in final filter (para 3-7).
	Step 2. Check for air in fuel system.	If air is in fuel system prime fuel system (para 3-8).
	Step 3. Inspect for defective gage.	If defective replace gage.
8. STARTER WILL NOT CRANK ENGINE	Step 1. Check to see if batteries are weak.	If weak, test batteries and charge if necessary.
	Step 2. Inspect commutator for dirty or worn condition.	If dirty or worn replace starter motor (para 4-46).
9. GENERATOR NOT CHARGING	Step 1. Inspect generator drive belt for loose or broken condition.	If loose or broken, adjust or replace drive belt. See (para 4-40).
	Step 2. Inspect generator-regulator to see if it is operative.	If inoperative, refer to paragraph 4-45.
10. GENERATOR OUTPUT OR UNSTEADY	Step 1. Inspect generator belt to see if it properly adjusted.	If not properly adjusted, adjust belt. (para 4-40).
	Step 2. Inspect commutator to see if it is dirty or worn.	If it is dirty, replace generator—see (para 4-43).
	Step 3. Check generator regulator to see if it working properly.	If generator regulator is not working properly refer to (para 4-45).
11. FULLY CHARGED AND A HIGH CHARGING RATE	Step 1. Inspect for proper voltage regulator setting.	If incorrect, adjust voltage regulator.
	Step 2. Check for poor ground connection at regulator.	If ground connections are poor, check ground connections.
12. BATTERIES WILL NOT HOLD CHARGE	Step 1. Check for loose terminals or connections.	If connections are loose, tighten connection.
	Step 2. Check for short in electrical system.	If short exists, check cables and wiring.
	Step 3. Check for defective battery. Use hydrometer.	
	Step 4. Inspect generator regulator to see if it is operating properly.	If not see para 4-45.
13. HEADLIGHT AND/OR DASH LIGHT WILL NOT LIGHT	Step 1. Inspect for burned out bulb.	If lamp is burned, replace bulb.
	Step 2. Check for defective circuit breaker.	If defective, replace circuit breaker.
	Step 3. Check for loose connections.	If loose, tighten connections.
	Step 4. Inspect to see if electrical disconnect switch in OFF position.	If not, turn switch to ON position.
14. WINCH FAILS TO OPERATE OR IS SLUGGISH IN OPERATION	Step 1. Check to see if filter is plugged or leaking.	If filter is plugged, check filter (LO).
	Step 2. Inspect for loose connections in suction line.	If connection are loose, check suction line connection (para 4-79).
	Step 3. Inspect for low oil level in winch transmission.	If low, check winch transmission oil level; add to correct level (LO).
	Step 4. Improper adjustment for push-pull cable.	If improperly adjusted, adjust valve spool and hand lever for valve for 1-inch travel of cable (para 3-16).
15. WINCH BRAKE NOT HOLDING PROPERLY	Step 1. Inspect for water in brake compartment.	If water is in compartment, remove drain plug to drain brake compartment (para 3-16 and LO).
	16. WINCH CLUTCH PRESSURE LOW	
	Step 1. Improper stroke adjustment on push-pull cable.	If adjustment is incorrect, adjust stroke (para 3-16).

Table 3-2. Troubleshooting Continued

MALFUNCTION	TEST OR INSPECTION	CORRECTIVE ACTION
	Step 2. Check filter for a plugged condition. If clogged, filter should be cleaned.	
17. RIPPER WILL NOT RAISE	Step 1. Check for low oil level. If oil pressure is low, add oil.	
18. RIPPER WILL NOT LOWER	Step 2. Inspect for oil pump failure. Inspect for low oil pressure. Check and add oil.	
19. RIPPER WILL NOT STAY IN GROUND	Inspect shank for proper adjustment. If improperly adjusted, adjust shank.	
20. TRACTOR HAS DIFFICULTY PULLING RIPPER	Inspect to see if ripper is set too deep or too many shanks being used. If ripper is set too deep or too many shanks used adjust shank depth (para 2-4.g).	
21. TRACTOR DOES NOT OPERATE IN ANY SPEED	Step 1. Check for low oil level. If oil is low, add oil. Step 2. Inspect for leakage in internal line. If leakage is discovered, check hose, lines fittings and replace defective parts (fig. 4-79)	

### Section IV. MAINTENANCE PROCEDURES

#### 3-4. Air Cleaner.

##### a. General.

(1) Regular service intervals, along with close visual inspection of the dry type air cleaner, are necessary for proper cleaning of the engine inlet air. The service interval will vary with the weather and working conditions. Where dust conditions are severe, it will be necessary to service the air cleaner frequently.

(2) Visual inspection of seals is important in keeping dust from by-passing the air cleaner. Air leakage at any of the seals can upset proper air cleaner action. If the condition of any of the replaceable seals and gaskets is questionable, replace them.

(3) Excessive engine exhaust smoke and/or loss of power may indicate the need for servicing the air cleaner.

(4) Because of the extremely high tip speeds of the turbine and compressor wheels any large particles which gain entrance through the inlet or exhaust systems can mechanically damage the rotating parts of the turbocharger. This is one of the reasons why proper maintenance of the air cleaner is extremely important and also why thorough cleaning of the inlet and exhaust systems is essential if there has been a previous turbocharger failure, valve failure or any other

type of failure which could leave foreign particles in the engine,

b. *Air Cleaner Service.* Service the air cleaner as instructed in figure 3-1.

c. *Filter Element Cleaning.* Use one of the following methods to clean filter elements. Handle elements carefully to avoid damage. Bent or dented ends will not seal properly.

(1) Using clean, dry air at a pressure not to exceed 100 psi, (pounds per square inch) proceed as follows:

(a) Direct air against inside (engine side) of element to loosen any imbedded dirt. Best results can be obtained by moving air hose so that air is directed along complete length of each pleat.

(b) Blow off loose dirt by directing air against outside of element. Repeat this procedure until element is clean. Make certain that no dirt is on engine side of element.

(2) Using clean water at a pressure not to exceed 40 psi, proceed as follows:

(a) Direct water against inside (engine side) of element to loosen any imbedded dirt. Best results can be obtained by using a water hose without a nozzle and moving it so that water is directed along complete length of each pleat.

(b) Wash off loose dirt by directing water against outside of element.

( c ) Repeat this procedure until element is dean. Make certain that no dirt is on engine side of element and thoroughly dry element before installing it.

(3) Some oily and/or sooty deposits can be removed by washing element in a solution of warm water and good household non-sudsing detergent. Rinse with clean water and dry.

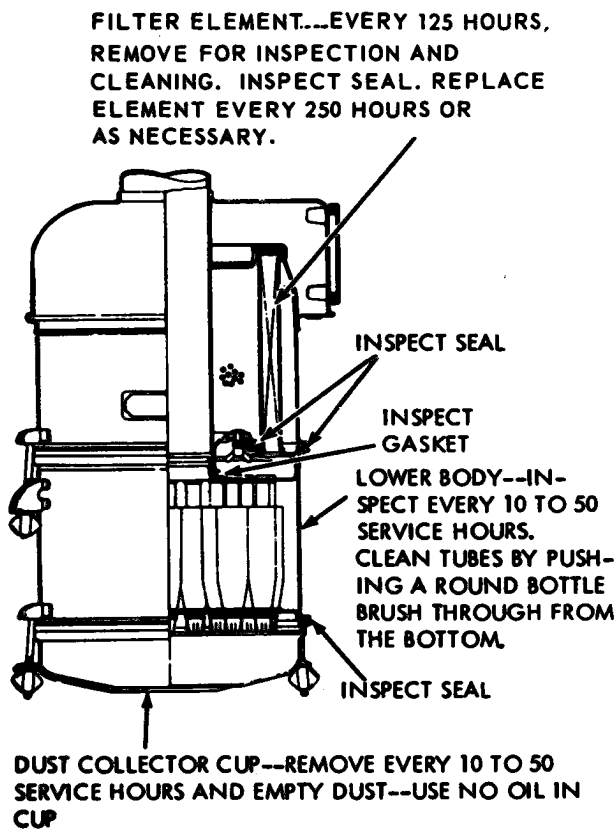

TS 003568

Figure 3-1. Air cleaner service.

### 3-5. Muffler and Exhaust Pipe

#### a. Removal.

(1) Remove clamp holding exhaust pipe to muffler (not shown).

(2) Remove hood.

(3) Remove two bolts (fig. 3-2) and remove exhaust tube assembly from muffler.

(4) Remove four nuts and bolts securing muffler straps and remove the top half of the straps from muffler.

(5) Slide muffler from the turbocharger housing and remove muffler from engine.

b. *Inspection.* Inspect muffler for cracks, dents, corrosion, broken welds or ruptures. Replace a defective muffler.

c. *Installation.* Reverse removal procedure and install the muffler on the tractor.

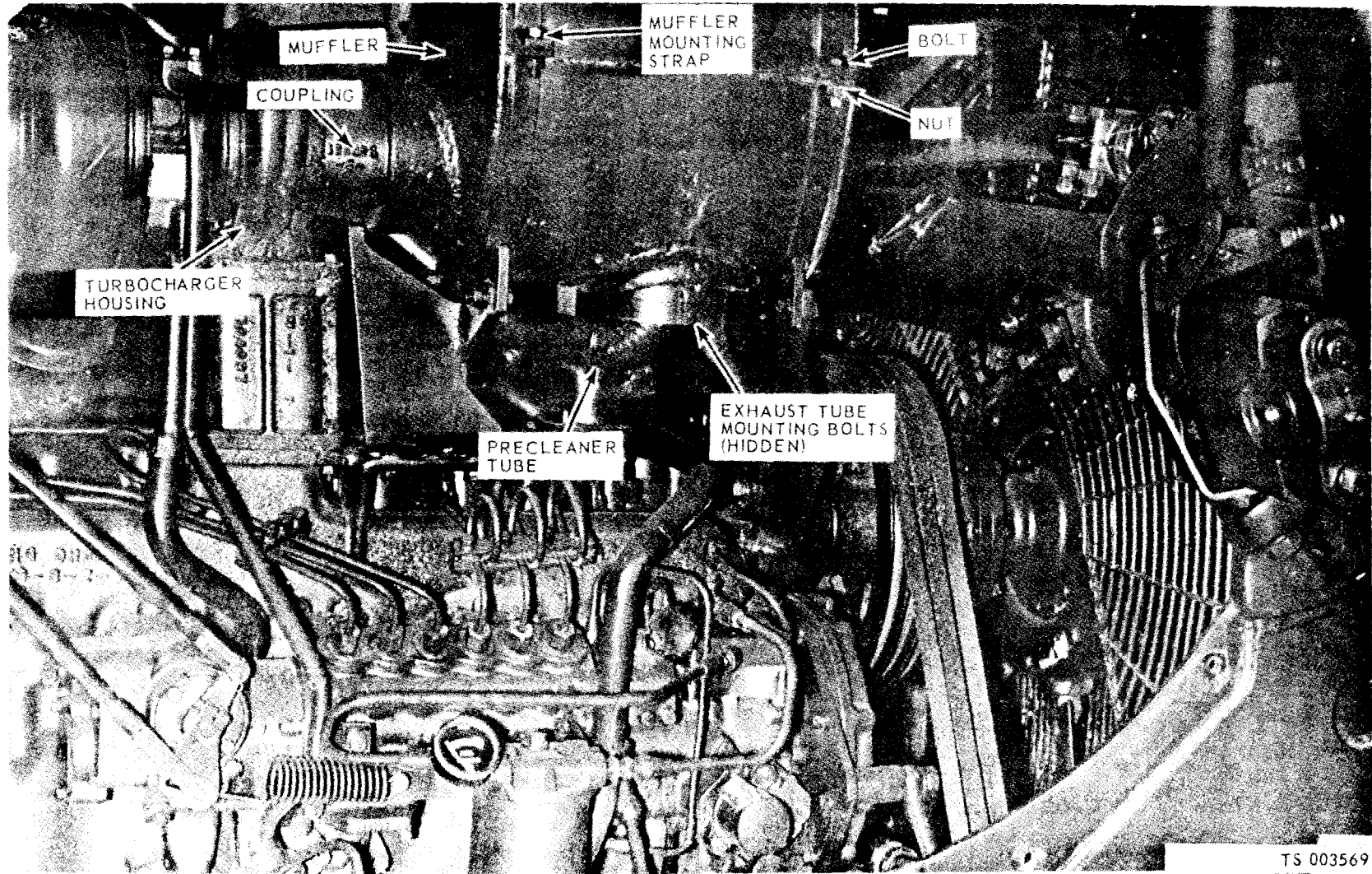

Figure 3-2. Muffler and exhaust pipe removal.

### 3-6. Fuel Tank

#### *a. Care of Fuel supply.*

(1) Keep fuel clean. containers and funnels.

(2) Natural settling is an effective method of cleaning diesel fuel. Allow fuel to stand at least 24 hours in fuel storage tank, if possible, before transfer of fuel to tractor fuel tank. Drain all water and sediment that has settled to bottom of tank.

*b. Care of Fuel Tank. Service fuel tank as illustrated in figures 3-3 and 3-4.*

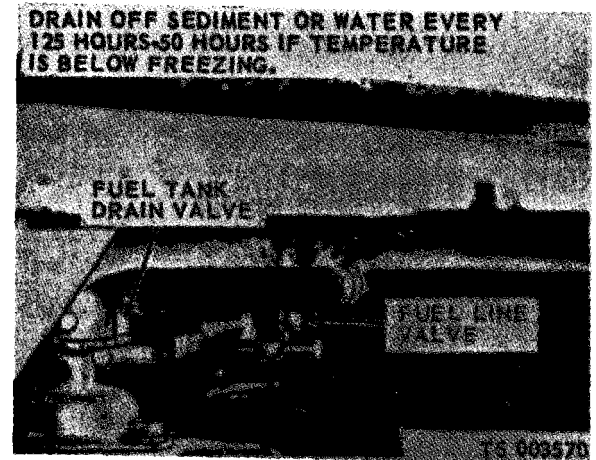

**Figure 3-3. Fuel tank drain valve and fuel line valve.**

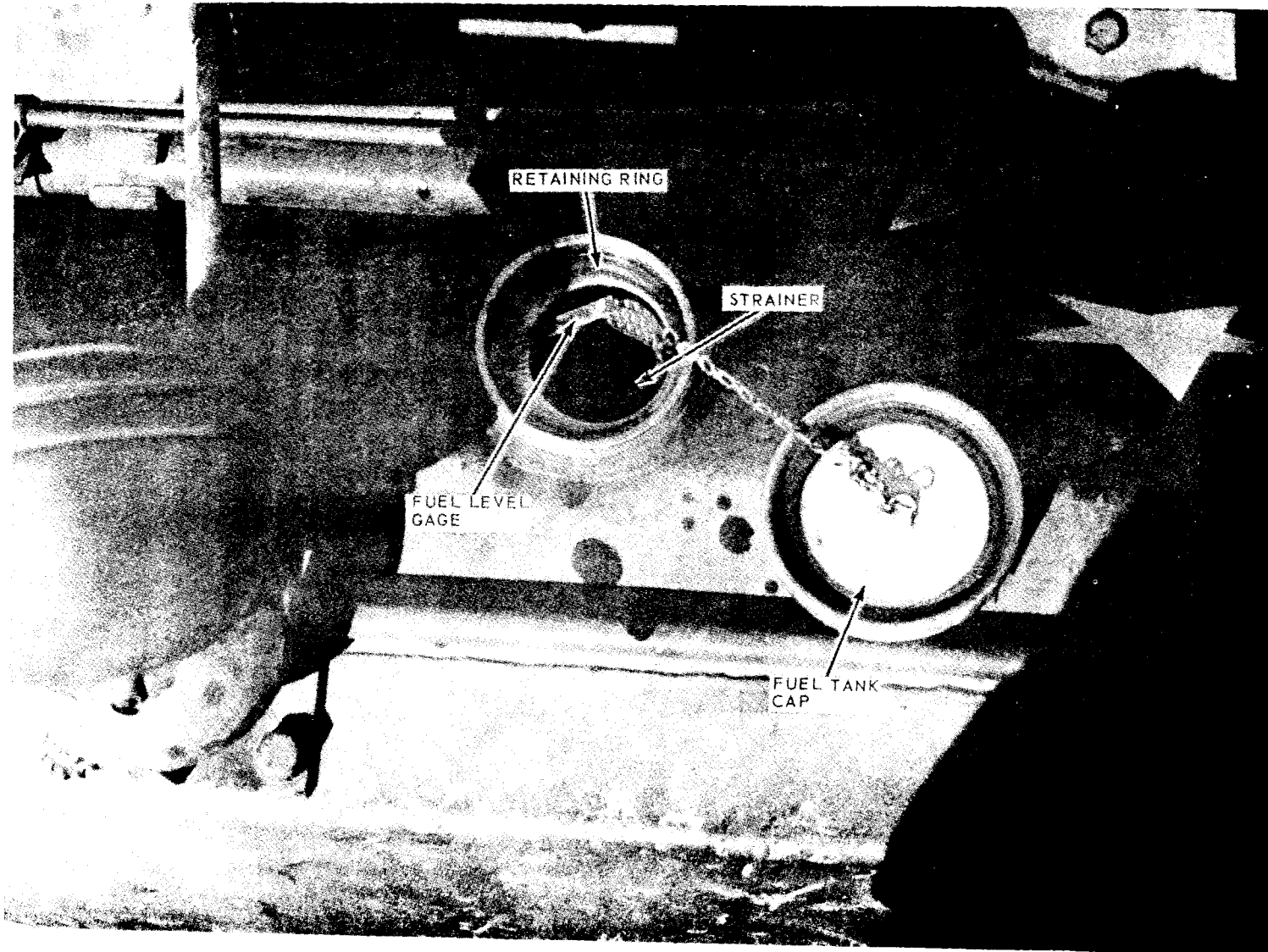

TS 003571

Figure 3-4. Fuel tank filler, strainer, and fuel level gage.



**3-7. Fuel Filters**

*a Primary Fuel Filter.* Service the primary fuel filter as illustrated in figure 3-5.

*b. Final Fuel Filter.*

(1) Drain final filter as illustrated in figure 3-

(2) Replace filter elements as illustrated in figure 3-7.

- STEP 1. STOP ENGINE AND SHUT OFF FUEL LINE VALVE (FIG. 3-3).
- STEP 2. LOOSEN NUT ON FILTER COVER AND LOWER THE CASE.
- STEP 3. REMOVE ELEMENT-WASH IN KEROSENE OR DIESEL FUEL.
- STEP 4. INSTALL CLEANED ELEMENT AND REASSEMBLE FILTER.

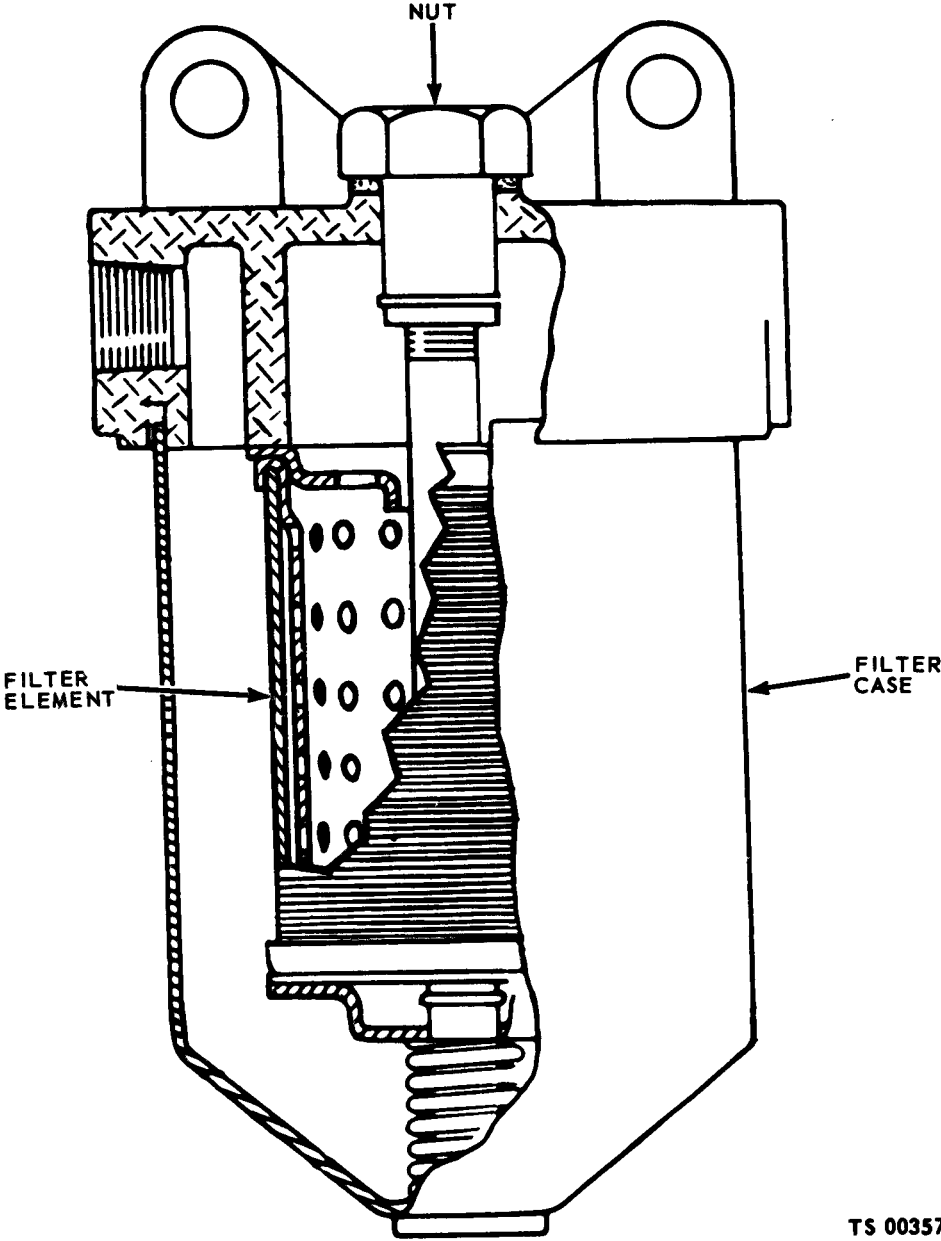

TS 003572

Figure 3-5. Primary fuel filter service.

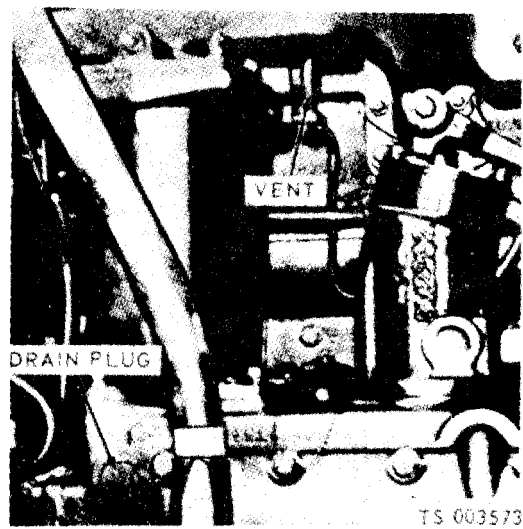

*Figure 3-6. Draining final fuel filter.*

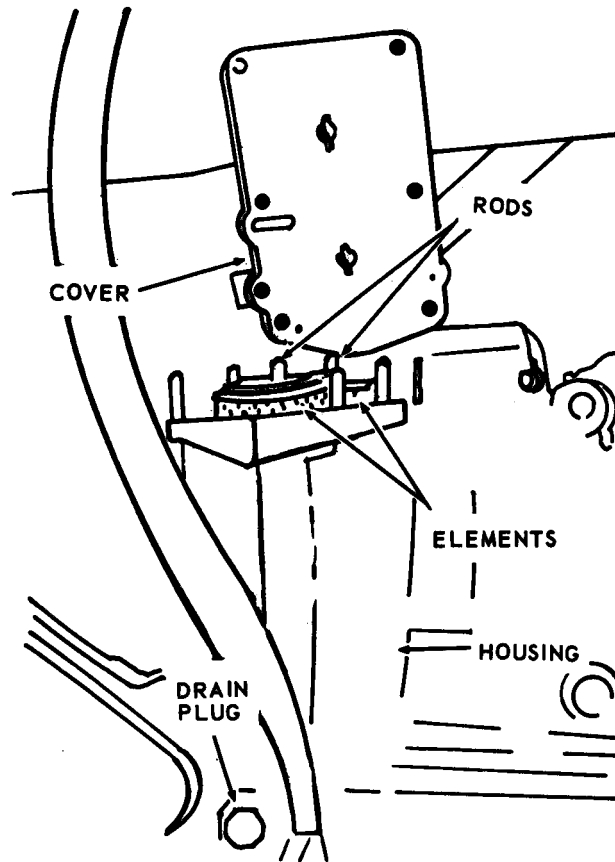

FILTER ELEMENTS COLLECT AND HOLD CONTAMINANTS AND CANNOT BE WASHED OR RESTORED. WHEN FILTERS ARE FILLED WITH CONTAMINANTS, REDUCED FUEL PRESSURE WILL BE INDICATED ON THE GAGE.

**REMOVING USED FILTER ELEMENTS**

- STEP 1. CLOSE FUEL LINE VALVE (FIGURE 3-2)
- STEP 2. REMOVE DRAIN PLUG AND OPEN VENT
- STEP 3. CLEAN COVER AND AROUND EDGES OF GASKET JOINT
- STEP 4. REMOVE COVER
- STEP 5. REMOVE ELEMENTS
- STEP 6. REMOVE RODS AND ROD SPRINGS AND CLEAN HOUSING

**INSTALLING FILTER ELEMENTS**

- STEP 1. REPLACE ROD SPRINGS AND RODS
- STEP 2. PLACE FILTER ELEMENTS OVER RODS
- STEP 3. PLACE A NEW GASKET ON THE FILTER HOUSING
- STEP 4. INSTALL COVER ON THE HOUSING--MAKE CERTAIN THE RODS ENTER DRILLED HOLES IN COVER.

TS003574

**Figure 3-7. Installing final fuel filter elements.**

**3-8. Priming the Fuel System**

a.. If fuel flow is broken and air enters the fuel system, the system must be primed. Air in the fuel system will cause hard starting or misfiring.

b. Prime the fuel system as illustrated in figure

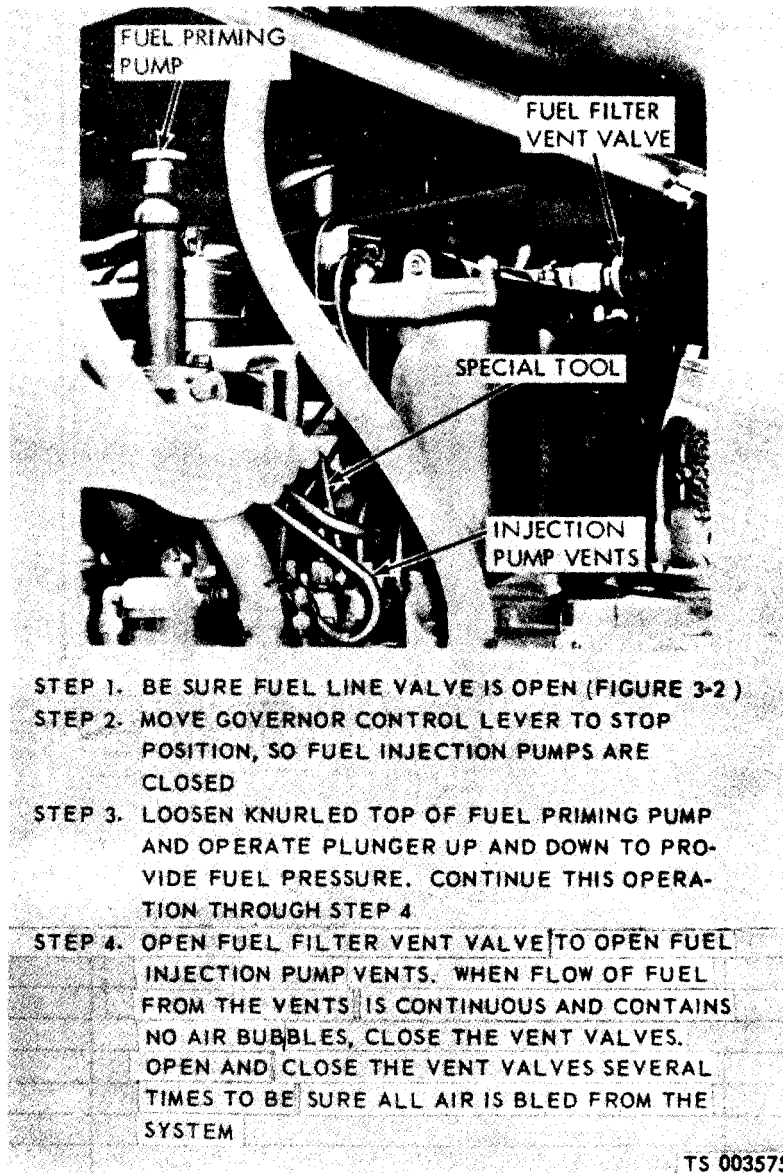

Figure 3-8. Priming the fuel system.

### 3-9. Radiator

a *Draining the Cooling System.* Drain the

cooling system. See figure 3-8 for step by step procedure.

Use clean water that is low in scale forming minerals — not softened water.

Rust Inhibitor to coolant except when using permanent type antifreeze containing rust inhibitors.

Never add coolant to an overheated engine. Allow it to cool first.

Whenever draining and refilling the cooling system, always recheck the coolant level after the engine reaches normal operating temperature. Maintain coolant level 1/2 inch below bottom of fill pipe.

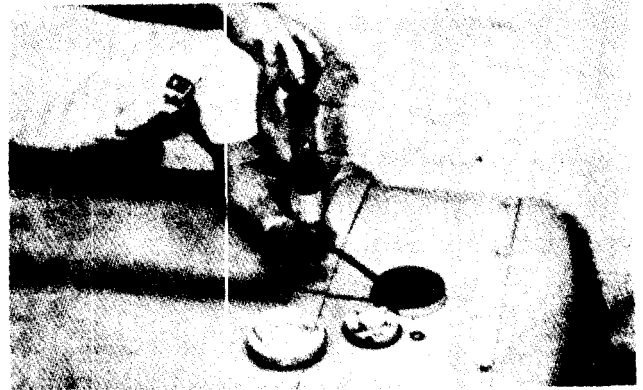

Check specific gravity of antifreeze solution frequently in cold weather to assure adequate protection:

### Cleaning Cooling System

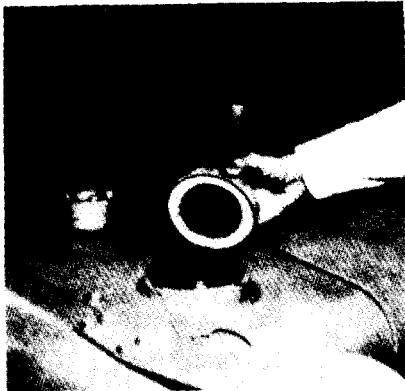

1. Run engine long enough to warm coolant. Loosen filler cap to relieve pressure.

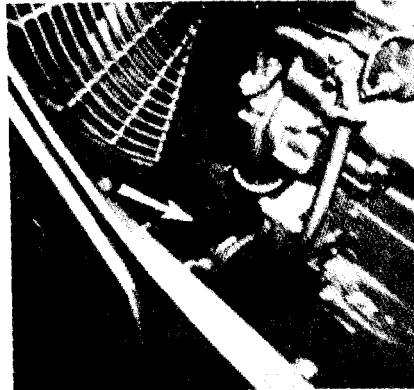

2. Remove filler cap. Open drain valve and allow coolant to drain.

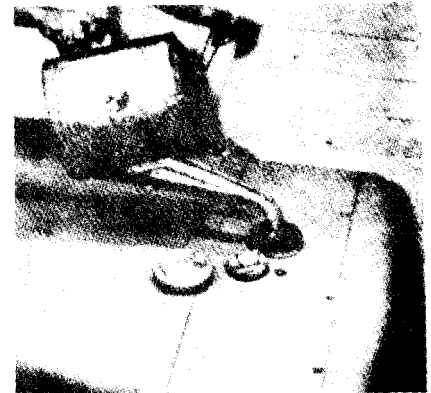

3. Close drain valve and fill system with cleaning solution.<sup>(1)</sup>

4. Start engine and operate for 1/2 hour.



5. Stop engine and open valve. Flush system with clean water until draining water is clear.

6. Close drain valve and fill system with neutralizing solution.<sup>(2)</sup>

7. Start engine and operate for 10 minutes.

8. Stop engine, open drain valve and flush system.

9. Close drain valve and add coolant to proper level.

<sup>(1)</sup> 2 lb. Sodium Bisulfate (NaHSO<sub>4</sub>) per 10 gal. water (mix 25 grams per 1 liter of water).

<sup>(2)</sup> 1/2 lb. Sodium Carbonate Crystals (Na<sub>2</sub>CO<sub>3</sub>, 10 H<sub>2</sub>O) per 10 gal. water (mix 6 grams per 1 liter of water).

**Note**

Most common cooling system cleaners may be used.

TS 003576

Figure 3-9. Cleaning cooling system.

*b. Radiator Service.* Service the radiator every 10 service hours. Wash, brush or blow the dirt out. Open perforated radiator guard before attempting to clean radiator.

### 3-10. Fan Belts

The spring load belt tightener always keeps the radiator fan belts under tension. No adjustment is required.

### 3-11. Generator Belt Adjustment

Check belt tension and adjust as illustrated in figure 3-10.

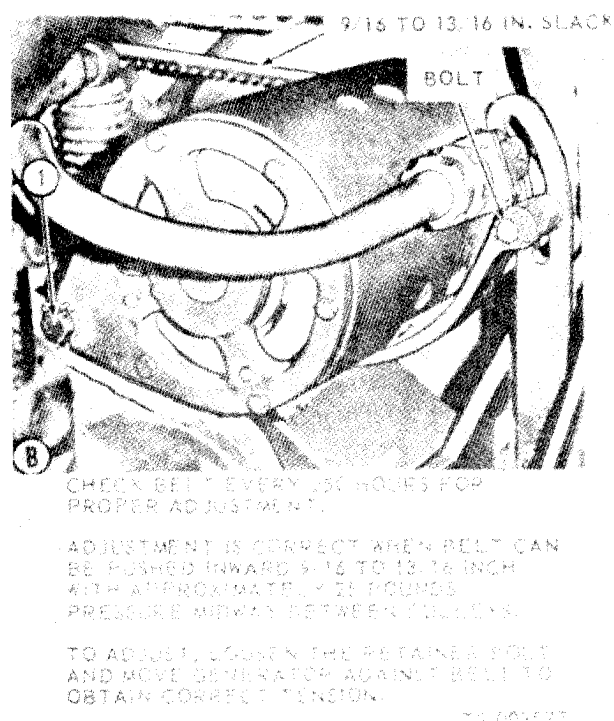

Figure 3-10. Generator belt adjustment.

### 3-12. Batteries and Cables

Batteries are located in two metal boxes on left fender. Keep terminals clean and tight. To clean corrosion from terminals, scrub with a weak solution of baking soda and water then dry battery and coat terminals with lubricant. Keep batteries securely fastened. Electrolyte level—maintain level 3/8 inch above separators by addition of die tilled water. Do not overfill or underfill.

### 3-13. Transmission, Torque Converter, and Steering Clutches Hydraulic System

Keep hoses, lines, and fittings, clean and check for damage or leakage. Report to direct support

maintenance if repairs or replacement is required.

### 3-14. Tracks

*a. Care of Tracks.* After operating in mud or slush and if freezing temperatures are expected, park tractor on solid dry ground, planks, logs, or brush to prevent tractor from freezing to the ground. Clean snow or mud from around track links, sprockets, idlers, rollers, and guards to prevent freezing of tracks.

*b. Checking Track Adjustment.* Operate tracks without tension, to avoid undue wear of moving parts. Check track adjustment as illustrated in figure 3-11.

*c. Adjusting Tracks.*

(1) Adjust tracks as illustrated in figure 3-12.

(2) If track is too tight, release pressure (with caution) as follows:

(a) Remove all dirt, sticks, or other debris that may prevent retraction of front idler.

(b) Turn relief valve one turn counterclockwise and allow grease to escape from vent holes just below relief valve.

#### **WARNING**

**Because of high pressure, never visually inspect the relief valve or fill valve to see if grease is escaping. Always observe the track to see if it has loosened.**

(c) Tighten relief valve when more than 1 ½ inches of slack has developed in track.

(3) If track does not loosen after performing (a), (b), and (c), above, proceed as follows:

(a) Turn fill valve on turn counterclockwise and allow grease to escape from vent hole (fig. 3-12).

(b) Start tractor and move backward and forward slightly.

(c) Loosen relief valve until lower hexagonal shoulder contacts underneath side of guard. This will expose unthreaded portion between upper and lower threaded sections of relief valve, allowing grease to escape through slot in lower section of threads.

(d) Loosen fill valve until hexagonal shoulder contacts underneath side of guard. This will expose unthreaded portion between upper and lower fill of valve, allowing grease to escape through slot in lower section of threads.

(e) Tighten relief valve and/or fill valve when more than 1 ½ inches slack or sag has developed in track.

(f) Adjust to obtain correct slack or sag in track.

**3-15. Hydraulic System-Dozer**

Keep hose, lines, fittings, clean and check for damage or leakage. Report to direct support maintenance if repairs or replacement is required.

**3-16. Winch**

*a Servicing Winch.* Every 200 hours, loosen winch transmission drain plugs, and remove brake compartment drain plug and drain any accumulation of water in the transmission and brake compartment.

*b. Winch Controls Adjustments.* Adjust cable ends and levers as illustrated in figure 3-13.



Figure 3-11. Checking track adjustment.



Figure 3-12. Adjusting track.

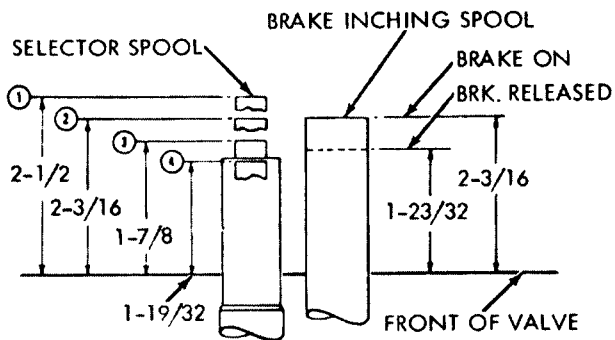

**A**

**A. CONTROL VALVE SPOOL POSITIONS.**

- STEP 1. REMOVE TOP COVER OF WINCH VALVE HOUSING BEING CAREFUL NOT TO DAMAGE GASKET.
- STEP 2. MEASURE CONTROL VALVE SPOOL AT EACH POSITION OF CONTROL LEVER.
- STEP 3. ADJUST PUSH-PULL CABLES AT CONTROL STAND TO OBTAIN MEASUREMENTS SHOWN.

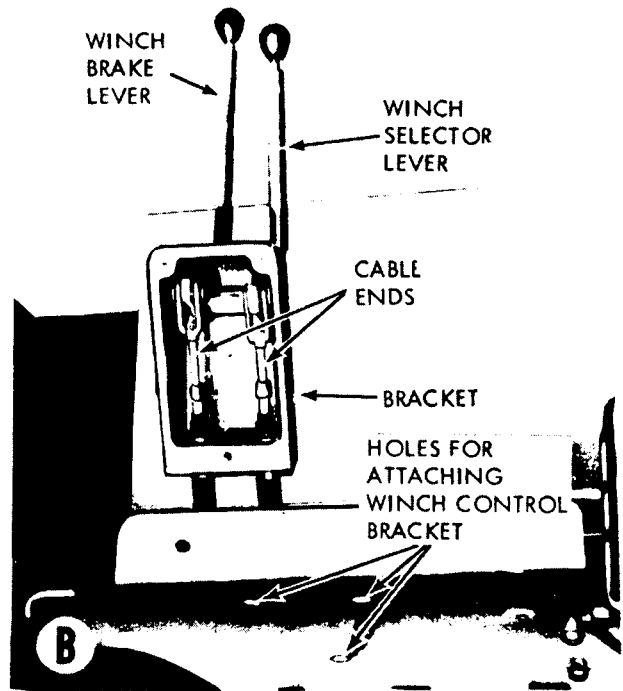

**B. ADJUSTING AT CONTROL STAND.**

- STEP 1. REMOVE ARM REST.
- STEP 2. REMOVE BOLTS AND REMOVE CONTROL BRACKET
- STEP 3. ADJUST CABLE ENDS SO THAT HAND LEVERS JUST CLEAR BOTTOM OF SLOT IN BRACKET WHEN LEVERS ARE PUSHED AWAY FROM OPERATOR.

TS 003580

*Figure 3-13. Winch controls adjustment.*

**c. Winch Brake Band. Adjust brake band as illustrated in figure 3-14.**



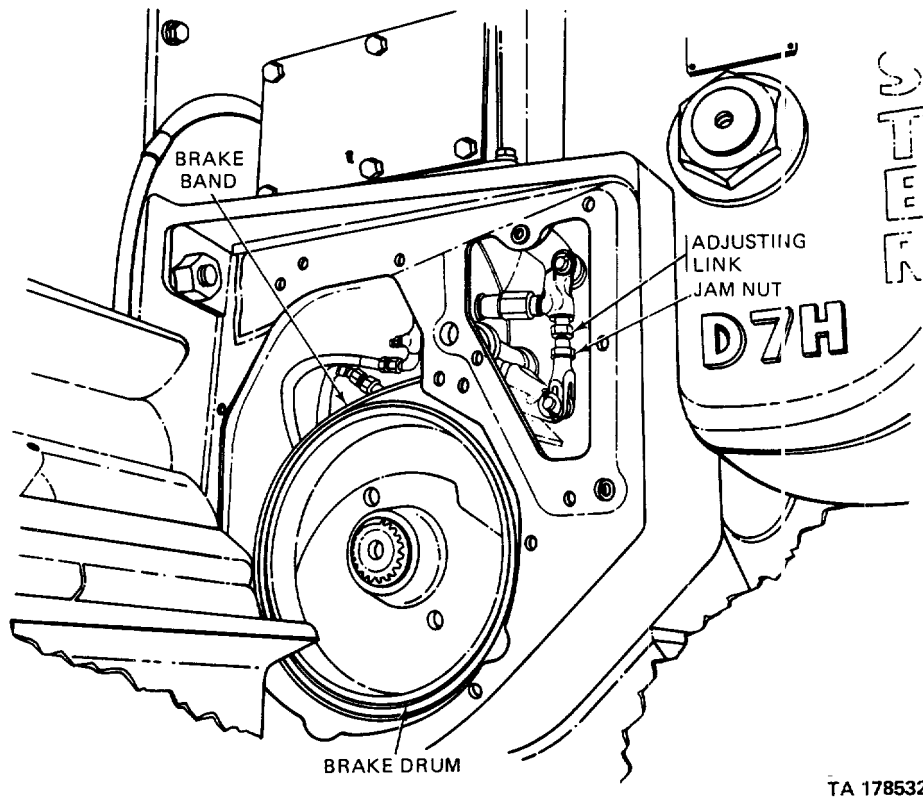

TA 178532

Figure 3-14. Winch brake band adjustment.

**3-17. Bulldozer**

*a. Removal and Installation.* Refer to figure 3-15 to remove or install the bulldozer.

*b. Replacing Cutting Edge and End Bits.* Refer to figure 3-16 to remove and install the cutting edge and end bits.

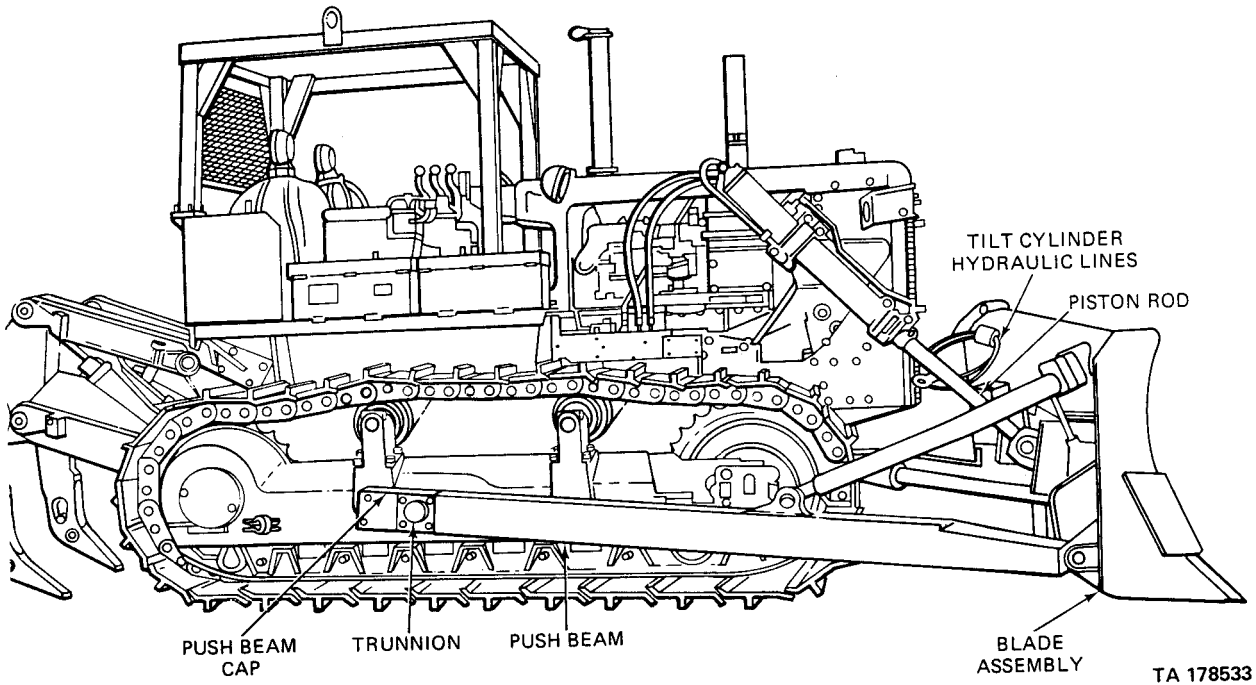

Figure 3-15. Bulldozer, removal and installation.

### 3-18. Scarifiers

Replace scarifier teeth and shanks as illustrated in figure 3-17.

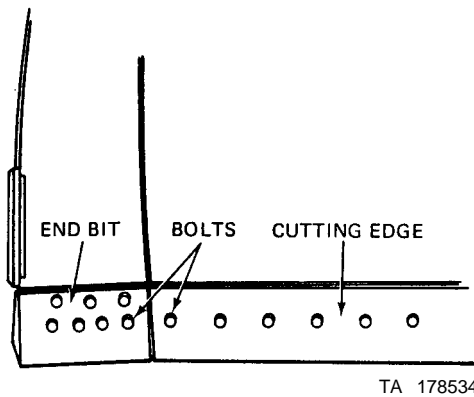
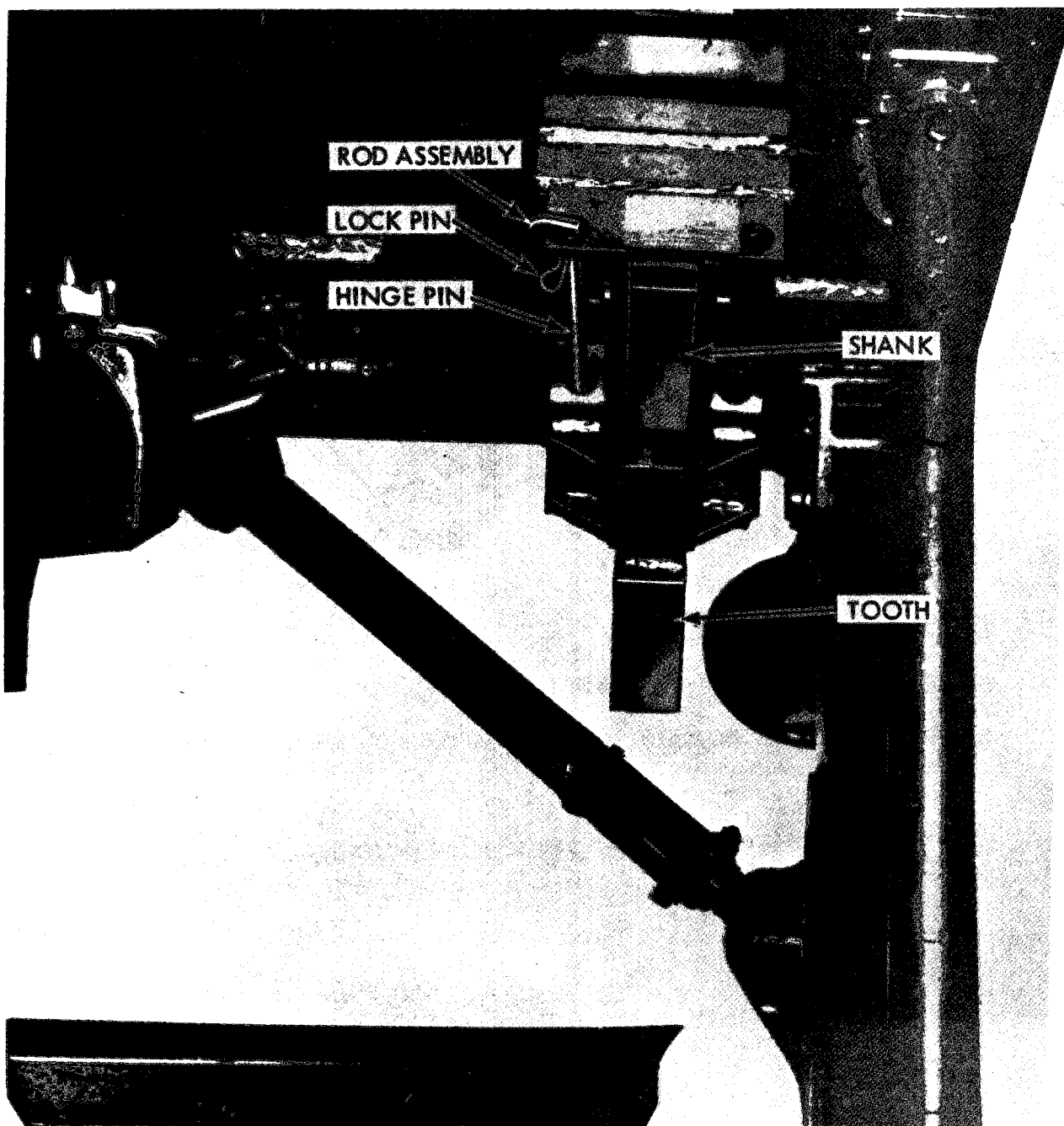

Figure 3-16. Cutting edge and end bits, removal and installation.



TS 003584

*Figure 3-17. Scanner teeth and shank replacement.*

3-19. Ripper

Replace ripper shank protectors and tips as illustrated in figure 3-18.

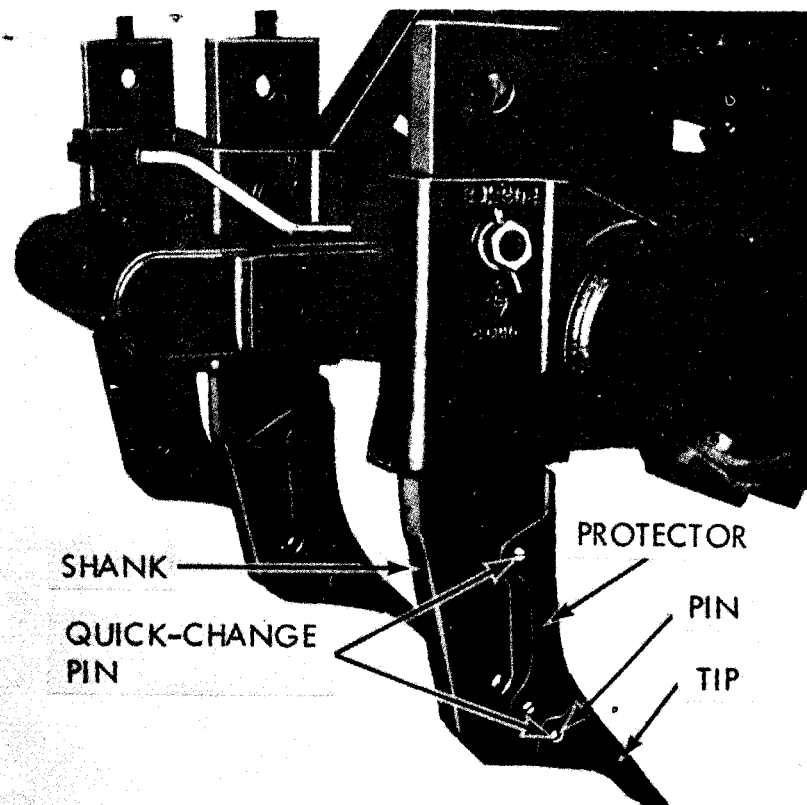

**STEP 1. RAISE THE RIPPER**

**STEP 2. REMOVE QUICK-CHANGE PINS AND TIP**

**STEP 3. REMOVE REMAINING PROTECTOR PIN, THEN REMOVE PROTECTOR**

TS 003585

*Figure 3-18. Shank protector and tip replacement.*

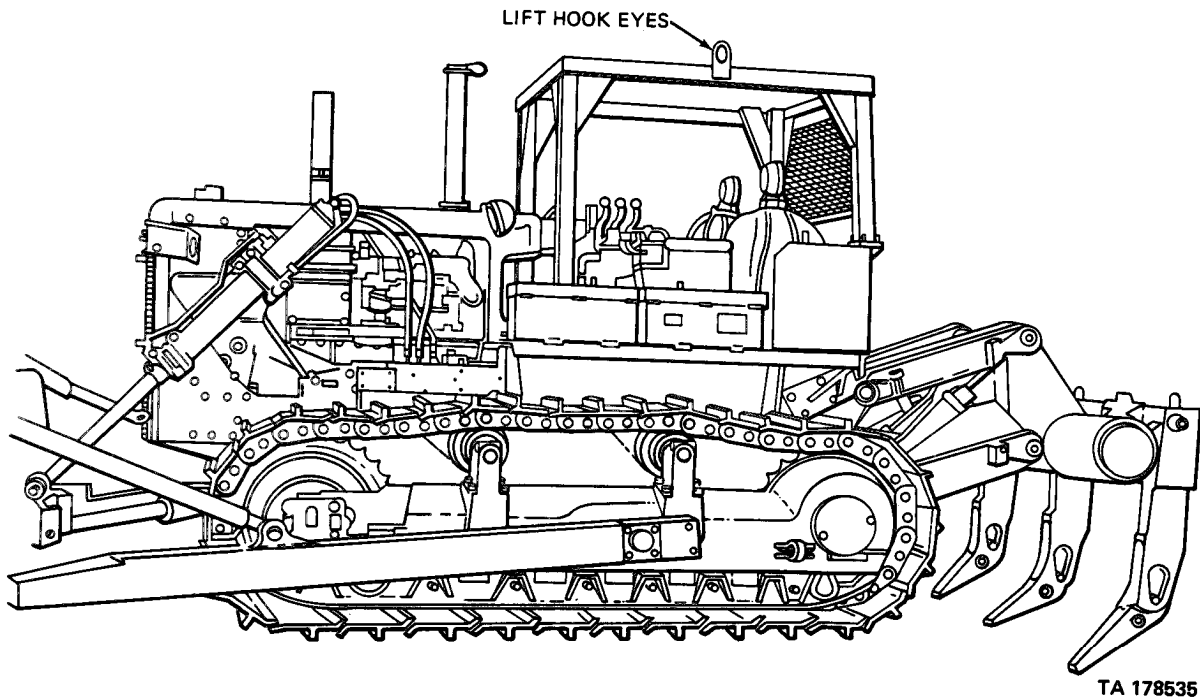

Figure 3-19. ROPS removal and installation.

### 3-20. ROPS Removal and Installation.

#### a. Removal of Canopy Structure.

(1) Attach a hoist, capable of lifting at least 1200 lbs., to the two eye hooks (fig. 3-19).

(2) Remove the four (4) bolts located on each of the two front legs. (figures 3-20 and 3-21).

(3) Remove the one (1) bolt located on each mounting riser-to-mounting bracket. (Right and left (figures 3-22 and 3-23).

(4) Remove the two (2) bolts that bolt the mounting riser to the left fender.

(5) Remove the one (1) bolt that bolts the mounting riser to the right fender.

#### b. Removal of Mounting Brackets.

(1) Remove the four (4) bolts attaching the mounting bracket to the tractor frame (right and left hand) (figures 3-22 and 3-23).

(2) Remove the mounting brackets.

#### c. Cleaning and Inspection

(1) Clean all parts with an approved cleaning solvent and dry thoroughly.

(2) Inspect ROPS structure for damage.

(3) Inspect all rubber pads and bolts and replace if necessary.

d. *Installation of Mounting Brackets.*

(1) Install the Mounting Bracket in reverse order of part b - Removal of the mounting bracket.

(2) Torque all bolts to torque values as called out in figures 3-22, and 3-23.

e. *Installation of Canopy Structure.*

(1) Install R.O.P. Structure in reverse order of part a - removal of canopy structure.

(2) Torque all bolts to torque values called out in figures 3-20, 3-21, 3-22 and 3-23.

3-21. **Seat Belt.**

a. *General*

The seat belt is designed to protect the driver in case of a roll over.

**WARNING**

The seat belt must be worn by the operator. Failure to utilize the seat belt can result in serious injury or death to the operator.

b. *Installation.*

(1) Remove the operators seat (fig. 4-59).

(2) Install the seat belt with two (2) bolts in the existing seat frame holes (figures 3-24 and 3-25).

(3) Reinstall the seat.

c. *Removal.*

(1) Remove the seat belts in reverse order of installation.

d. *Mounting hardware torque values.*

(1) Torque the two (2) 7/16" mounting bolts to 55 ft. lb.

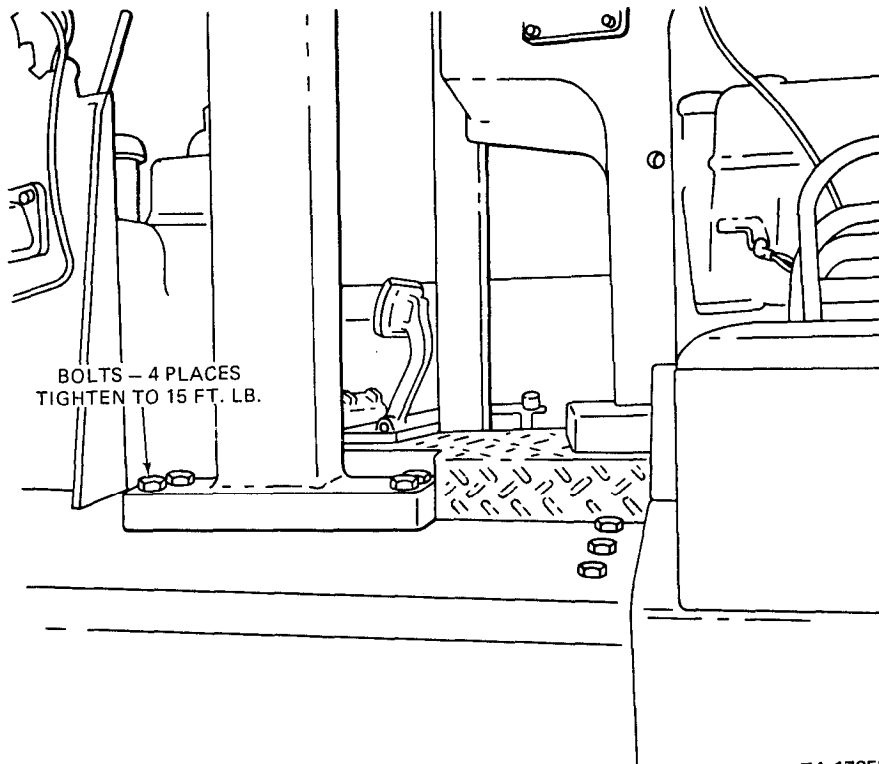

TA 178536

Figure 3-20. Right front leg, removal and installation.

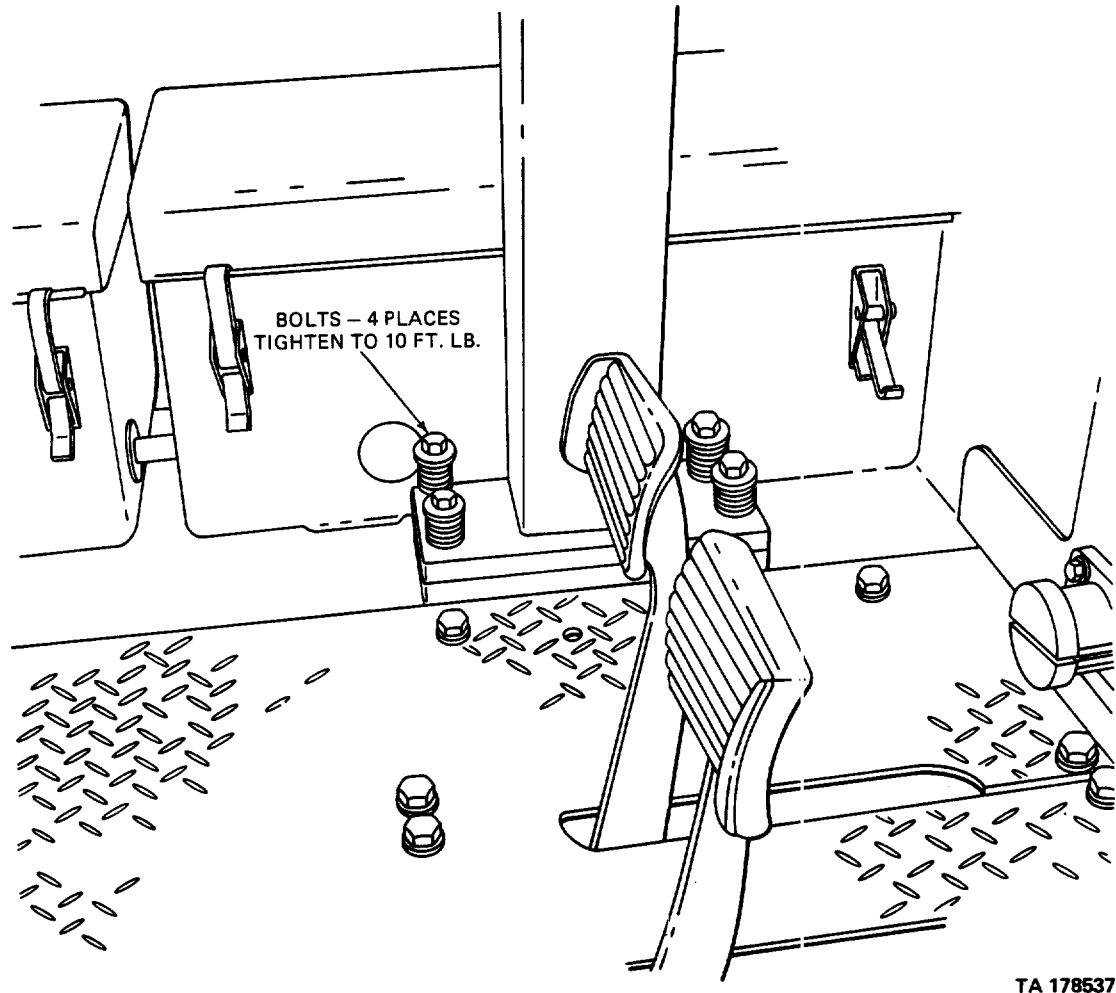

TA 178537

Figure 3-21. Left front leg, removal and installation.

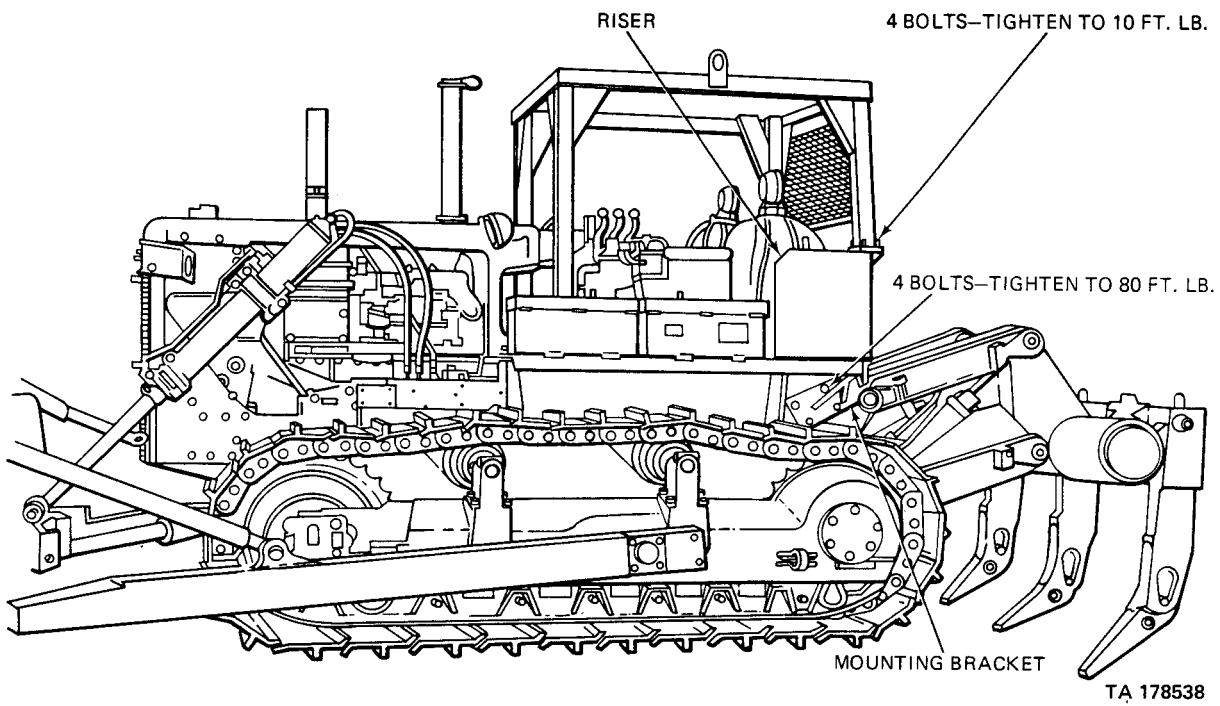

Figure 3-22. Left mounting riser and bracket, removal and installation.



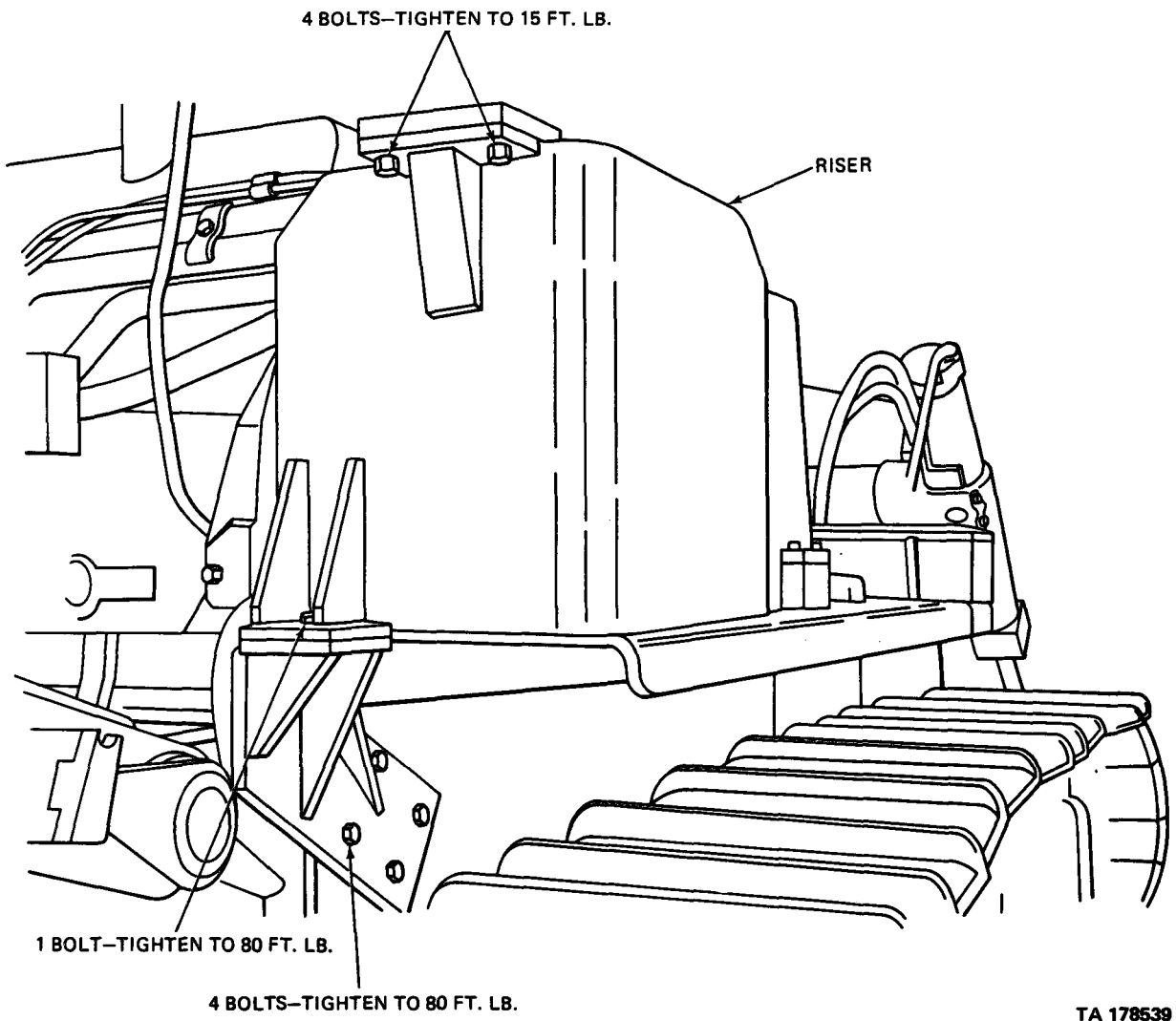

Figure 3-23. Right mounting riser and bracket, removal and installation.

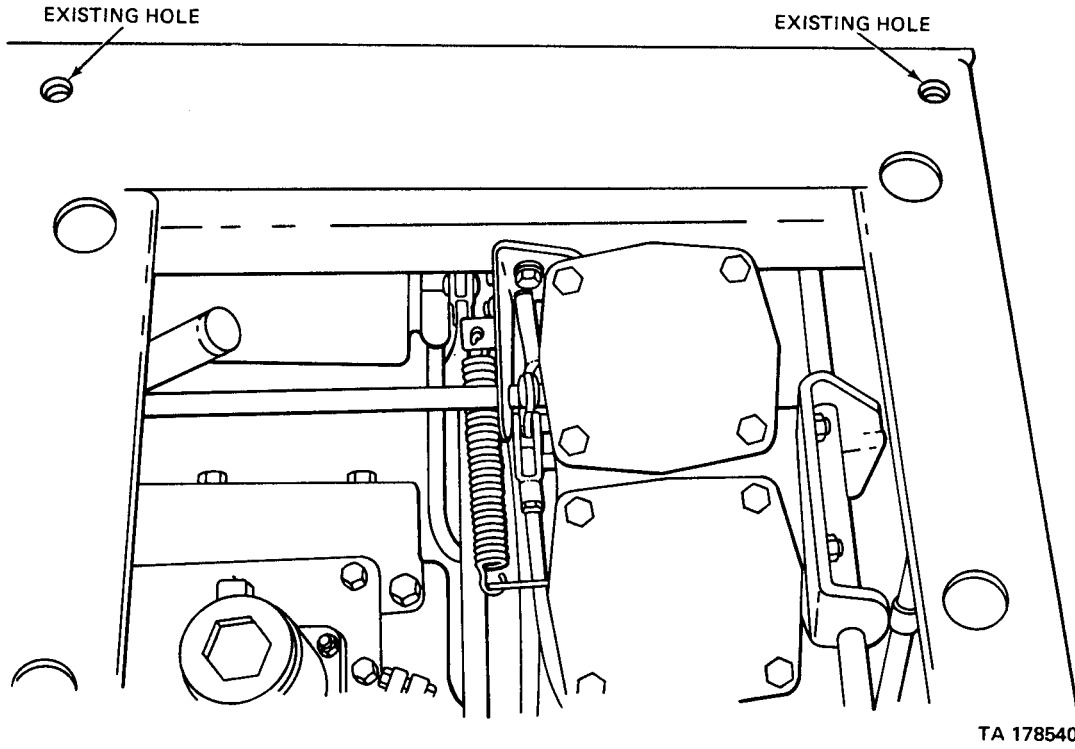
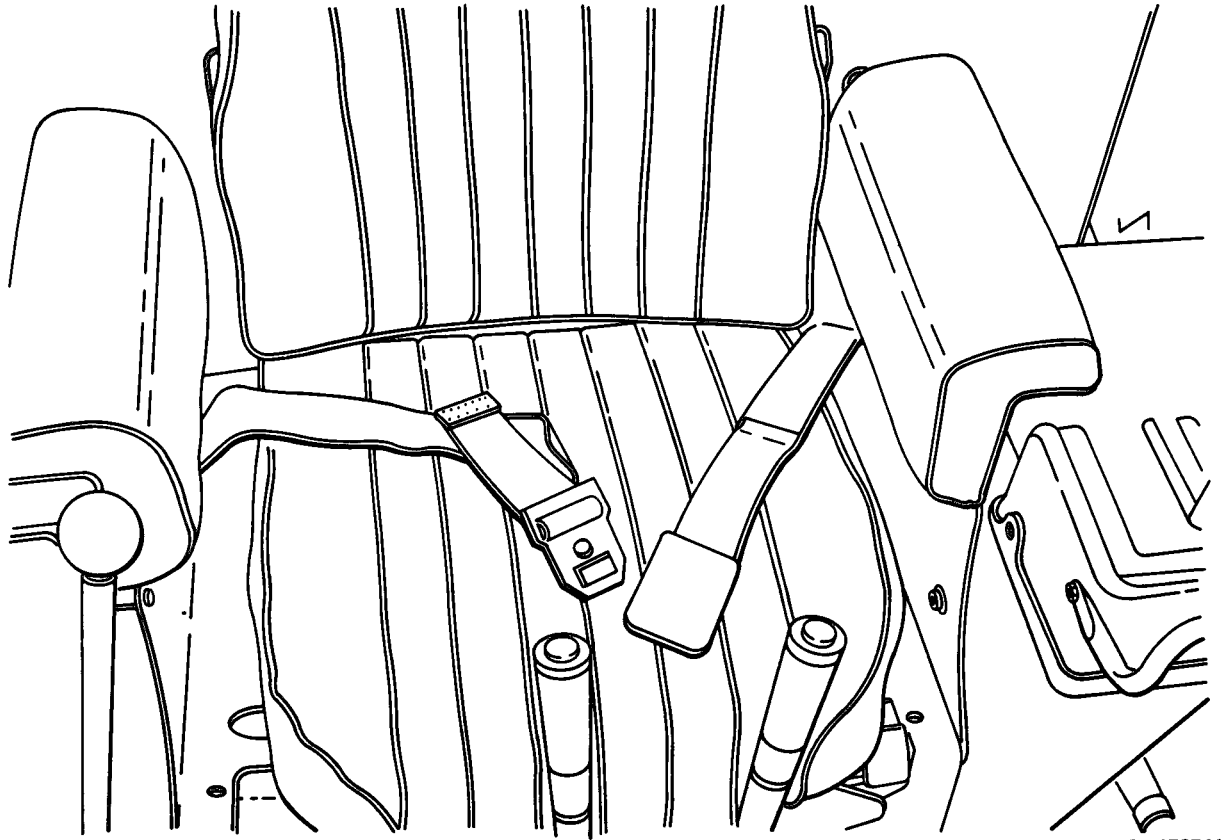

Figure 3-24. Seat belt, removal and installation.



TA 178541 ■

Figure 3-25. Seat belt, removal and installation.

## CHAPTER 4

### ORGANIZATIONAL MAINTENANCE INSTRUCTIONS

#### Section I. SERVICE UPON RECEIPT OF EQUIPMENT

##### 4-1. Inspecting and Servicing Equipment

*a* Inspect identification plates of tractor and compare with data contained in invoices, or packing slips, to insure receipt of proper equipment.

*b* Inspect the entire tractor for loose connections, broken lines or fittings, tightness of attachments, security of mounting, and freedom of operation of all controls and switches.

*c* Inspect all wiring for loose terminal connection, frayed insulation, or broken wires.

*d* Check and fill cooling system if necessary with clean soft water or approved antifreeze solution. Allow room for expansion of coolant. Install radiator cap.

##### NOTE

Refer to TB ORD 651 for proper antifreeze solutions.

*e* Inspect inside of fuel tank for presence of water, met, or foreign matter. Tractor shipped for immediate use have fuel tanks filled.

*f* *Lubrication.* Lubricate tractor in accordance with current lubrication order.

*g* Perform preventive maintenance checks and services (table 4-1).

##### 4-2. Installation of Separately Packed Components

*Batteries.* The four 12 volt batteries are located in two boxes on the left side of the tractor. Batteries are shipped in dry state and the electrolyte is shipped in a separate container. For service and test refer to TM 9-1640-200-15. Fill and connect batteries as described below. See figure 4-1.

(1) Lift batterybox covers.

(2) Remove cell caps and fill with electrolyte to 3/8 inch above separators.

(3) Make sure vent holes in cell caps are open and install caps.

(4) Connect batteries in series parallel, using interconnecting battery cables.

(5) Connect starter-to-battery cable to positive (+) terminal post of rear battery.

(6) Connect battery-to-disconnect switch cable to negative (-) post of rear battery.

(7) Tighten all lead clamps securely to post.

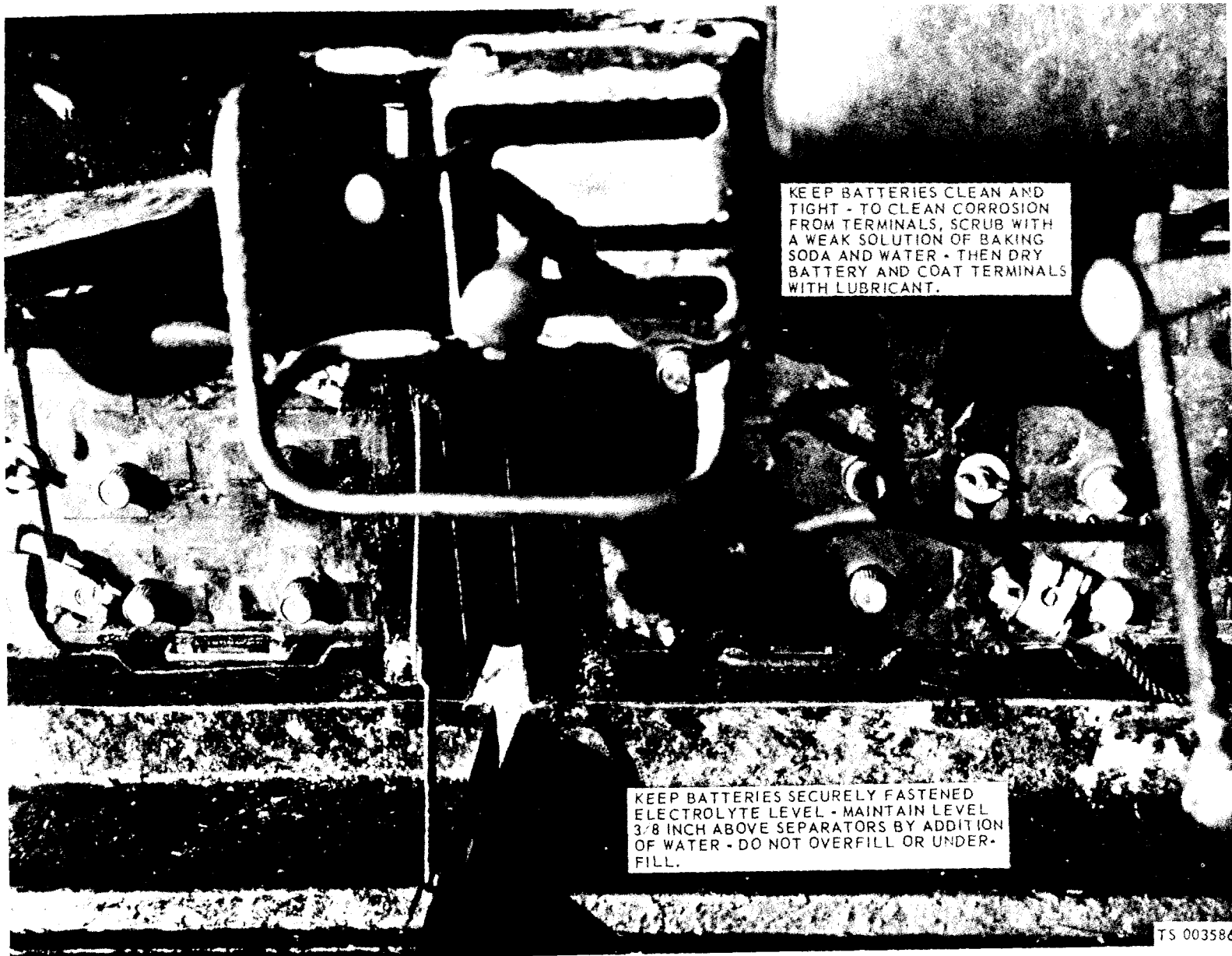

KEEP BATTERIES CLEAN AND TIGHT - TO CLEAN CORROSION FROM TERMINALS, SCRUB WITH A WEAK SOLUTION OF BAKING SODA AND WATER - THEN DRY BATTERY AND COAT TERMINALS WITH LUBRICANT.

KEEP BATTERIES SECURELY FASTENED  
ELECTROLYTE LEVEL - MAINTAIN LEVEL  
3/8 INCH ABOVE SEPARATORS BY ADDITION  
OF WATER - DO NOT OVERFILL OR UNDER-  
FILL.

TS 003586

Figure 4-1. Batteries.

**4-3. Equipment Conversion**

The Model D-7 tractor is capable of performing several functions including bulldozing, scraping,

and ripping. The only operation that requires conversion is ripping. The removal and installation of the ripper is discussed in Chapter 3.

**Section II. MOVEMENT TO A NEW WORKSITE****4-4. Dismantling for Movement**

*a. General.* When it is necessary to move to a new location, the D-7 tractor is shipped as a complete unit. The tractor may travel under its own power or it can be moved on an appropriate carrier, that is, a truck or railroad flatcar. The tractor is positional on the transporter with an adequate lifting device or driven up a ramp, blocked, and tied down.

*b. Short Distance Move.*

(1) Perform all preventive maintenance checks and services (table 4-1).

(2) Inspect bulldozer for tighteners.

(3) Inspect track for proper adjustment (para 4-63).

(4) Inspect all cooling, fuel, and oil lines. Secure if loose.

(5) Inspect V-belts and attaching hardware.

(6) Secure tools and lubricating equipment.

*c. Long Distance Move.*

(1) Position tractor on a suitable carrier and secure.

(2) Install preservative covers on air cleaners, fuel fill caps, breathers, electrical components, hydraulic fill pipes, and actuating cylinder rods.

**4-5. Reinstallation After Movement**

No special reinstallation instructions are required after movement, however the tractor should be serviced as indicated in paragraph 4-1.

**Section III. REPAIR PARTS, SPECIAL TOOLS, AND EQUIPMENT****4-6. Special Tools and Equipment**

There are no special tools required for organizational maintenance. Common tools required by Organizational Maintenance Personnel are authorized in the unit TO and E.

**4-7. Maintenance Repair Parts**

Repair parts and equipment are listed and illustrated in the Repair Parts and Special Tools List, TM 5-2410-214-20P, covering organizational maintenance for the tractor.

**Section IV. LUBRICATION INSTRUCTIONS****4-8. General Lubrication Information**

This section contains lubricating instructions which are supplemental to, and not specifically covered in the lubrication orders.

**4-9. Detailed Lubrication Information**

*a. General.* Keep all lubricants in closed containers and store in a clean, dry place away from external heat. Allow no dust, dirt or other foreign material to mix with the lubricants. Keep all lubrication clean and ready for use.

*b. Cleaning.* Keep all external parts not requiring Lubrication clean of lubricants. Before lubricating the equipment, wipe all lubrication points free of dirt and grease. Clean all lubrication points after lubricating to prevent accumulation of foreign matter.

*c. Foreign Material or Dirt in the Lubricating System.* Operating the engine with contaminated oil, under the assumption that the oil filter will remove any contaminants before they reach the bearings can be quite costly. Actually, there are certain conditions under which the oil filter is by-passed and if the oil is contaminated, turbocharger damage can result. Some examples of instances where the filter will be by-passed are as follows:

(1) When turbocharger lubrication valve is open (as it is when starting).

(2) When oil filter is clogged and by-passed valve is open.

(3) When a lubrication valve or filter by-pass

valve malfunctions (as a result of worn or binding components).

d. Contaminated oil actually will cause damage to the turbocharger bearings when this oil is permitted to enter in an amount sufficient to wear out the turbocharger bearings or when the contaminating particles are large enough to plug the internal oil passages and starve the turbocharger for oil.

e. *Points of Lubrication.* Service the lubrication points at proper intervals as illustrated on lubrication orders LO 5-2410-214-12-1 and LO 5-2410-214-12-2. Over greasing may damage seals, causing leakage. Apply grease to fittings only until it begins to ooze from the part

being lubricated; unless other wise specified. Do not under lubricate as this causes wear on moving parts.

f. *Oil Can Points.* Lubricate all miscellaneous points, not equipped with fittings, with engine oil every 50 service hours.

g. *Lubrication Intervals.* The established intervals in the lubrication order and maintenance instructions are given in service hours. The intervals indicated are for normal service. For operating in water, dust, or mud, lubricate more frequently where grease fittings are used. Clean the fittings before lubricating so that dirt will not be carried in with the lubricant.

### Section V. PREVENTIVE MAINTENANCE CHECKS AND SERVICES

This section contains information useful in keeping the Model D-7E tractor ready for service at all times. The necessary preventive maintenance checks and services are listed in Table 4-1.

Table 4-1. Organizational Preventive Maintenance Checks and Services

Q-Quarterly  
Total man-hours required: 9.1

Sequence Number	Item to be inspected procedure	Work time (M / H)
	<b>NOTE</b> Visually inspect concurrently with the Daily Checks and Services for evidence of coolant, lubricant and fuel leaks.	
1	<b>SUSPENSION SYSTEM</b> Track. Inspect for broken center guides, missing track shoe pads, cracked shoes, missing rubber inserts and worn bushings. If shoe, shoe bushings, etc. are defective or appear excessively worn, notify Organizational Maintenance.	0.5
2	<b>ENGINE OIL LEVER</b> Check for proper oil level.	0.1
3	<b>INDICATORS, GAGES, METERS</b> Check for proper operation: Engine temperature gage within operating range; Ammeter-on the + side of zero; engine lubricating oil pressure gage within operating (green) range; fuel pressure gage within operating (green) range. Torque converter temperature gage within operating (green) range. Transmission operating oil pressure gage within operating (green) range.	0.3
4	<b>FUEL</b> Check fuel supply. See that fuel tank is full. Use only approved diesel fuel.	0.4
5	<b>AIR RESTRICTION INDICATOR</b> Regular service intervals along with close visual inspection of the dry type air cleaner, are necessary for proper cleaning of the engine air inlet. The service interval will vary with the weather and working conditions. Where dust conditions are severe, it will be necessary to service the air cleaner frequently. Visually inspect seals to be sure that no dust has bypassed the air cleaner. If the condition of any of the replaceable seals and gaskets is questionable, replace them.	0.7
6	<b>RADIATOR</b> Check coolant level. Check for leaks in core lines, hoses, and gaskets.	0.3
7	<b>BELTS</b> Check condition of fan belts and generator belt. The spring loaded belt tightener keeps the fan belt at correct tension. Generator belt deflection should be 9/16" to 13/16" at midway point.	0.1

Table 4-1. Organizational Preventive Maintenance Checks and Services Continued

Q - Quarterly  
 Total man-hour required: 9.1

Sequence Number	Item to be inspected procedure	Work time (M H)
8	<b>BATTERIES</b> Check top of battery. Check electrolyte level. Inspect terminals for corrosion and tightness. Inspect batteries for cracks. Check specific gravity of battery electrolyte with hydrometer. Fully charged batteries read between 1.270 and 1.285. Recharge or replace batteries when specific gravity reading is below 1.240. Inspect retainers and connections for damage and corrosion.	0.3
9	<b>ENGINE VALVE ADJUSTMENT</b> Check diesel engine valve adjustment if excessive tappet noise or loss of power is noticed. Make sure valve tappets, rocker arms, and valve cover gaskets are in good condition. Check to see if oil is being delivered to the valve mechanism. Proper valve adjustment is a clearance of 0.016 in. for intake valve and 0.025 in. for exhaust valve with engine hot (500 hrs).	0.5
10	<b>ENGINE OIL PAN</b> Check the diesel engine oil pan to make sure that drain plugs are tight and gaskets are not leaking. Check engine breather pipe to see that it is not plugged.	0.3
11	<b>LINES AND GASKETS</b> Check oil filter, cooler lines, and gaskets for leaks.	0.2
12	<b>HYDRAULIC PUMPS</b> Check all hydraulic pumps, transmission and dozer winch hose connection for leaks. Check for dirt in dozer hydraulic tank fill tube screen. Inspect hose connections at filters and magnetic screens. Inspect cylinders for leaks.	0.4
13	<b>TRANSMISSION</b> Inspect transmission and torque divider gaskets, seals and hydraulic lines for leaks.	0.5
14	<b>PROPELLER SHAFT UNIVERSAL JOINT</b> The propeller shaft universal joint should be lubricated each quarter-of a year. With the transmission in neutral, rotate the universal joint and check for looseness of bearing caps on the cross pieces. If bearing caps show looseness, the assembly should be replaced as worn needle bearings can hang up and cause the shaft to separate and damage the splines which would require teardown of the transmission. Report to direct support maintenance for replacement of the universal joint.	0.5
15	<b>TRACKS</b> Inspect the tracks, links, pins, bushings, for wear, or fracture. Check idlers and rollers for loose mounting, leaky seals, and excessive wear. Check tension for 1 to 1 1/4 inch sag.	0.5
16	<b>FUEL LINES VALVES</b> Check fuel lines, shut-off valve, and drain valve for possible leaks. Check fuel tank cap to see that the vent is open. See that gaskets or seals are not defective.	0.3
17	<b>FINAL DRIVE</b> Inspect final drive housing, gaskets and seals for leaks and loose mounting screws.	0.2
18	<b>GOVERNOR CONTROL</b> Inspect governor control linkage to make sure it is working freely and properly adjusted. (See fig. 4-14).	0.5
19	<b>STEERING CLUTCH BRAKE</b> Clutch and adjust the steering clutch brakes. Turn the adjusting screw until the brake band is tight. Back off 1 1/2 turns.	0.5
20	<b>LIGHTS</b> Check operation of all lights. Inspect for loose mountings, broken or deteriorated wiring, and broken or dirty lenses. Inspect light switches.	0.5
21	<b>AIR CLEANER</b> Inspect air cleaner for looseness or leaks in the system.	0.3
22	<b>WATER PUMP</b> Check water pump for leaks. Check for leaks on the pump as well as gasket (See fig. 4-1).	0.2
23	<b>BULLDOZER</b> Inspect cutting edge and end bit for wear. Check all sockets and mounting pins for wear.	0.5
24	<b>WINCH</b> Loosen winch transmission drain plugs and drain any accumulation of water in transmission. Remove brake compartment drain plug and drain any water which may have accumulated. (200 hours).	0.5



## Section VI. TROUBLESHOOTING

This section provides information useful in diagnosing and correcting unsatisfactory operation of the D-7E tractor and its components. Malfunctions which may occur are listed in table

4-2. Each malfunction stated is followed by a list of possible causes of the trouble. The corrective action recommended is described opposite the probable cause.

Table 4-2. Troubleshooting

MALFUNCTION	TEST OR INSPECTION	CORRECTIVE ACTION
<b>1. ENGINE FAILS TO START</b>		
	Step 1. Check to see if there is air in system.	If air is in system, prime fuel system (para 3-8).
	Step 2. Check to see if engine is too cold.	If engine is too cold use starting aid (para 2-3).
	Step 3. Check to see if engine is out of fuel.	If engine is out of fuel, fill tank.
	Step 4. Inspect fuel filters to see if they are clogged.	If clogged clean element in primary filter, replace elements in final filter (see fig. 4-26).
	Step 5. Check injection valve to see if valves are clogged.	If valves are clogged, replace valves.
	Step 6. Check for defective injector pump.	If injector pump is defective, replace injector pump (para 4-26).
	Step 7. Inspect fuel transfer pump for defects.	If defective replace transfer pump (para 4-28).
<b>2. IRREGULAR ENGINE FIRING</b>		
	Step 1. Check for clogged filter elements.	If clogged, clean element in primary filter. Replace elements in final filter (para 4-31).
	Step 2. Check for clogged air cleaner.	If air cleaner is clogged, service air cleaner (see para 3-4).
	Step 3. Check for air in fuel system.	If air is found in the fuel system, prime fuel system (see fig. 3-8).
	Step 4. Inspect injector valves for defects.	If injector valves are defective, replace injector valves.
	Step 5. Inspect inlet and exhaust valves for proper adjustment.	If valves are improperly adjusted, adjust valves.
<b>3. ENGINE SMOKES</b>		
	Step 1. Inspect air cleaner to see if it is clogged.	If clogged, service air cleaner. Visually inspect seals. Air leakage at any of the seals can upset proper cleaning action. Service the air cleaner as seen in figure 3-4. Direct air against inside (engine side) of element to loosen any imbedded dirt. Best results can be obtained by moving air hose so that air is directed against complete length of each pleat. Service cleaner as shown in figure 3-4.
	Step 2. Inspect for defective injector valves.	If injector valves are defective, replace valves. Test for defective valve may be made by loosening the fuel injection line nuts at the fuel injection pumps, one at a time while the engine is running. When a nut is loosened and the exhaust smoking is completely or partially eliminated, and the irregularity in running is not affected, this identifies the defective valve and a new one should be installed in that cylinder. (See fig. 4-19).
<b>4. ENGINE OVERHEATING</b>		
	Step 1. Check for low coolant level.	If coolant is low, add coolant (para 3-9).

Table 4-2. Troubleshooting Continued

MALFUNCTION	TEST OR INSPECTION	CORRECTIVE ACTION
	Step 2. Check for loose fan belts.	If fan belt is loose see para 4-40 and tighten belt.
	Step 3. Inspect to see if radiator is clogged.	If radiator is clogged, drain the cooling system. <ul style="list-style-type: none"> <li>a. Wash the cooling system by running the engine until liquid in the cooling system is at operating temperature, and loose foreign material is stirred up.</li> <li>b. Stop engine and drain as soon as possible.</li> <li>c. Close drains and use about 2½ lbs of sodium bicarbonate to 10 gallons of water. Run engine at least 10 minutes after reaching operating temperature.</li> <li>d. Drain and flush system.</li> </ul>
	Step 4. Check for defective thermostat.	Method of checking the two thermostats is to remove them as illustrated in paragraph 4-36. <ul style="list-style-type: none"> <li>a. Remove thermostat from cover.</li> <li>b. Suspend thermostat in a pan of water.</li> <li>c. Apply heat to the pan and stir the water to maintain uniformity.</li> <li>d. Use an accurate thermometer to check water temperature.</li> <li>e. Observe the opening temperature of the thermostat.</li> <li>f. Replace the thermostat if it does not operate correctly.</li> </ul>
	Step 5. Check for continuous load.	If load is too great, reduce load.
	Step 6. Inspect radiator sealed pressure overflow for defective condition. If pressure overflow is defective, clean or replace.	
	Step 7. Check for debris in crankcase guard.	If debris is found it should be removed. Dust, dirt, mud and other debris, which are good insulating materials, packed in the crankcase guard can cause the temperature of the crankcase oil and the transmission oil to be raised to such an extent that overheating of the engine coolant may result.
<b>NOTE</b>		
Altitude. The altitude at which the engine is operating should be considered when boiling is encountered. The horsepower of the engine is decreased as the altitude increases. Also, the boiling point of water is lower at higher altitudes.		
<b>5. ENGINE KNOCKS EXCESSIVELY</b>		
	Step 1. Check to see if there is adequate lubricating oil.	If oil is not filled to proper level, add oil.
	Step 2. Check for defective injection valves.	If injection valves are defective, replace valves.
<b>6. LOW OR NO LUBRICATING OIL PRESSURE</b>		
	Step 1. Check to see if oil level is low.	If oil level is low, check and refill crankcase.
	Step 2. Check for leaking connections.	If connections are leaking, tighten connections.
<b>7. LOW OR NO FUEL PRESSURE INDICATION</b>		
	Step 1. Check for clogged fuel filters.	Clean element in primary filter. Replace element in final filter (para 4-31).
	Step 2. Inspect for air in fuel system.	If there is air in fuel system, prime fuel system (para 3-8).
	Step 3. Inspect for defective gage.	If gage is defective, replace gage.
<b>8. STARTER WILL NOT CRANK ENGINE</b>		
	Step 1. Check to see if batteries are weak.	If batteries are weak, change batteries.
	Step 2. Check for loose connections or defective wiring.	If loose, tighten any electrical connections.
	Step 3. Inspect commutator to see if it is dirty or worn.	If commutator is dirty or worn, replace starter motor (para 4-46).

Table 4-2. Troubleshooting Continued.

MALFUNCTION	TEST OR INSPECTION	CORRECTIVE ACTION
<b>9. GENERATOR NOT CHARGING</b>		
	Step 1. Check generator drive belt to see if it is loose or broken.	If loose or broken, replace drive belt (para 4-40).
	Step 2. Inspect generator regulator to see if it is operative.	If regulator is inoperative, see paragraph 4-45).
	Step 3. Inspect generator to see if it is inoperative.	If generator is inoperative, refer to paragraph 4-44).
<b>10. GENERATOR OUTPUT LOW OR UNSTEADY</b>		
	Step 1. Check to see if generator belt is properly adjusted.	If not properly adjusted, adjust belt (para 4-40).
	Step 2. Inspect commutator to see if it is dirty or worn.	If commutator is dirty or worn, replace generator.
	Step 3. Check to see if generator regulator is operating properly.	If it is not working properly, refer to paragraph 4-45.
<b>11. FULLY CHARGED BATTERY AND A HIGH CHARGING RATE</b>		
	Step 1. Check voltage regulator for proper setting.	If regulator is not set properly adjust regulator (para 4-45).
	Step 2. Inspect for poor ground connections.	If ground connections are poor, clean and tighten connections.
<b>12. BATTERIES WILL NOT HOLD CHARGE</b>		
	Step 1. Inspect for loose terminals or connections.	If terminals are loose, tighten connections.
	Step 2. Check for shorts in electrical system.	If shorts are discovered, tighten cables and wiring. Tape exposed or frayed cables.
	Step 3. Check for defective battery.	By use of a hydrometer, if one cell is 40 points less than the other cells, battery should be replaced.
	Step 4. Check to see if generator regulator is operating properly.	If regulator is not working properly, refer to paragraph 4-45).
<b>13. HEADLIGHT AND /OR DASHLIGHT WILL NOT LIGHT</b>		
	Step 1. Check to see if bulb is burned out.	If bulb is burned out, replace bulb.
	Step 2. Inspect circuit breaker for defects.	If circuit breaker is defective, replace circuit breaker.
	Step 3. Inspect wiring for loose connection.	If connections are loose, tighten connections.
	Step 4. Check electrical disconnect switch to see if it is in OFF position.	If it is in OFF position, turn switch ON.
<b>14. WINCH FAILS TO OPERATE OR IS SLUGGISH IN OPERATION</b>		
	Step 1. Inspect filter to see if it is plugged or leaking.	If plugged or leaking, see LO.
	Step 2. Check suction line for loose connections.	If suction lines are loose, see figure 4-68).
	Step 3. Inspect for low oil level in winch transmission.	If low, fill to correct level, see LO.
	Step 4. Check for improper adjustment of push-pull cable.	If improperly adjusted, adjust spool and hand lever for 1-inch travel of cable (para 3-16).
<b>15. WINCH BRAKE NOT HOLDING PROPERLY</b>		
	Step 1. Check for water in brake compartment.	If water is in brake compartment, drain compartment (see LO).
	Step 2. Inspect for proper brake band adjustment.	If improperly adjusted, adjust brake band (para 3-16).
	Step 3. Check for oil on brake band.	If oil is found on brake band, clean or replace brake band (para 3-16).
<b>16. WINCH CLUTCH PRESSURE LOW</b>		
	Step 1. Improper stroke adjustment on push-pull cable.	If improperly adjusted, adjust stroke (para 3-16).
	Step 2. Inspect for plugged filter.	If filter is plugged, clean filter.

Table 4-2. Troubleshooting Continued.

MALFUNCTION	TEST OR INSPECTION	CORRECTIVE ACTION
17. RIPPER WILL NOT RAISE	Step 1. Check for low oil level.	If low, add oil.
	Step 2. Check for oil pump failure.	If pump has failed, replace pump.
18. RIPPER WILL NOT LOWER	Inspect for low oil level.	Check and add oil. (see LO).
19. RIPPER WILL NOT STAY IN GROUND	Check for proper shank adjustment.	If shank is not properly adjusted, adjust shank (para 3-19).
20. TRACTOR HAS DIFFICULTY PULLING RIPPER	Ripper set too deep or too many shanks.	Adjust shank depth (para 3-19).
21. TRANSMISSION DOES NOT OPERATE IN ANY SPEED	Step 1. Check to see if oil level is low.	If oil level is low, add oil.
	Step 2. Inspect for leakage in external lines.	If leaks are discovered, check hoses, lines, fittings, and replace defective parts (para 4-54).
	Step 3. Inspect for oil pump or drive gear failure.	If drive gear failure is discovered, replace pump (para 4-53).

Section VII. RADIO INTERFERENCE SUPPRESSION

4-10. General Methods Used to Attain Proper Suppression

Essentially, suppression is attained by providing a low resistance path to ground for stray currents. The methods used include shielding the ignition and high frequency wires, grounding the frame with bonding straps, and using capacitors and resistors.

4-11. Interference Suppression Components

The primary suppression components are those whose primary function is to suppress radio interference. These components are illustrated on figure 4-2.

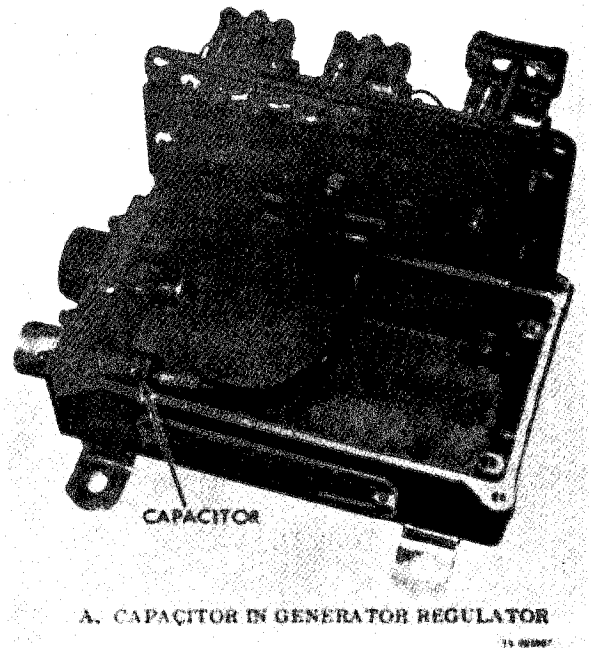

Figure 4-2. Radio interference suppression components (sheet 1 of 4).

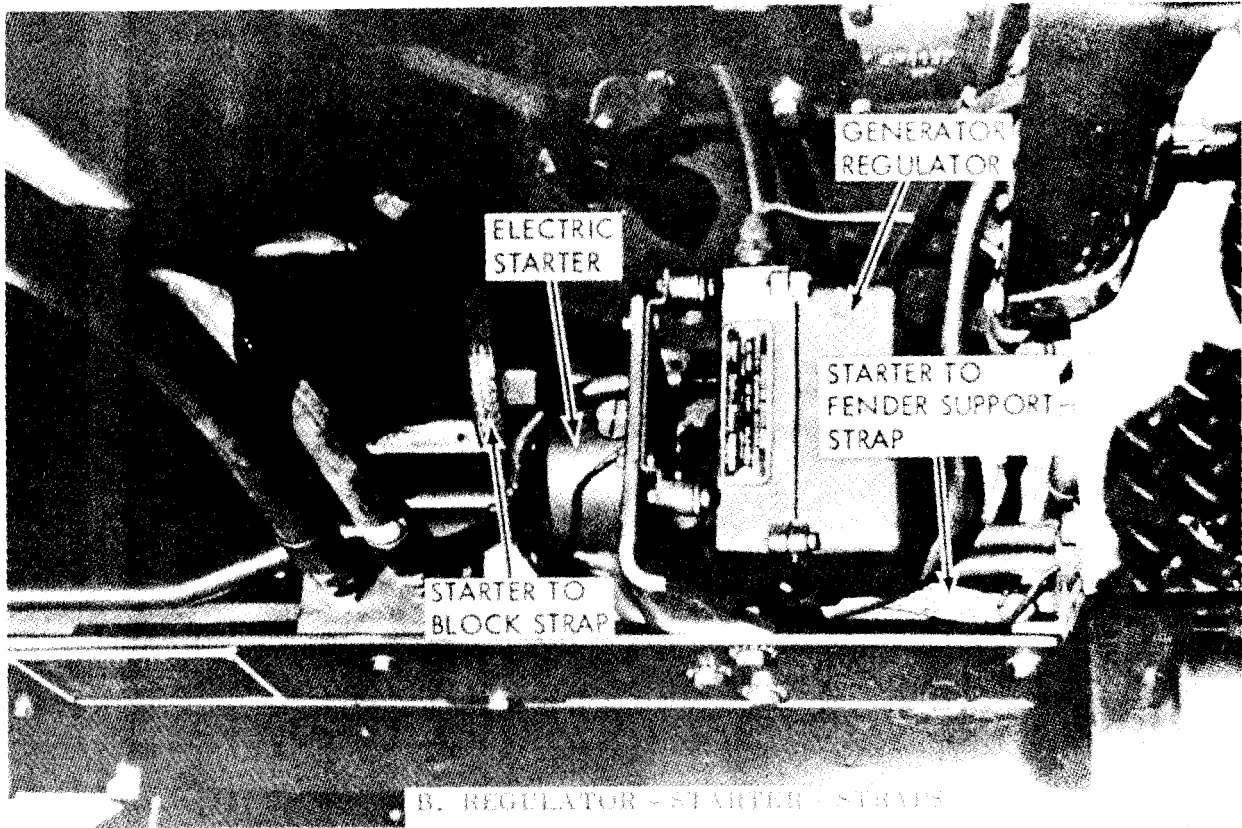

Figure 4-2. Radio interference suppression components (sheet 2 of 4).

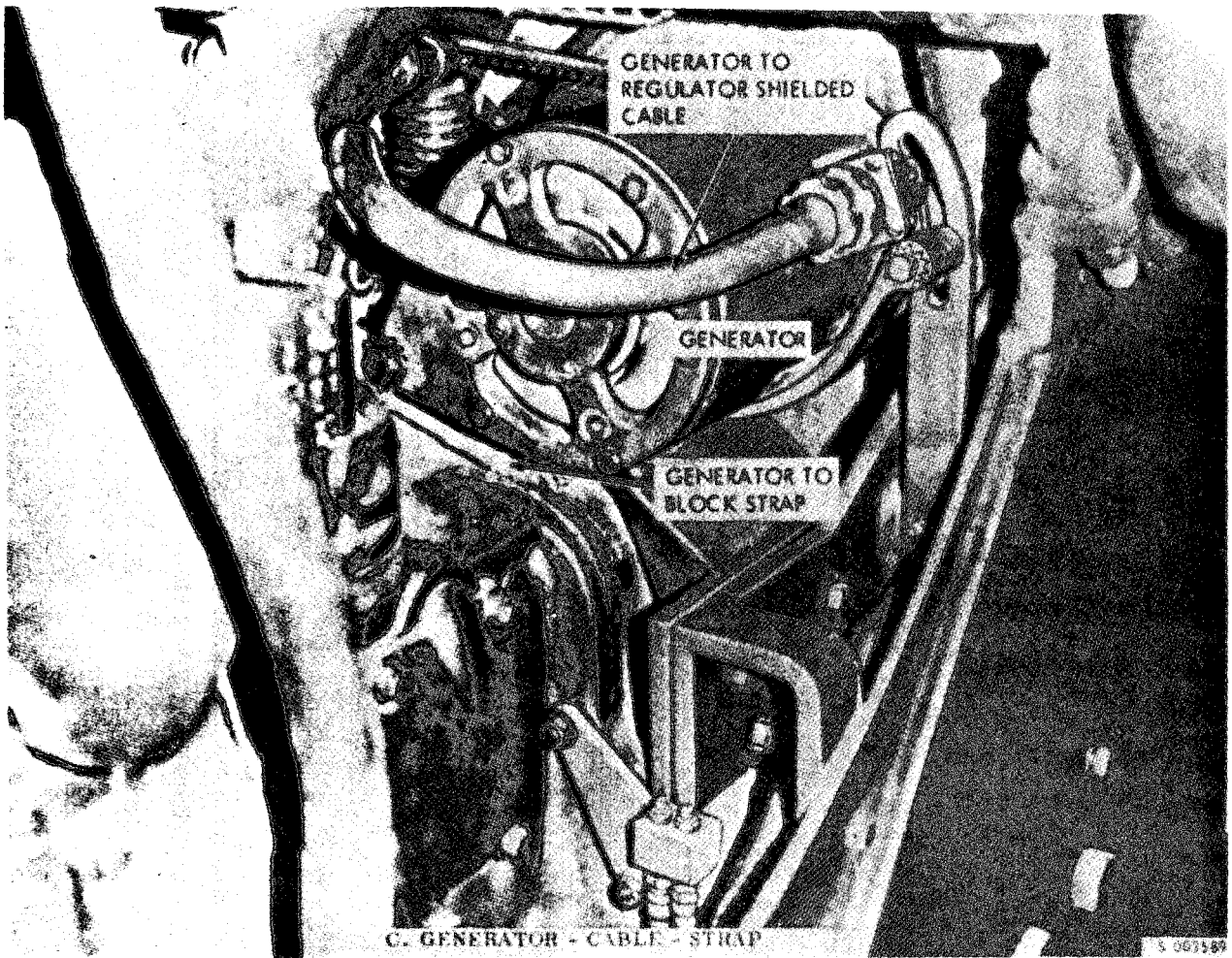

Figure 4-2. Radio interference suppression components (sheet 3 of 4).

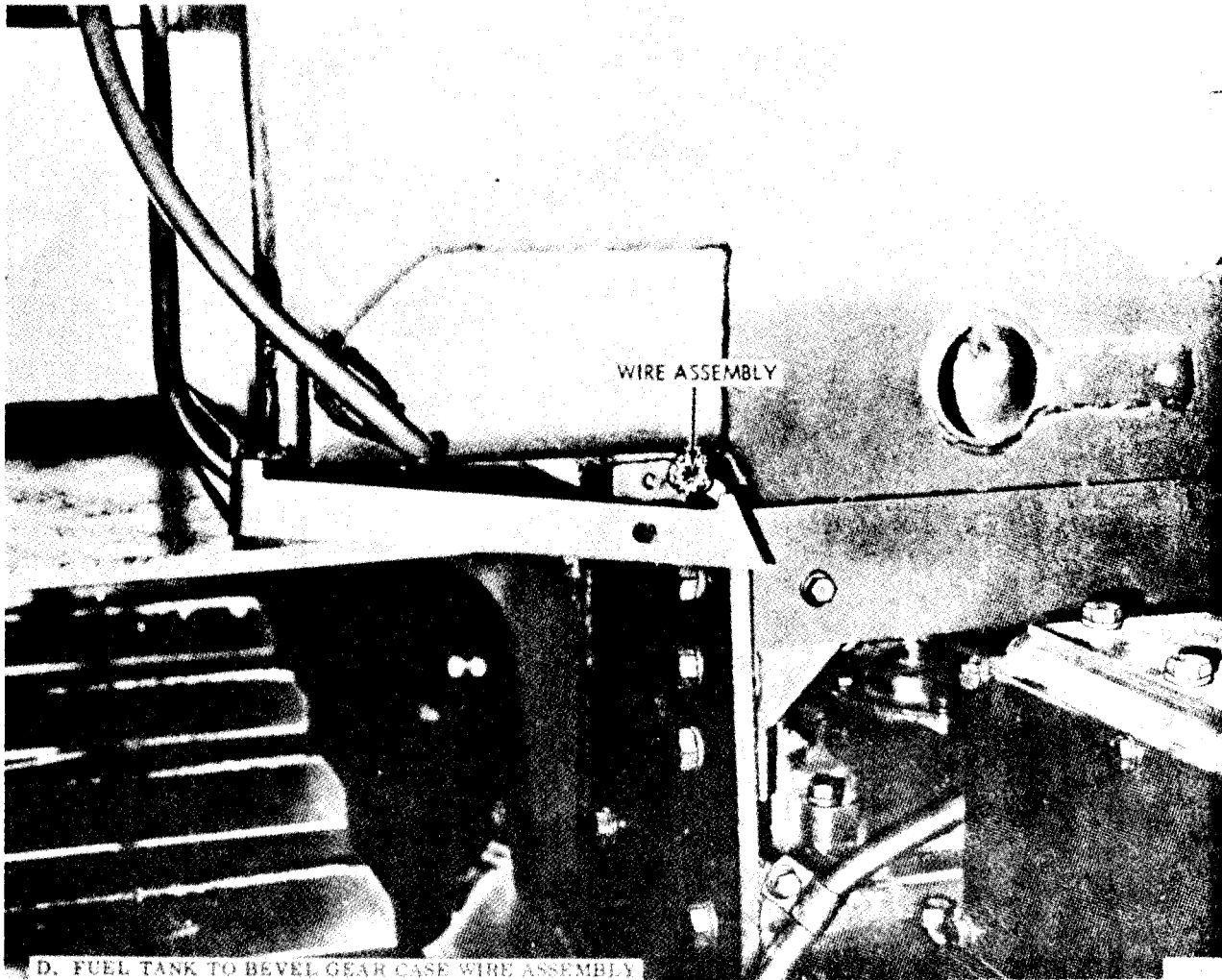

Figure 4-2. Radio interference suppression components (sheet 4 of 4).

**4-12. Replacement of Suppression Components**

a. The primary suppression components shown on figure 4-2 are replaced by removal of attaching hardware, except for the capacitor which requires removal of the regulator cover and disconnecting the lead.

**CAUTION**

**Do not pull on the cable or twist the braided shielding. Gently work the cable from side to side and free the rubber seal. Do not use sharp tools to install the seals.**

b. The secondary suppression components have radio suppression functions which are in-

cidental and, or, secondary to their primary function. They consist of external and internal tooth type lockwashers used to attach electrical components for better grounding.

**4-13. Testing of Radio Interference Suppression Components**

Test the capacitor for leaks and shorts on a capacitor tester. Replace defective capacitor. If test equipment is not available and interference is indicated, isolate cause of interference by trial-and-error method of replacing parts until the cause of interference is located and eliminated.

## Section VIII. ENGINE VALVE MECHANISM

**4-14. General**

*a.* The valves and the valve mechanism admit inlet air and release exhaust gases at precisely timed intervals during engine operation.

*b.* Properly adjusted valves will operate for many hours before they need to be reconditioned. Eventually, however, the valve faces and seats

may become pitted which ultimately allows compression pressure losses.

*c.* A compression release mechanism opens the inlet valve on each cylinder allowing the diesel engine to be easily cranked and positioned when repair work is necessary on the engine.

*d.* Release compression as shown in figure 4-3.



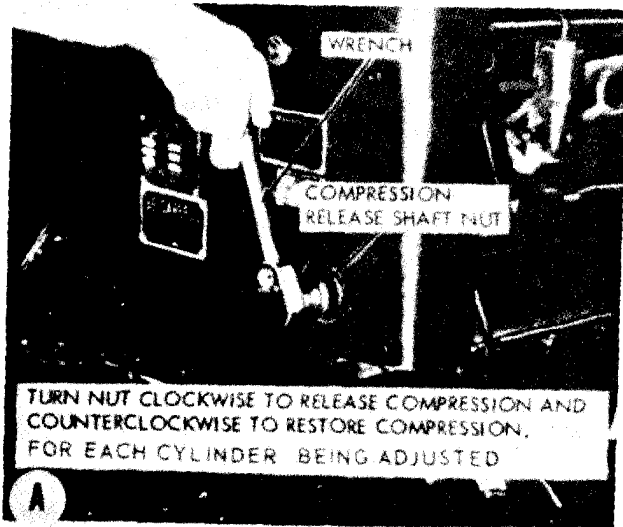

A. COMPRESSION RELEASE

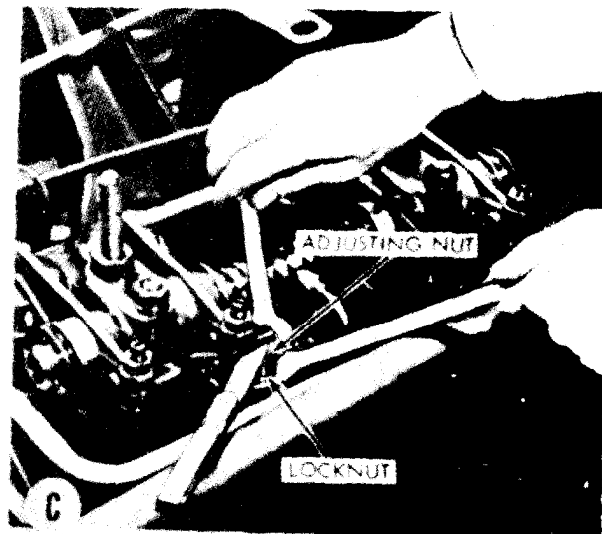

C. COMPRESSION RELEASE PUSHROD ADJUSTMENT

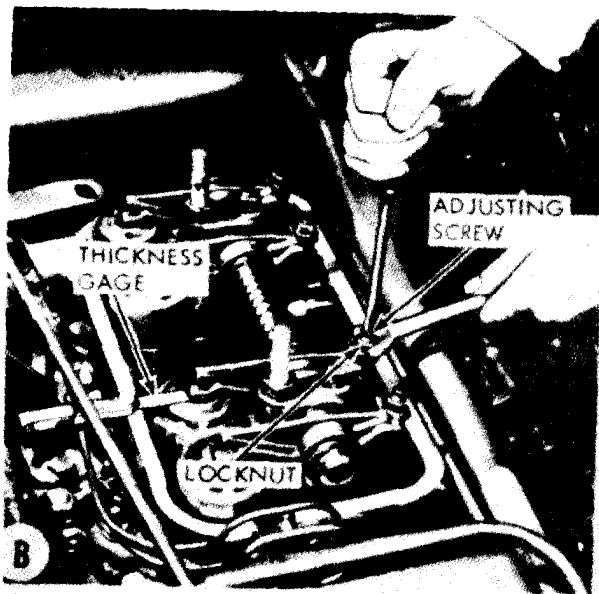

B. VALVE CLEARANCE ADJUSTMENT

- STEP 1. LOOSEN THE LOCK NUT AND TURN THE ADJUSTING SCREW TO ALLOW THE GAGE TO PASS BETWEEN TOP OF VALVE SLEEVE AND END OF VALVE ROCKER AT .016 INCH FOR INTAKE VALVE, AND .020 FOR EXHAUST VALVE
- STEP 2. TIGHTEN LOCK NUT AND CHECK ADJUSTMENT
- STEP 3. WITH ENGINE STOPPED, CHECK CLEARANCE BETWEEN UPPER END OF THE COMPRESSION RELEASE PUSH ROD AND THE END OF THE VALVE ROCKER.
- STEP 4. TO ADJUST, LOOSEN THE ADJUSTING SCREW LOCK NUT ON THE COMPRESSION RELEASE PUSH ROD AND TURN THE ADJUSTING NUT UNTIL THE CORRECT CLEARANCE IS .025 - .030 INCH.

TS 003591

Figure 4-3. Compression release and valve clearance adjustment.

#### 4-15. Valve Clearance Adjustment

a. Make the initial valve clearance adjustments after the first 100 to 125 service hours of operation. Thereafter, check and adjust if necessary after every 500-service hour operating interval.

b. Make the valve clearance adjustment while the engine is hot or before it has been stopped 20 minutes, after having run long enough to thoroughly warm up. If the adjustment is not completed during this 20-minute interval, start the engine and allow it to warm up again.

c. Turn the engine until the valve closes and the push rod is at its lowest point.

d. Adjust valves as illustrated in Section V. After valve clearance adjustment has been made,

check to see if the valves rotate. The rotating of valves decreases carbon build-up and uneven wear, thereby increasing the lift of the valves.

## Section IX. ENGINE LUBRICATION SYSTEM

### 4-16. General

a. Oil flow is illustrated in figures 4-4, 4-5, and 4-6. A pressure operated turbocharger lubrication valve, located in the oil filter base supplies the initial turbocharger lubrication upon starting. When starting the engine and until the system oil pressure reaches the normal operating range, the valve directs oil under pressure directly from the oil pump to the turbocharger bearings. When the oil in the system reaches normal operating pressure, filtered oil pressure forces the lube valve to move from its seat and filtered oil flows to the turbocharger bearings.

### b. Oil Pressure.

(1) When the engine is warm and running at rated speed, the gage should register in operating range. A lower pressure reading is normal at low idling speeds.

(2) If for any reason oil gage registers no pressure, stop engine immediately until difficulty can be determined and corrected.

(3) A small orifice in gage connection prevents rapid gage fluctuations. Check orifice for dirt in event gage becomes inoperative.

(4) If oil pressure gage indicates low or no oil pressure, refer to Table 3-2.

- 1 Oil tube from distribution manifold to rear rocker arm shaft (similar tube to the front rocker arm shaft)
- 2 Turbocharger oil supply line (return line on left side of engine)
- 3 Turbocharger vent line
- 4 Rear rocker arm shaft
- 5 Oil filter assembly
- 6 Fuel injection pump housing oil supply line
- 7 Oil line from block to filter base
- 8 Fuel injection pump housing oil return line
- 9 Oil distribution manifold
- 10 Rear scavenger suction bell
- 11 Drilled passage in crankshaft
- 12 Three section oil pump
- 13 Main suction bell
- 14 Drilled passage in connecting rod
- 15 Front scavenger suction bell

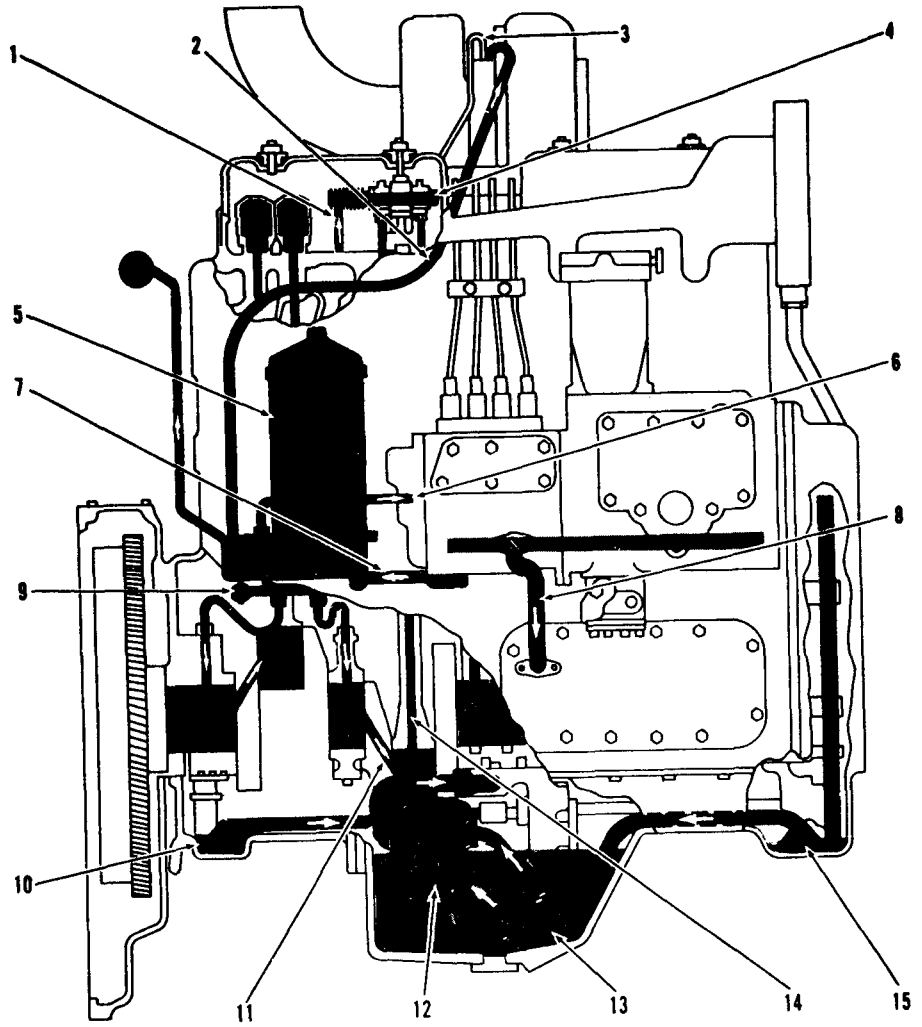

TS 003592

Figure 4-4. Engine lubricating oil flow.

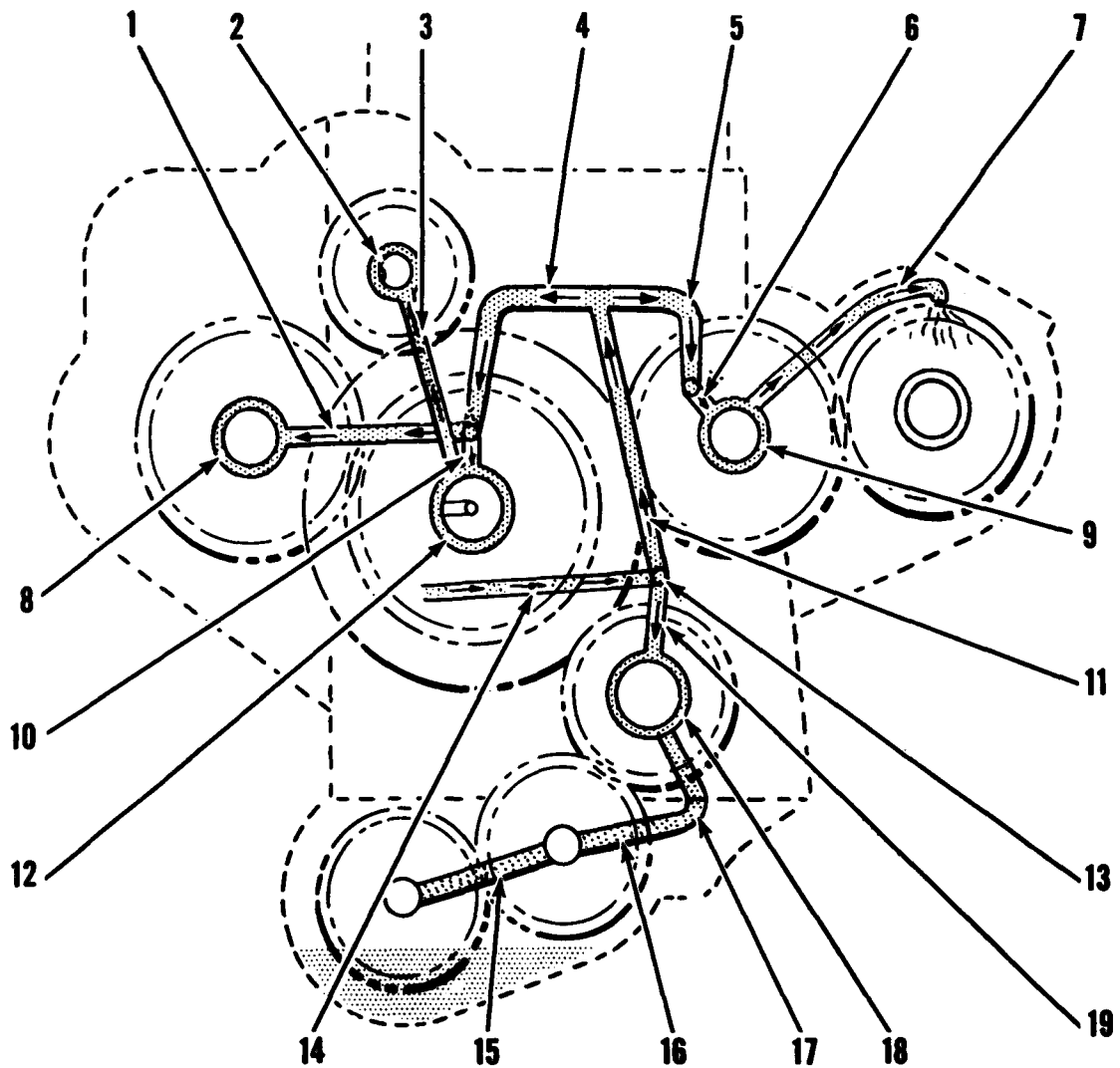

TS 003593

- |                                |                        |
|--------------------------------|------------------------|
| 1. Passage                     | 11. Tube               |
| 2. Rear power takeoff bearings | 12. Camshaft bearing   |
| 3. Passage                     | 13. Fitting            |
| 4. Tube                        | 14. Tube               |
| 5. Tube                        | 15. Tube               |
| 6. Passage                     | 16. Tube               |
| 7. Tube                        | 17. Passage            |
| 8. Accessory shaft bearing     | 18. Front main bearing |
| 9. Idler shaft bearing         | 19. Passage            |
| 10. Passage                    |                        |

Figure 4-5. Timing gear lubrication.

**4-17. Oil Filter and Base**

*a. General.* An oil filter bypass valve, oil cooler by-pass valve, and turbocharger lubrication valve, have been incorporated into the oil filter base. An external oil cooler bypass line is provided.

*b. Removal.*

- (1) Remove engine side guard.
- (2) Drain oil from filter base (fig 4-6).
- (3) Remove parts illustrated in figure 4-6.
- (4) Remove filter base.

*c. Disassembly.* Disassemble filter and base as illustrated in figure 4-7.

*d. Cleaning and Inspection.*

- (1) Clean all parts in an approved solvent and dry thoroughly.
- (2) Clean all lubrication oil passages with compressed air.
- (3) Inspect all parts for wear and damage.
- (4) Inspect sealing surfaces of bypass valve plungers and filter base.
- (5) Inspect turbocharger lubrication valve.

(6) Replace all damaged gaskets.

e. Reassembly. Reassemble in reverse order of disassembly. Use a new plug when assembling the filter bypass valve.

f. Installation. Install in reverse order of removal.

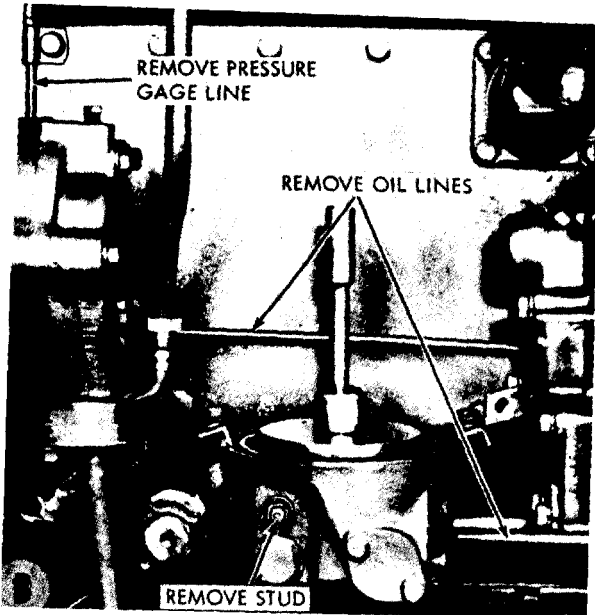
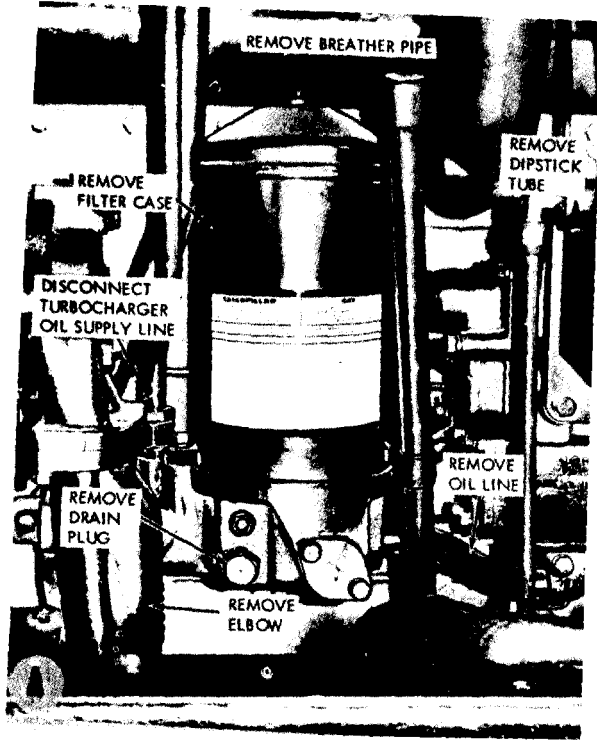

KEY to figure 4-7.

1. Plug
2. Retainer
3. Turbocharger lubrication valve
4. Spring
5. Filter bypass valve
6. Spring
7. Cooler bypass valve
8. Spring
9. Cover
10. Clip
11. Retainer
12. Spring
13. Bolt
14. Packing
15. Washer

TS 003594

Figure 4-6. Engine oil filter and base removal.

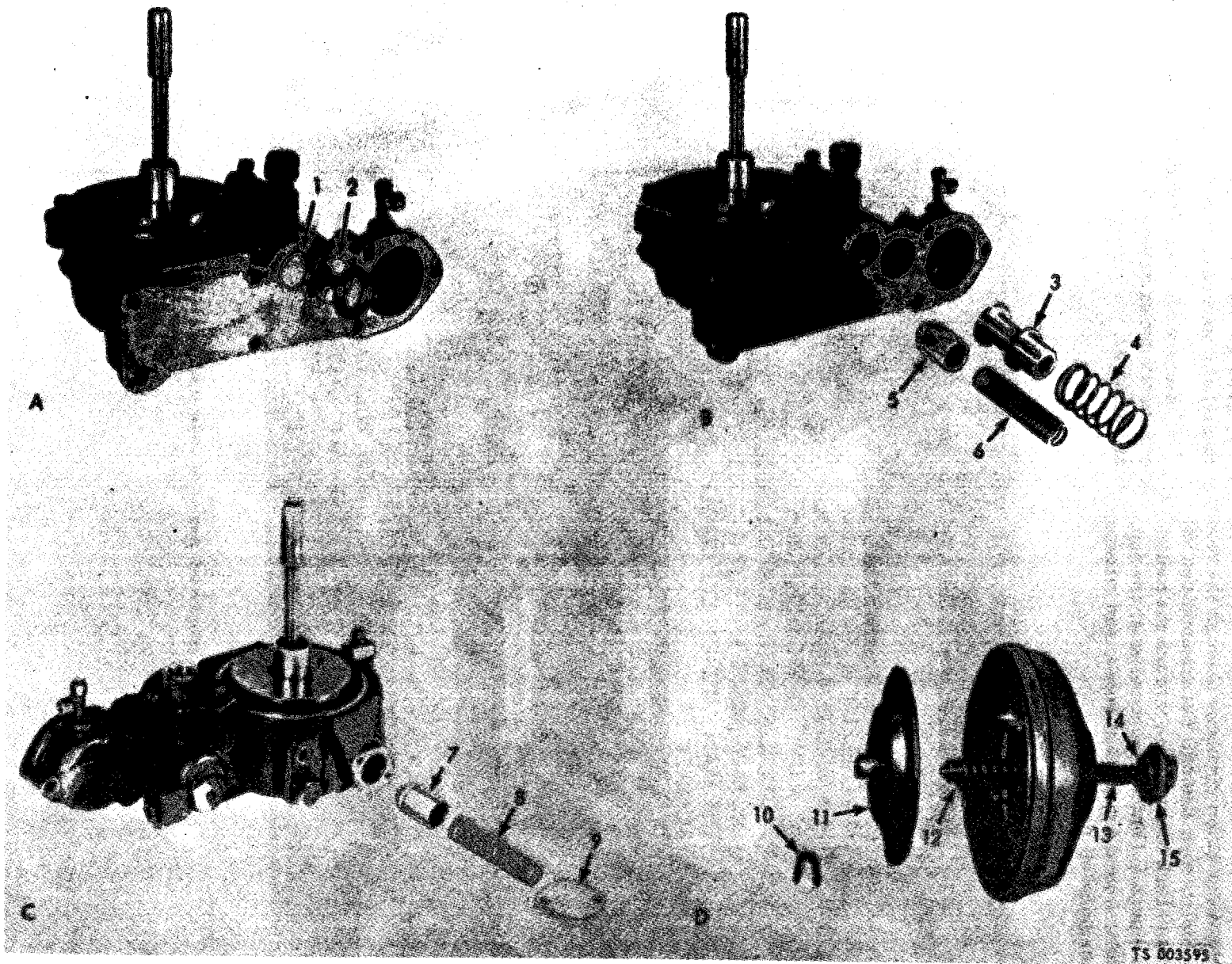

Figure 4-7. Engine oil filter and base disassembly.

### 4-18. Oil Cooler

*a. General.* The engine oil cooler is mounted on the left side of the engine. A portion of the coolant from the water pump circulates through the core of the cooler, then through the transmission oil cooler, and back to the engine through the coolant return line pipe. Oil enters the cooler at the top, circulates around the coolant tubes, and returns to the engine oil pan.

*b. Removal.* Refer to figure 4-8 and remove oil cooler.

*c. Disassembly and Cleaning.* Disassemble and clean the oil cooler as illustrated in figure 4-9.

*d. Reassembly and Installation.* Reassemble and install cooler in reverse order of disassembly and removal.

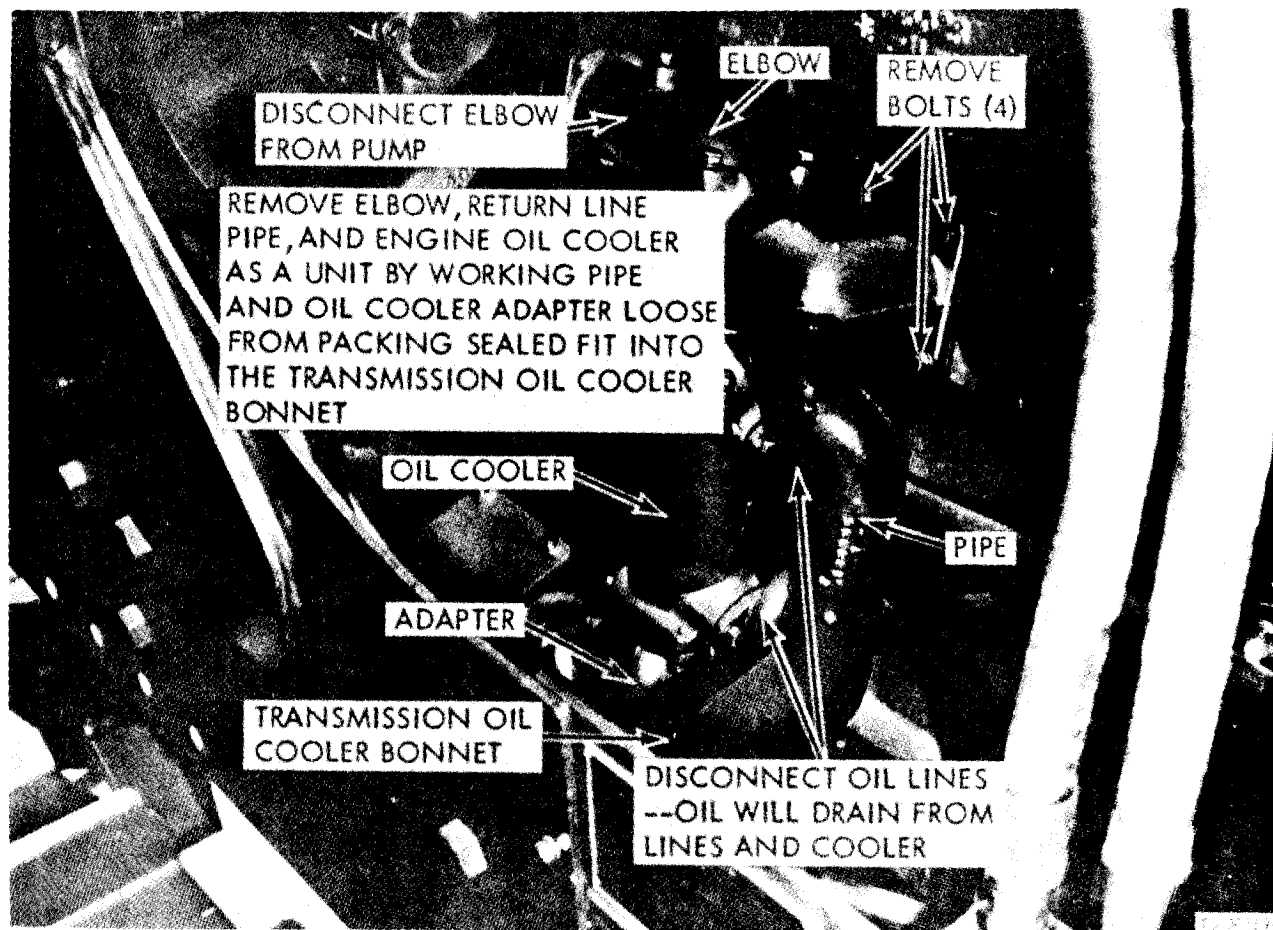

Figure 4-8. Engine oil cooler removal.

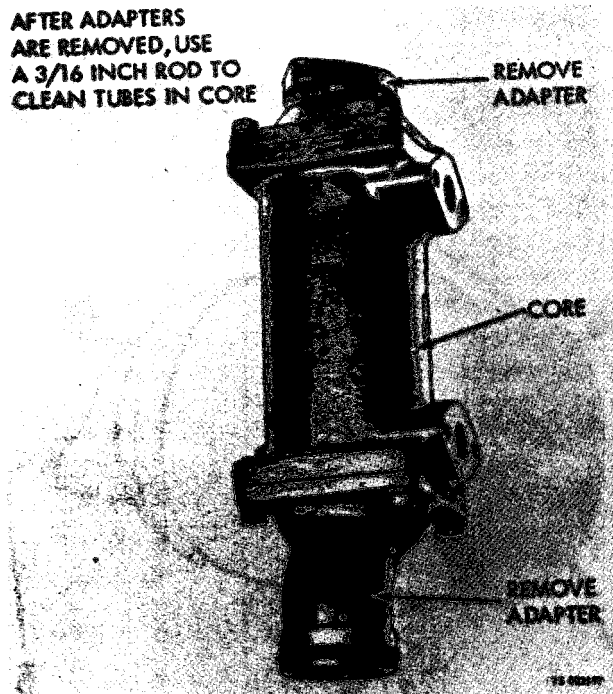

Figure 4-9. Engine oil cooler disassembly and cleaning.

#### 4-19. Breather and Oil Filter

a. *Removal.* Remove breather and oil filter as illustrated in figure 4-10.

b. *Disassembly and Cleaning.*

(1) Disassemble breather as illustrated in figure 4-11. Breather has an element which cannot be removed. This element, which is similar to element (3) can be cleaned by washing entire breather.

(2) Disassemble oil filler cover assembly as shown in figure 4-12. Clean all parts in an approved solvent. Inspect seal ring (4), gasket, and plate inside cover assembly. Replace any defective parts.

c. *Reassembly and Installation.* Reassemble breather in reverse order of disassembly. Install in reverse order of removal.

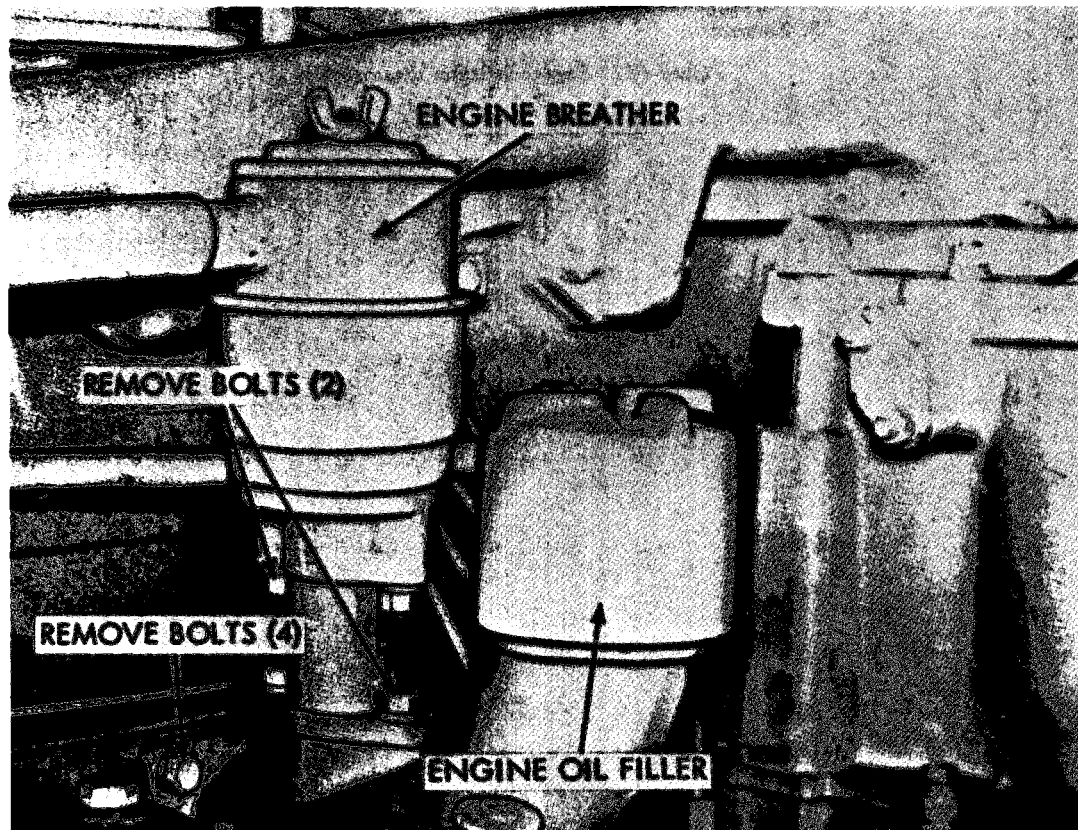

TS 003598

Figure 4-10. Engine breather and oil filter removal.



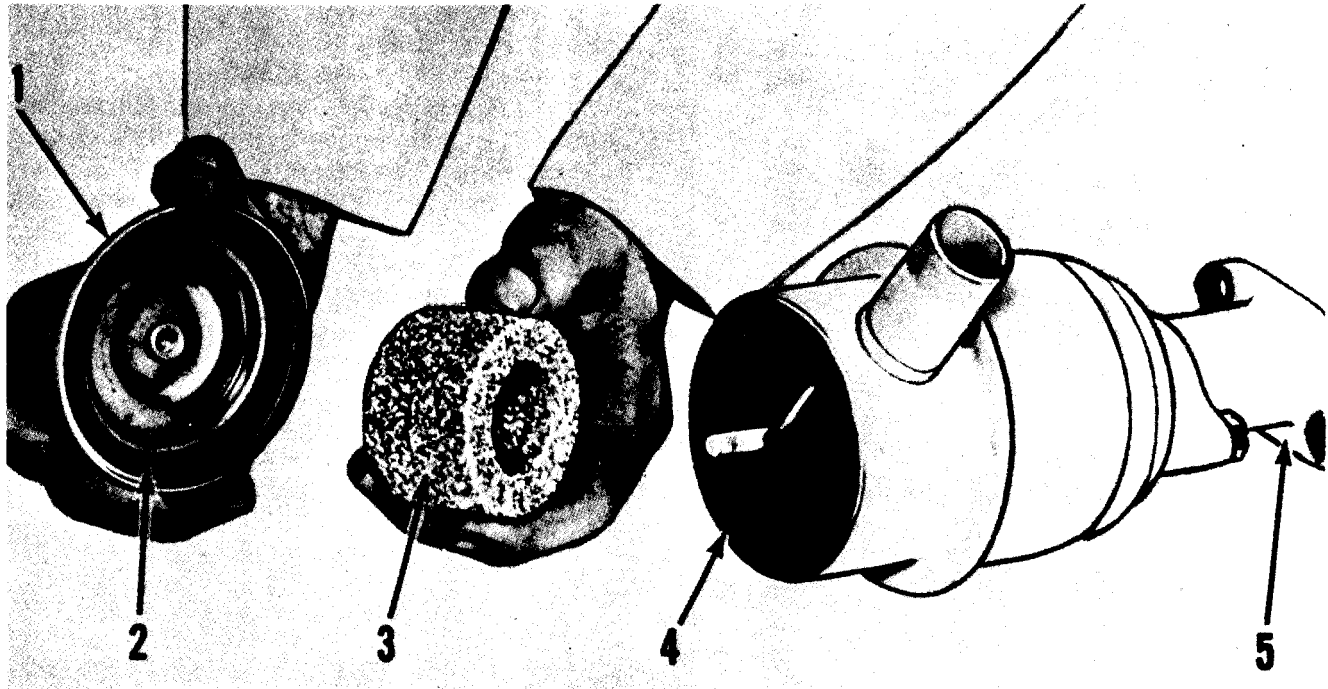

TS 003599

- 1. Cover assembly
- 2. Gasket
- 3. Element
- 4. Breather
- 5. Base

*Figure 4-11. Engine breather disassembly.*

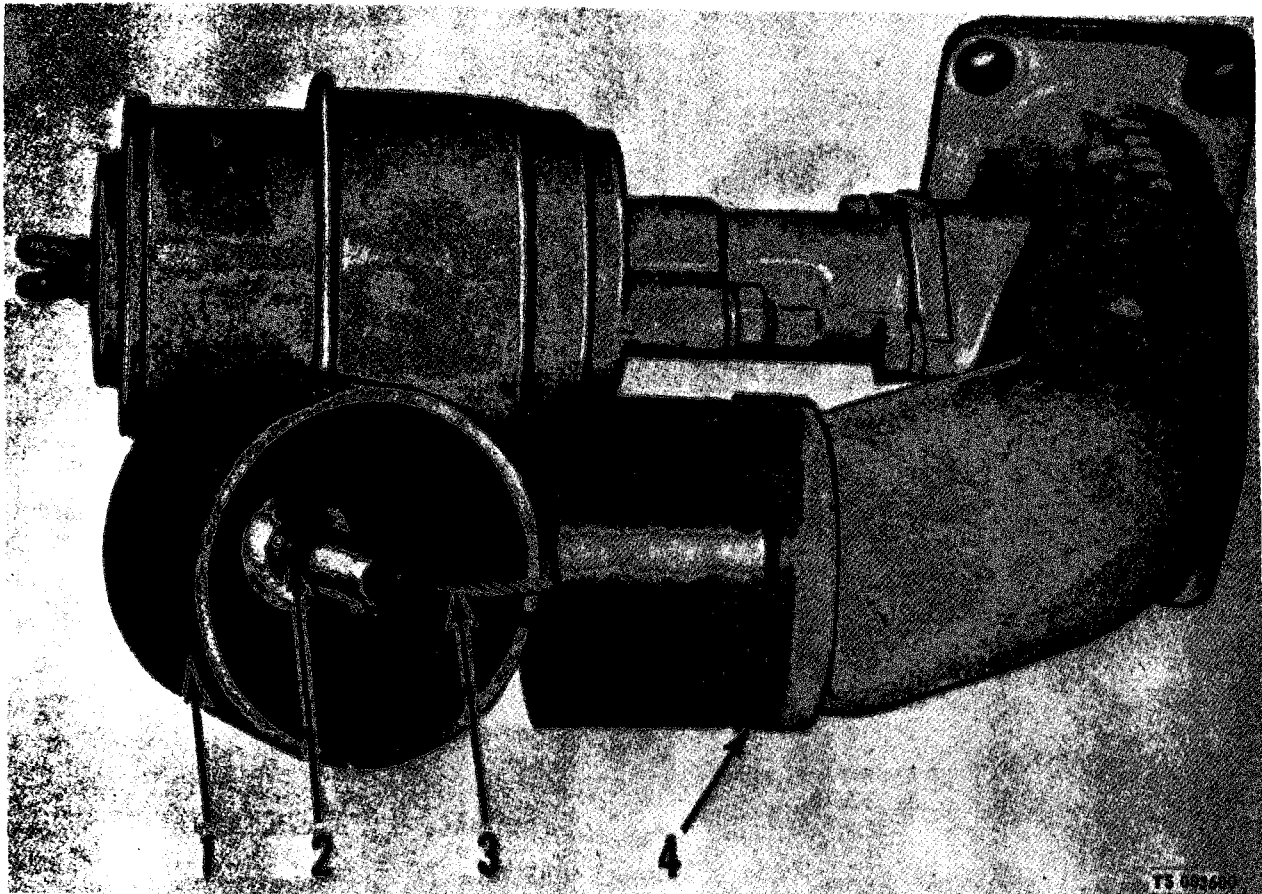

1. Cover assembly  
2. Cotter pin

3. Cable assembly  
4. Seal ring

Figure 4-12. Oil filler cover disassembly.

#### 4-20. Turbocharger Oil Lines

*a. General.* The turbocharger is supplied with oil under pressure through a line from the oil filter base to the turbocharger (A, fig. 4-13). Oil is returned to the crankcase through a line located on the opposite side of the engine (B, fig. 4.13).

*b. Removal and Installation.* Both lines are external and are easily removed or installed by

**disconnecting or connecting both ends.**

*c. Cleaning and Inspection.*

(1) Clean lines and fittings with an approved solvent and/or compressed air.

(2) Inspect lines and fittings for damage or defects.

(3) Replace defective parts.

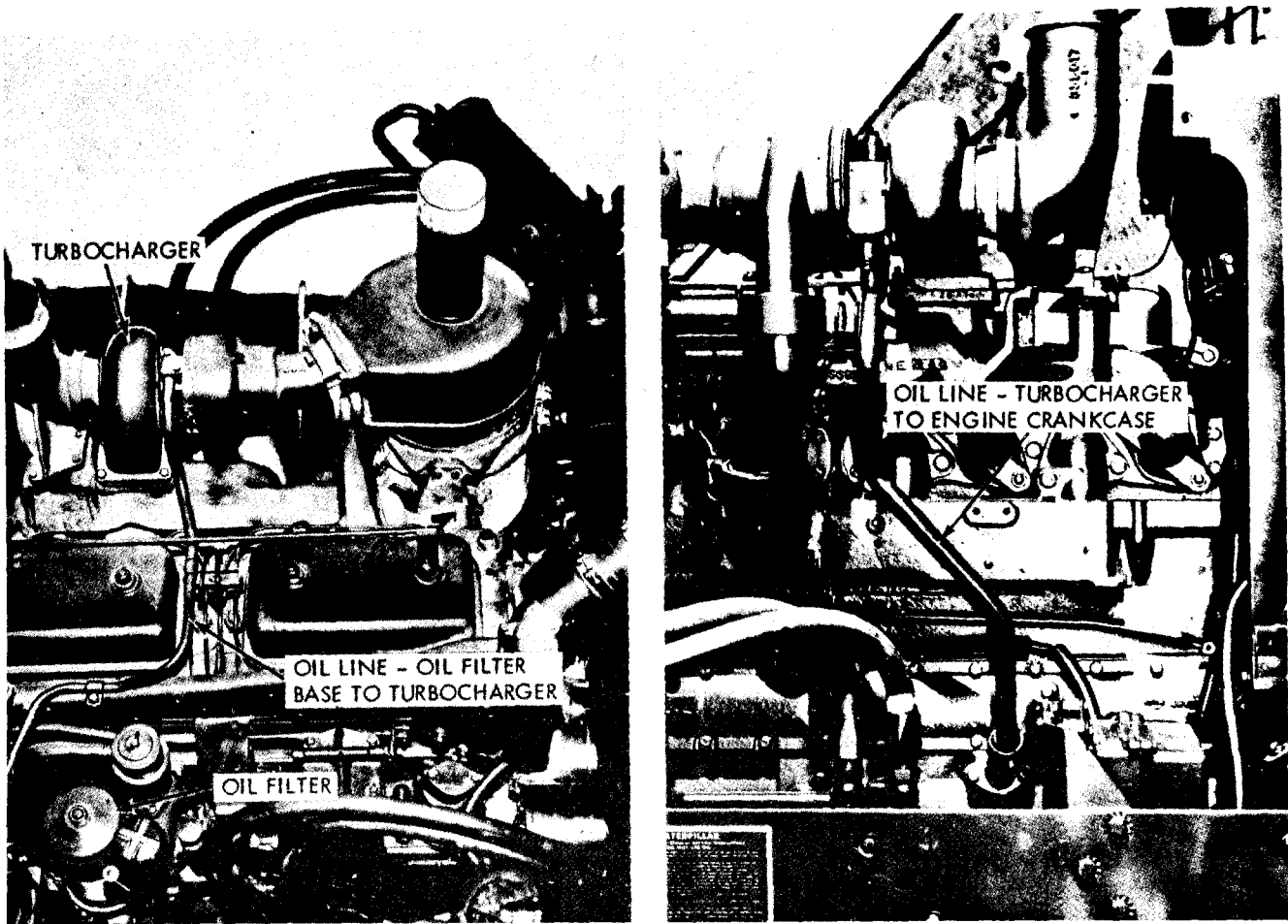

TS 003601

Figure 4-13. Turbocharger oil lines.

## Section X. CONTROLS AND INSTRUMENTS

### 4-21. Governor Controls

*a. Removal and Installation.* Refer to figure 4-14 to remove and install governor control parts as required.

### *b. Cleaning and Inspection.*

- (1) Clean all parts with an approved solvent and dry thoroughly.
- (2) Inspect parts for breaks, damage, or wear.
- (3) Replace worn or defective parts.

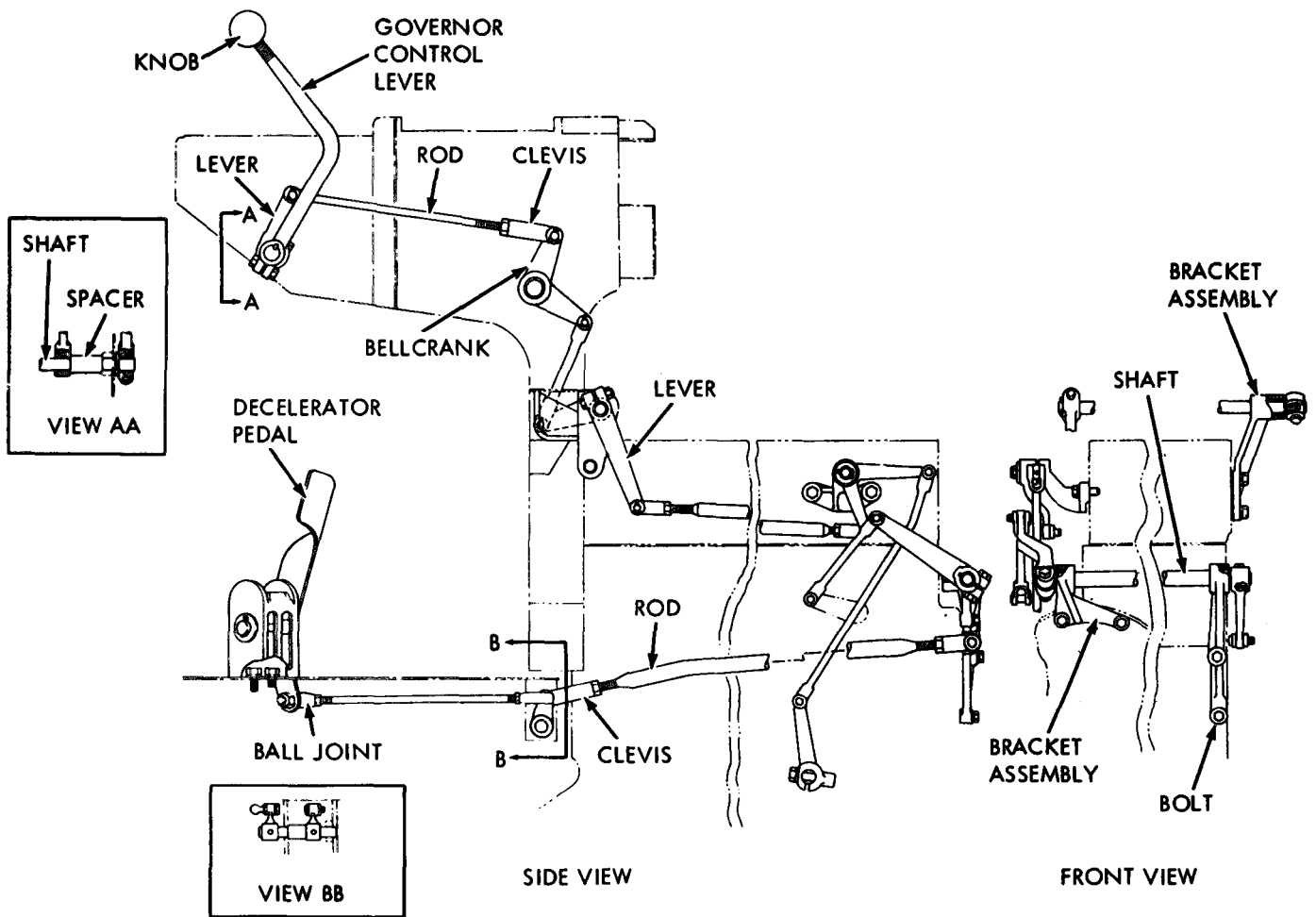

TS 003602

Figure 4-14. Governor and decelerator controls.

#### 4-22. Gages

*a. General.* Four gages and the ammeter are mounted on the instrument panel. The gages are, the engine oil pressure, transmission oil pressure, water temperature, and torque converter temperature gages. The fuel pressure gage is mounted on the fuel filter housing.

*b. Removal and Installation.* Refer to figure 4-15 to remove and install the gages, lines, fittings, and tubing as required. To remove or install the

ammeter, simply remove or install the attaching hardware and tag the electrical leads. The ammeter is illustrated in figure 2-1.

#### *c. Cleaning and Inspection.*

- (1) Wipe gages and ammeter clean using an approved solvent.
- (2) Inspect tubing or wiring for damage or defects.
- (3) Replace defective or damaged parts.

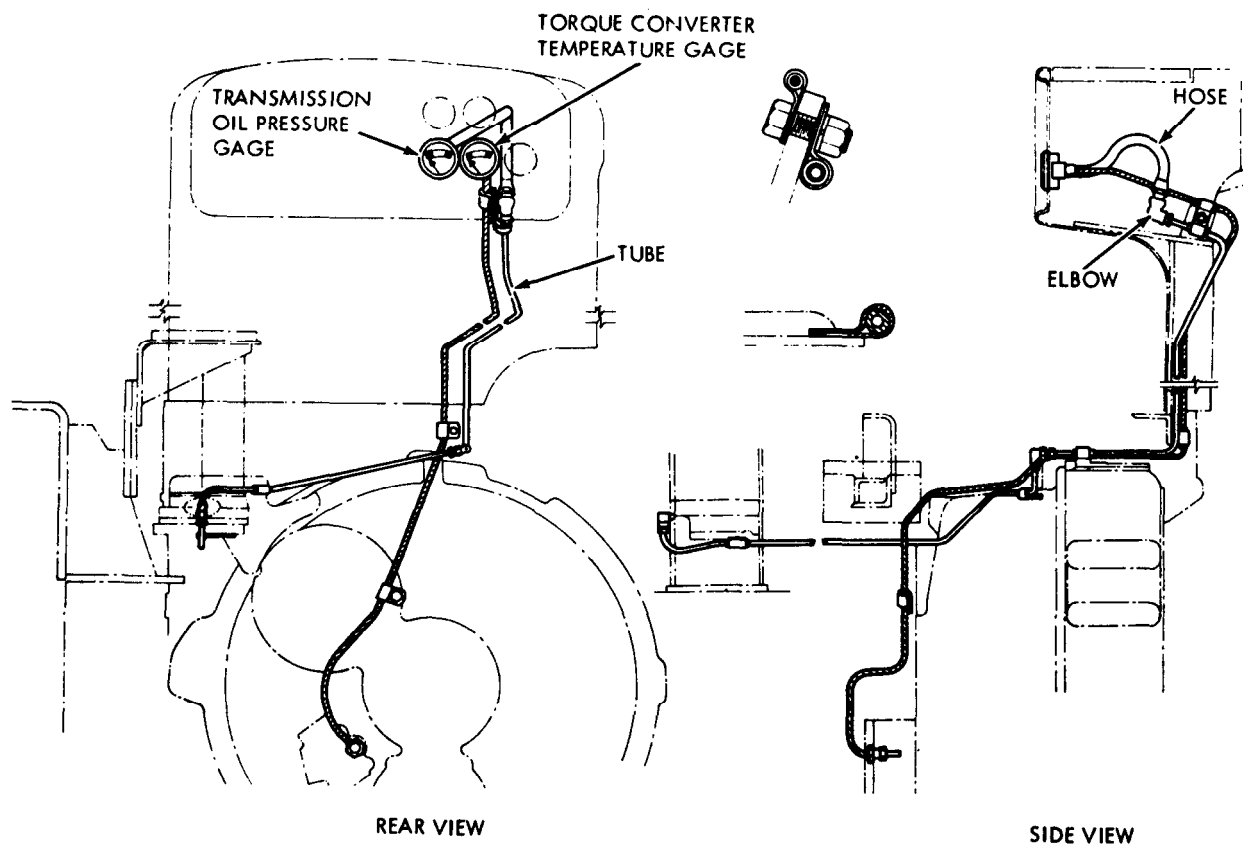

TS 003603

Figure 4-15. Gages.

#### 4-23. Time Totalizing Meter (Hourmeter)

##### a. General.

(1) The time totalizing meter is mounted on the side of the governor housing. The meter is geared to the engine and when the crankshaft turns as many revolutions as are made in an hour at average operating speeds on an average job application, the dial advances one number. There are some applications that will result in either a lower or higher than normal average engine speed. Under this condition, the advance in the

meter reading will differ from the number of clock hours of operation.

(2) The drive shaft of the meter has the end grooved so a tachometer can be installed after cover has been removed. Engine speed can be checked at this point using a tachometer. The drive shaft rotates at one-half engine speed.

**b. Removal and Installation.** Refer to figure 3-3 to remove and install the time totalizing meter.

**c. Cleaning and Inspection.** Clean with an approved solvent. Inspect for wear and damage.



TS 003604

*Figure 4-16. Time totalizing meter, removal and installation.*

## Section XI. FUEL SYSTEM

### 4-24. General

*a. Fuel flows from the diesel fuel tank through the primary fuel filter to the fuel transfer pump. The primary fuel filter removes any foreign material that might be in the fuel before it enters the fuel transfer pump. The fuel transfer pump supplies fuel under pressure to the fuel filter housing where the fuel is again filtered. From here*

*fuel is supplied to the fuel pump manifold for the individual fuel injection pumps. The fuel injection pumps meter and force fuel through the fuel injection lines and the fuel injection valves into the precombustion chamber where it is ignited and passed into the main combustion chamber or cylinder. Figure 4-17 illustrates the flow of fuel.*

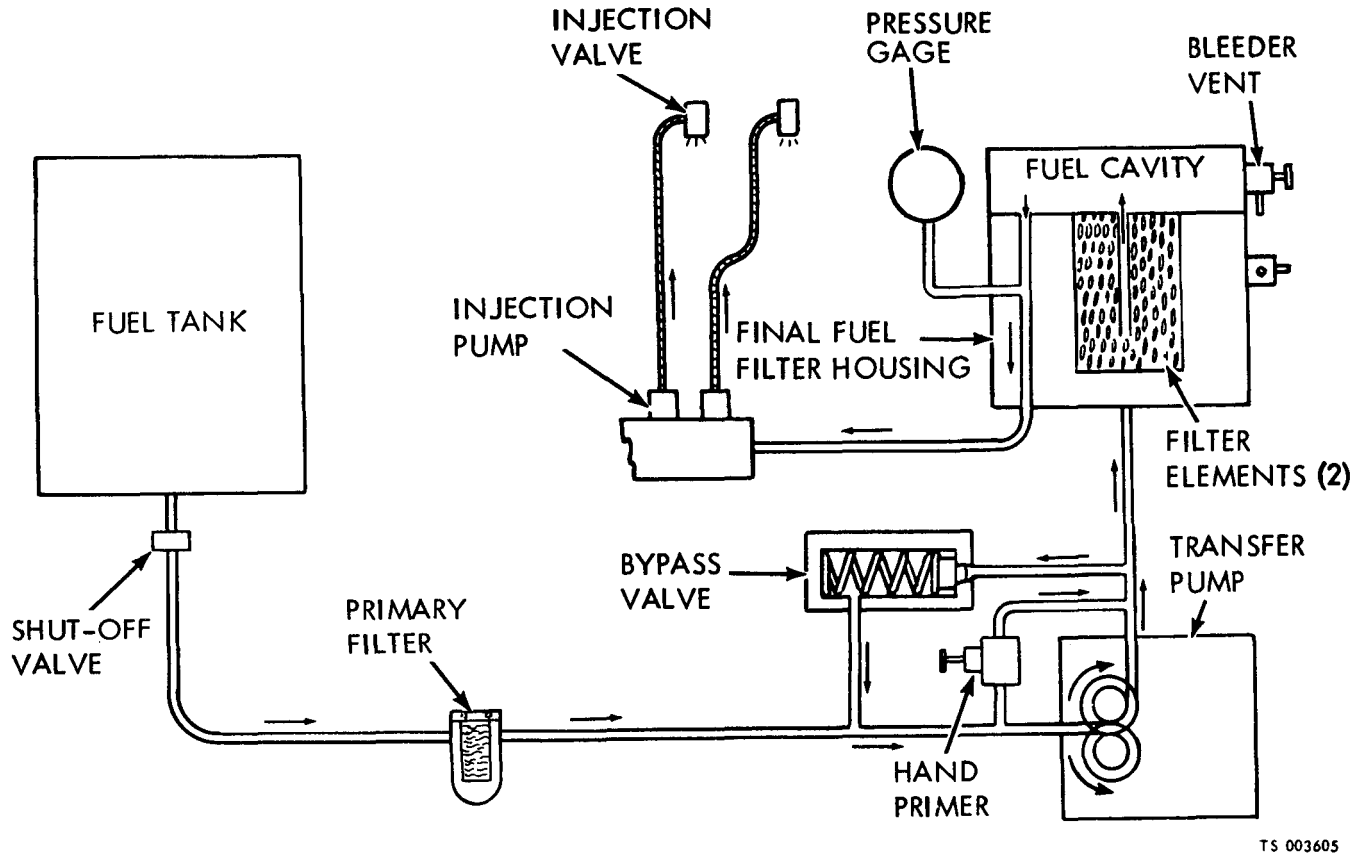

TS 003605

Figure 4-17. Flow of fuel.

b. As the metallic filter element in the primary filter, or the resin impregnated cellulose material type fuel filter elements in the fuel filter housing, gradually become clogged with foreign material, the fuel pressure gage indicator will work back from its original position in the NORMAL range, to the CAUTION range and later into the OUT (red) range. When the indicator reads in the OUT range, remove and wash the metallic element (fig. 3-5). If the indicator still reads in the OUT range, replace the resin impregnated cellulose material type fuel filter elements (fig. 3-7).

c. When improper fuel injection is affecting the diesel engine operation, make a systematic check to determine the cause. The most likely cause is dirt or water in the fuel. Drain the sediment from the diesel fuel tank and drain the fuel filter housing (figs. 3-3 and 3-6). Prime the fuel system until clean fuel passes through the vents on the fuel injection pumps. If the fuel system is air bound, priming the system will overcome the difficulty (fig. 3-8).

d. When the engine is running irregularly, and smoking, a fuel injection valve may not be spraying the fuel properly.

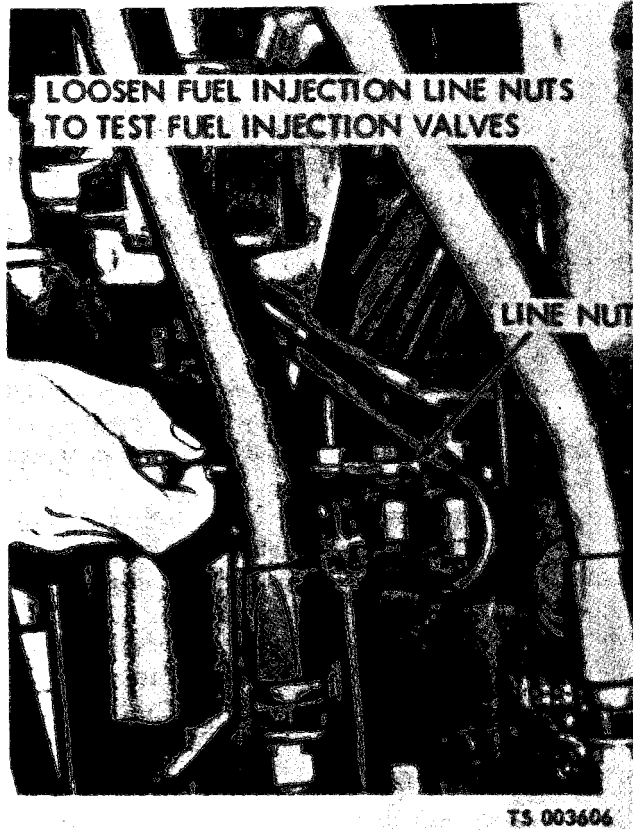

Figure 4-18. Testing fuel injection valve.

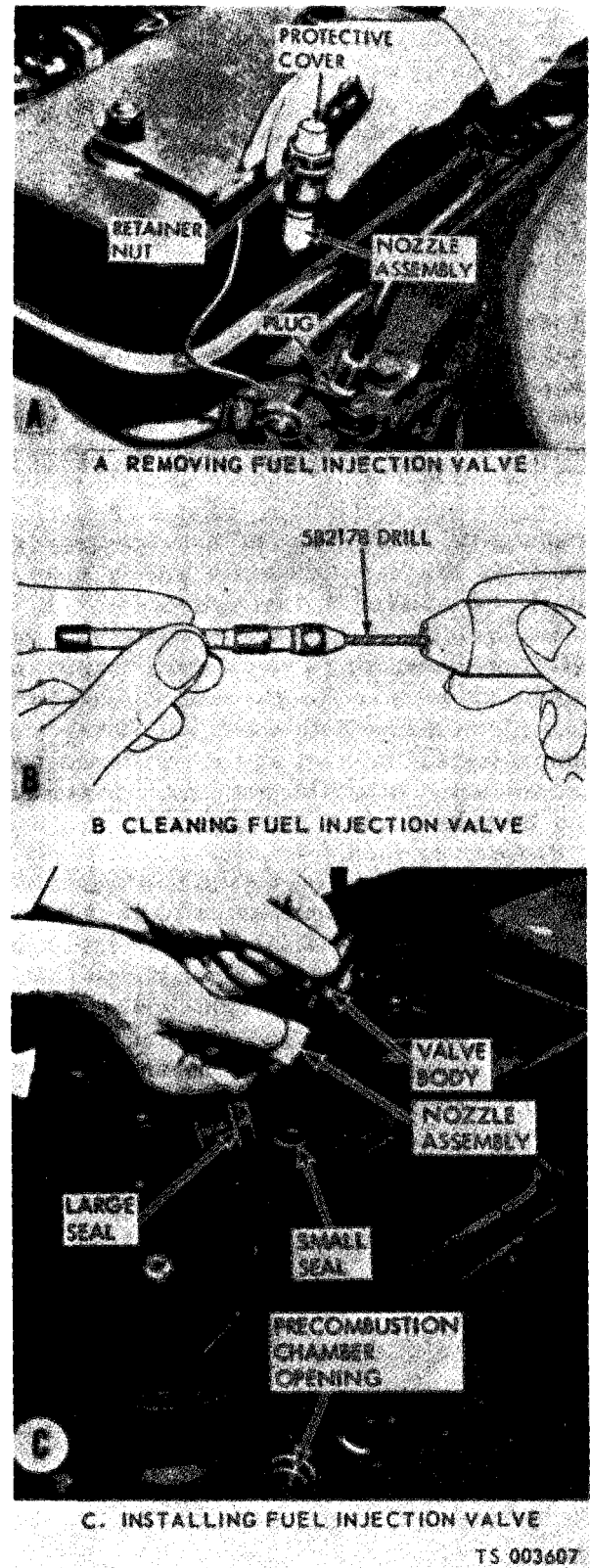

Figure 4-19. Servicing fuel injection valves.



#### 4-25. Fuel Injection Valves

*a. General.* The function of the fuel injection valves is to inject and atomize the fuel from the fuel injection pumps into the precombustion chambers. Irregular engine operation and smoking may be caused by an improperly operating injection valve. The fuel injection valves are installed in the precombustion chambers.

*b. Testing Fuel Injection Valves (fig. 4-18).* Whenever an engine performs in such a manner that a fuel injection valve is suspected of causing trouble, test injection valves. To test, loosen the fuel injection line nuts at the fuel injection pumps, one at a time, while the engine is running. When a nut is loosened and the exhaust smoking is completely or partially eliminated, and the irregularity in running is not affected, this identifies the defective valve and a new one should be installed in that cylinder.

*c. Removing Fuel Injection Valves (A, fig 4-19).* Before removing a valve, clean the dirt from around the valve and connections. Disconnect the fuel injection line from the injection valve and pump. Install the plug and cover. Remove the valve retainer nut and lift out the nozzle assembly and body as a unit.

*d. Cleaning Fuel Injection Valves (B, fig. 4-19).* Operation of the engine will be affected if the orifice in the nozzle becomes partially filled with carbon. To correct this, remove the nozzle assembly from the valve body and clean the fuel discharge hole using the 5B2178 drill and a chuck which are part of the 5B1401 cleaning tool group. If after cleaning, the valve does not operate properly, the nozzle should be checked for leakage.

#### CAUTION

**Do not attempt to clean the carbon from**

**the end of the injection nozzle with a wire brush or wheel. The only maintenance required on the injection nozzle is to clean the fuel discharge hole using the correct size drill as indicated.**

*e. Installing Fuel Injection Valves ( C, fig. 4-19).* Before installation of a fuel injection valve, be sure the wrench is clean. Proceed as follows:

(1) Screw valve body into nozzle assembly only finger tight.

(2) Insert nozzle assembly and valve body as a unit into precombustion chamber opening. Turn body in a clockwise direction and at same time press down to assure alignment of serrations.

(3) Install a new large seal on retainer nut. A light coating of lubricant on seal will permit it to seat properly.

(4) Tighten retainer nut to prevent leaks between nozzle assembly and nozzle assembly seats. A torque of 100 to 110 pounds feet is adequate to tighten retainer nuts.

(5) place a new small seal over threads on top of valve body and on retainer nut.

(6) Connect fuel injection line and tighten nut.

#### 4-26. Fuel Injection Pumps

*a. General.* Each pump (fig. 4-20), measures the amount of fuel to be injected into its respective cylinder and delivers it to the fuel injection valve. The injection pump plunger is lifted by a cam and always makes a full stroke. The amount of fuel pumped per stroke can be varied by turning the plunger in the barrel. The plunger is turned by the governor action through the rack which meshes with the gear segment on the bottom of the plunger.

#### NOTE

If more than one pump requires replacement, refer to direct support maintenance.

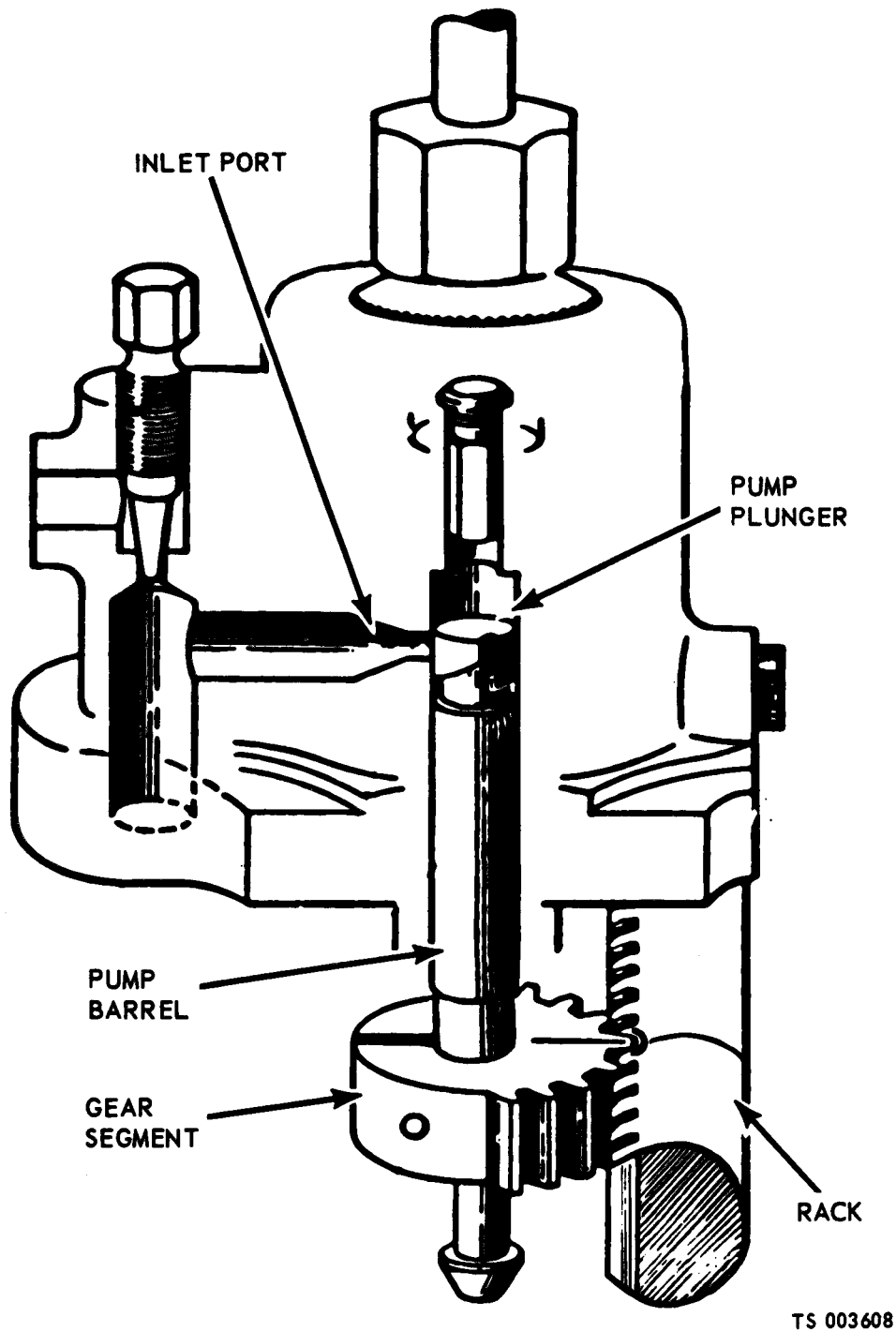

TS 003608

Figure 4-20. Fuel injection pump.

*b. Removing Fuel Injection Pumps* (Fig. 4-21).

(1) Remove fuel priming pump (fig. 4-22), primary filter (fig. 4-26), lines and fittings (fig. 4-24).

(2) Every precaution must be taken to prevent dirt from getting into fuel injection

pumps or housing. Clean top of housing and around inspection plate before removing plate. When fuel pumps are removed, pump plungers must not be taken from barrels as any dust or dirt will scratch these finely finished parts.

(3) Remove fuel injection lines from pumps and immediately cap and plug openings with

covers and plugs provided. Remove inspection plate.

(4) Remove bolts and clamps that hold fuel injection pump to housing and lift pump straight up only enough to clear dowel. Insert a finger through inspection hole to hold plunger and keep it from dropping out. Shift pump to one side so end on pump plunger will free itself from slot in lifter, then remove pump. Place ferrule cap seal and stopper, over fuel outlet of pump housing and m inlet of pump to keep out dirt.

(5) Should plunger accidentally be removed from pump barrel, take every precaution to avoid nicking or scratching it since the slightest rough spot will cause undue wear in barrel and shorten life of pump. Plunger should be rinsed in clean fuel before putting it back in barrel. Be sure the plunger is replaced in barrel from which it was removed. Each fuel injection pump assembly (plunger and barrel) is machined as a unit and finished to such exact limits that it must be used, removed, and replaced as a unit.

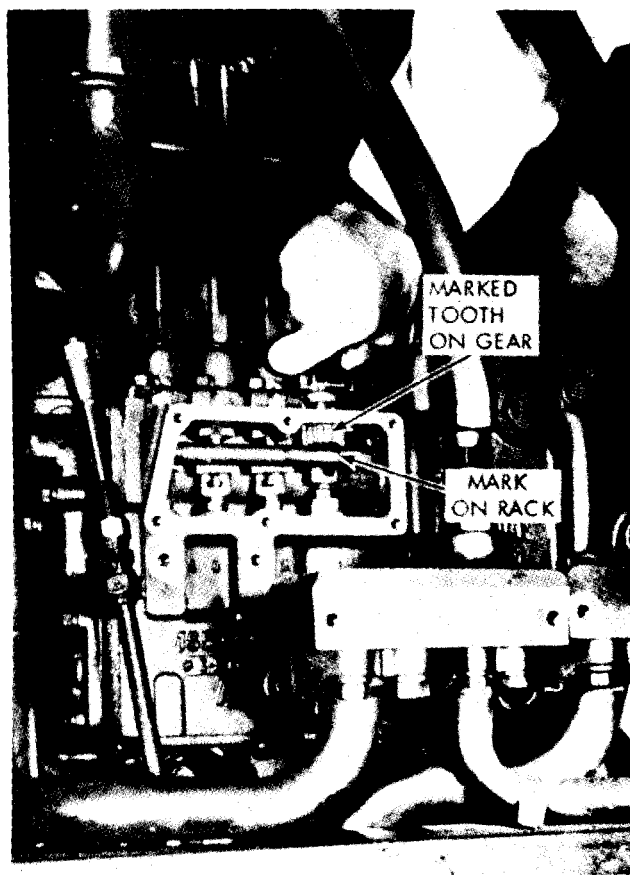
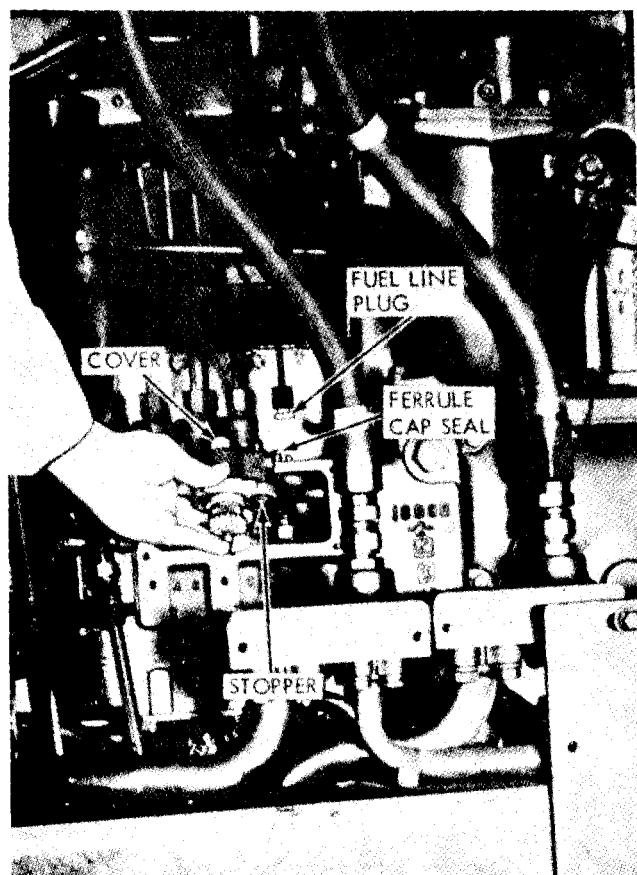

TS 003609

Figure 4-21. Fuel injection pumps, removal and installation.

*c. Installing Fuel Injection Pumps.* The pumps have a seal under the machined surface, around the large diameter of the pump. This seal must be properly positioned when the pump is being installed. There must also be a seal around the fuel outlet ferrule on the fuel pump housing. If either seal is damaged, replace it. Remove the ferrule cap seal and the stopper, and lower the

pump and plunger into the housing. Line up the marked tooth of the injection pump gear with the mark on the rack. Slide the end of the plunger into the slot in the lifter. Lower the pump on the dowel and fasten it in place. Remove the fuel line plug and the cap and connect the fuel line to the injection pump.

#### 4-27. Fuel Primer

a. *General.* This is a hand operated priming pump mounted on the right side of the engine near the fuel injection pump housing. The fuel

primer is used only to force air from the fuel system as described in paragraph 3-8.

b. *Removal and Installation.* Refer 4-22 to remove or install the fuel primer.

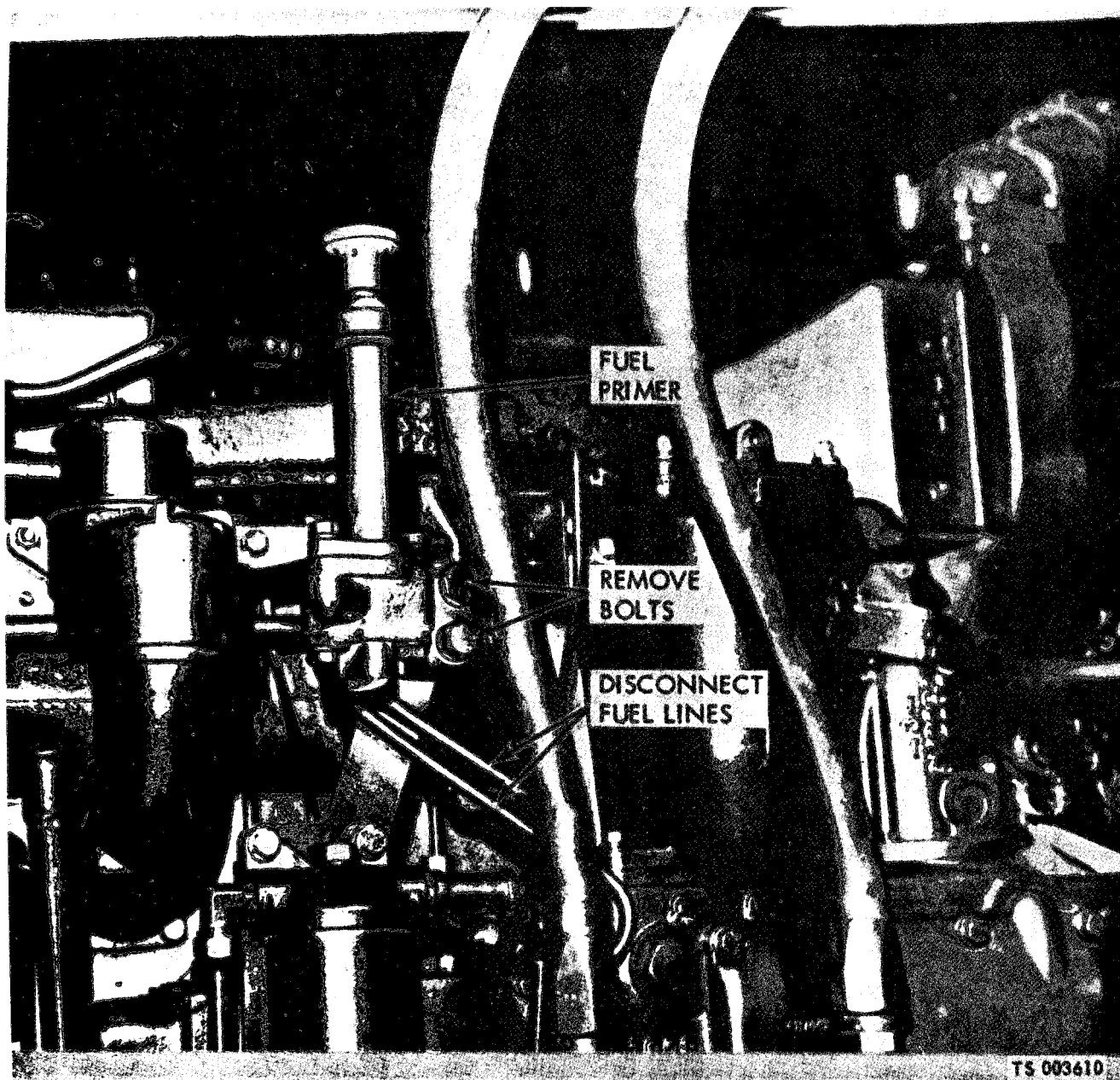

Figure 4-22. Removing fuel primer.

#### 4-28. Fuel Transfer Pump

a. *General.* The gear-type fuel transfer pump is mounted on the bottom of the accessory drive housing and is driven by the accessory shaft.

b. *Removal.*

- (1) Remove crankcase guard.
- (2) Close fuel line valve at fuel tank (fig. 3-3).

(3) Remove fuel transfer pump as illustrated in figure 4-23.

#### NOTE

Liner pump carefully to prevent loss of the rubber seals. Replace seals if damaged.

c. *Cleaning and Inspection.*

- (1) Clean outside of pump and inspect gear for wear or damage.
- (2) If pump or drive gear is defective, send to direct support maintenance for repair.

*d. Installation.* Install pump in reverse order of removal.

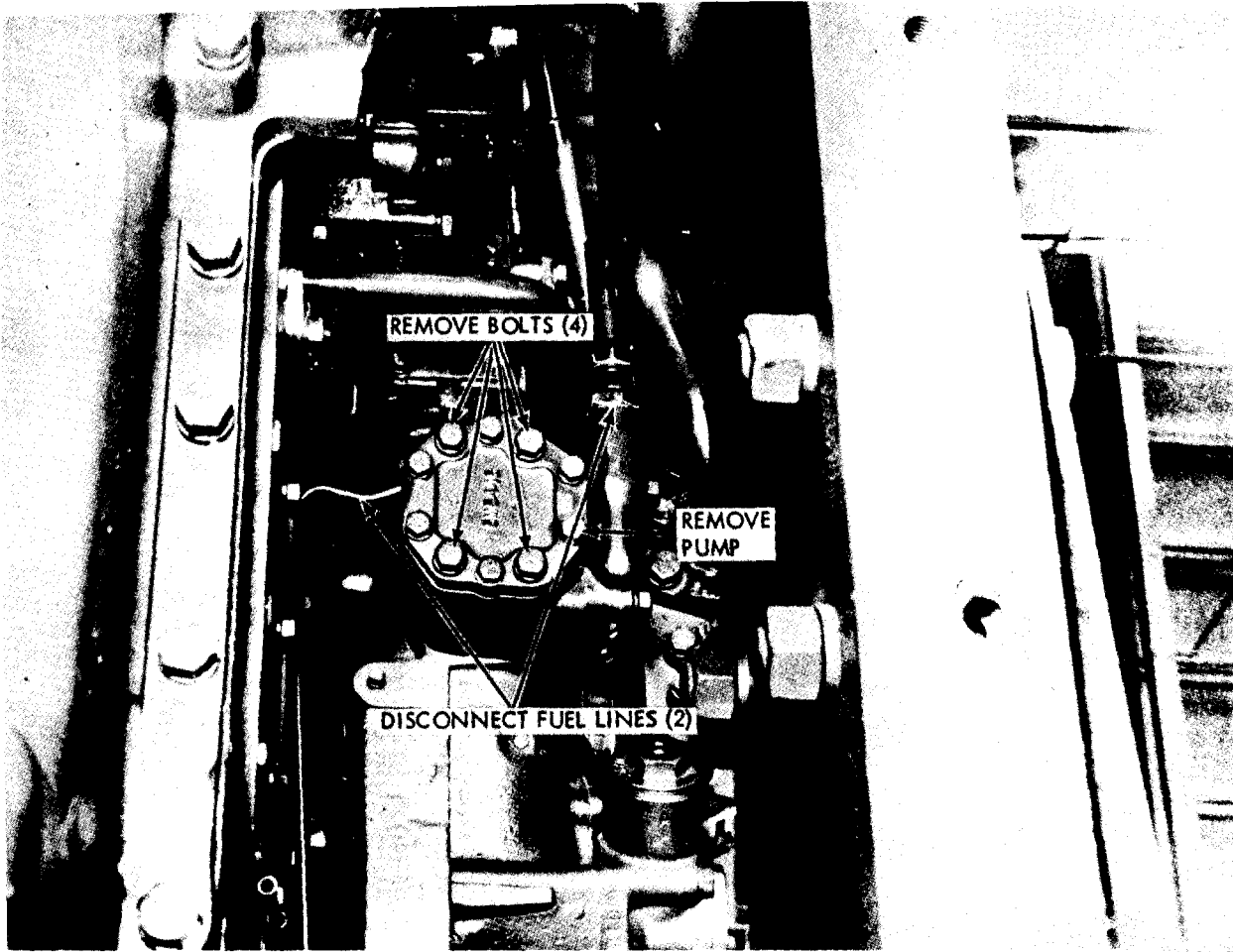

TS 003611

*Figure 4-23. Fuel transfer pump, removal and installation.*

#### 4-29. Fuel Tank and Lines

*a. Fuel Lines.* Refer to figure 4-24 for replacement of fuel lines. Keep lines and fittings clean and check occasionally for leaks or damage.

*b. Fuel Tank Cap.* Wash the fuel tank filler cap elements every 50 to 250 service hours depending upon the amount of dust or moisture in the air (fig. 4-25).

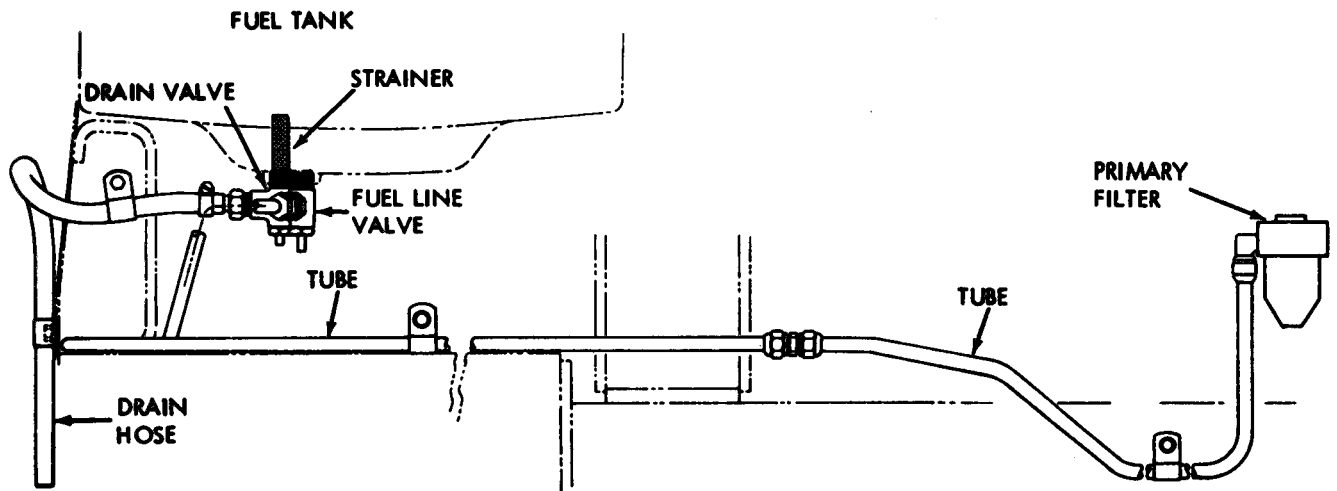

TS 003612

Figure 4-24. Fuel lines.

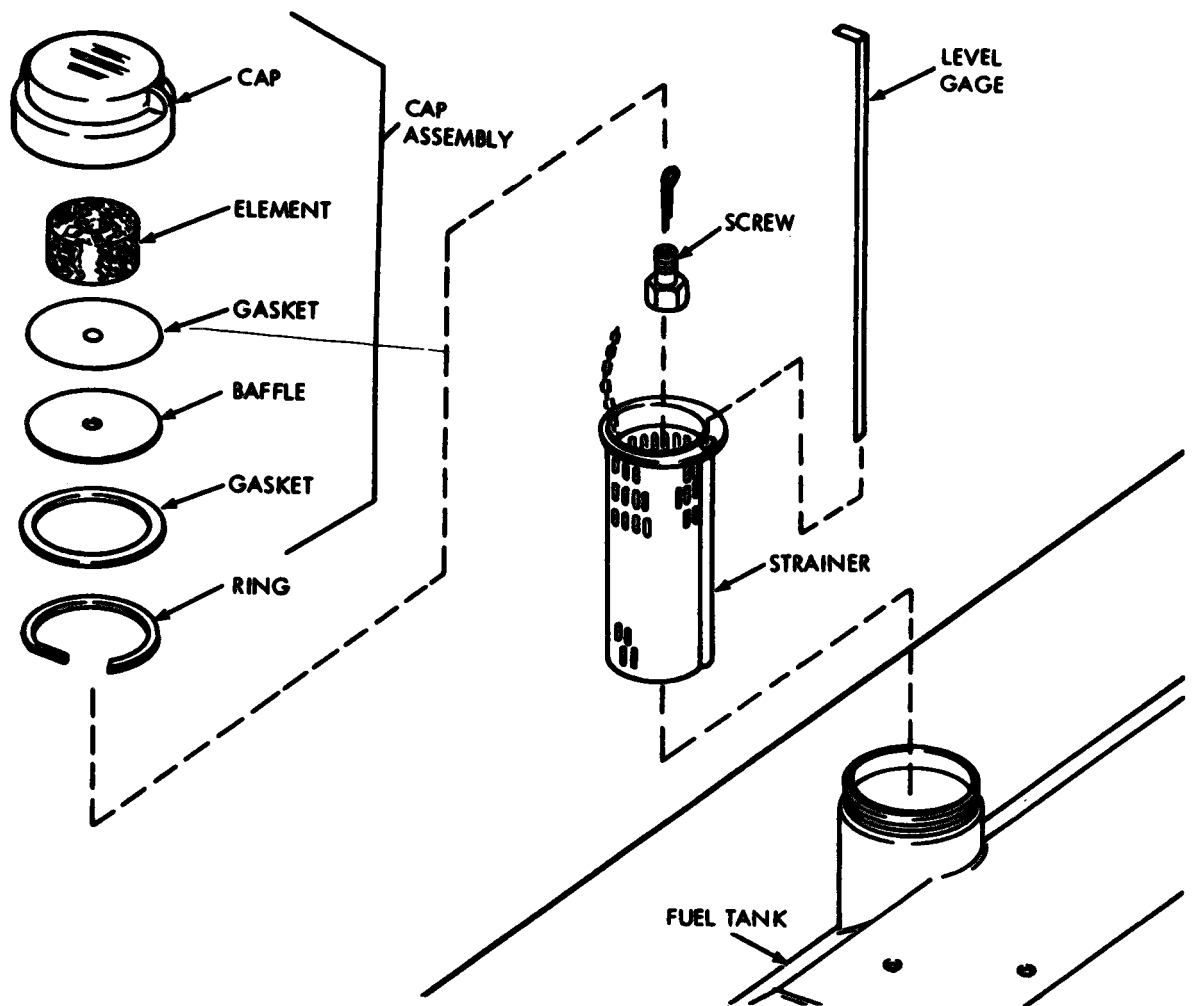

TS 003613

Figure 4-25. Fuel tank cap and strainer.

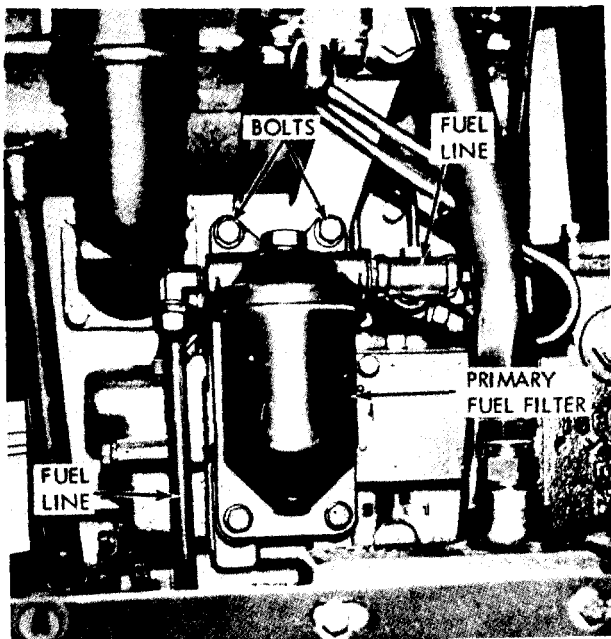

A REMOVING FUEL FILTER

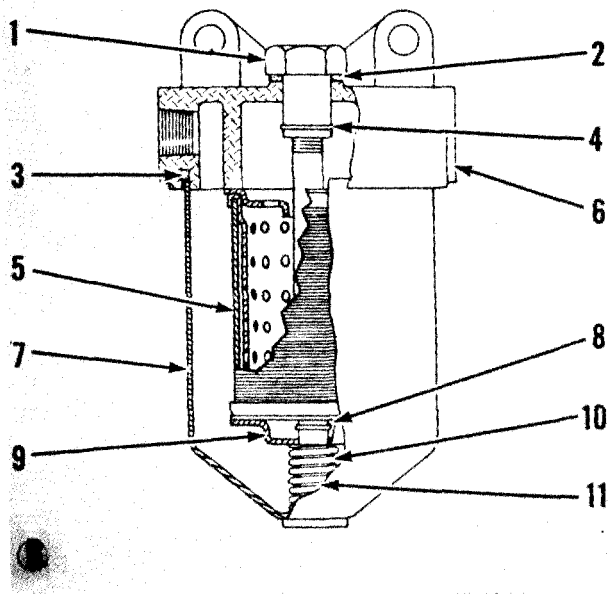

B PRIMARY FUEL FILTER DISASSEMBLY

TS 003614

- |            |                  |
|------------|------------------|
| 1. Nut     | 7. Case assembly |
| 2. Gasket  | 8. Ring          |
| 3. Gasket  | 9. Retainer      |
| 4. Ring    | 10. Spring       |
| 5. Element | 11. Sediment     |
| 6. Cover   |                  |

Figure 4-26. Primary fuel filter removal and disassembly.

### 4-30. Primary Fuel Filter

a. *General.* The primary fuel filter is located in the supply line between the fuel tank and the fuel transfer pump. Fuel from the tank enters the filter assembly, passes through the washable metallic element and on the transfer pump. Any abrasive material or sediment which might damage the fuel transfer pump is removed by the filter element and settles to the bottom of the case assembly.

b. *Removal.*

- (1) Shut off fuel at fuel tank (fig. 3-3).
- (2) Disconnect fuel lines (fig. 4-26).
- (3) Remove bolts and the filter.

c. *Disassembly.* The force of the spring ((10) B, fig. 4-26), acting against retainer (9), holds element (5) against cover (6) forming an effective seal between filtered and unfiltered fuel. Gaskets (2) and (3) prevent escape of fuel from unit. Rings (4) and (8) prevent loss of nut (1), spring (10), and retainer (9), when the unit is disassembled for cleaning. Refer to figure 4-26 to disassemble the fuel filter.

d. *Cleaning and Inspection.* Clean all parts and inspect for damage. Replace all damaged parts, gaskets, and seals as necessary.

e. *Reassembly.* Reassemble filter in reverse order of disassembly.

f. *Installation.* Install filter in reverse order of removal.

### 4-31. Final Fuel Filter

a. *Removal.*

- (1) Shut off fuel at fuel tank.
- (2) Drain fuel from fuel filter housing.
- (3) Disconnect fuel lines (fig. 4-27).
- (4) Remove bolts.
- (5) Remove housing.

b. *Disassembly and Cleaning.* Refer to paragraph 4-25.

c. *Reassembly and Installation.* Refer to paragraph 4-25 to reassemble final filter. Install in reverse order of removal.

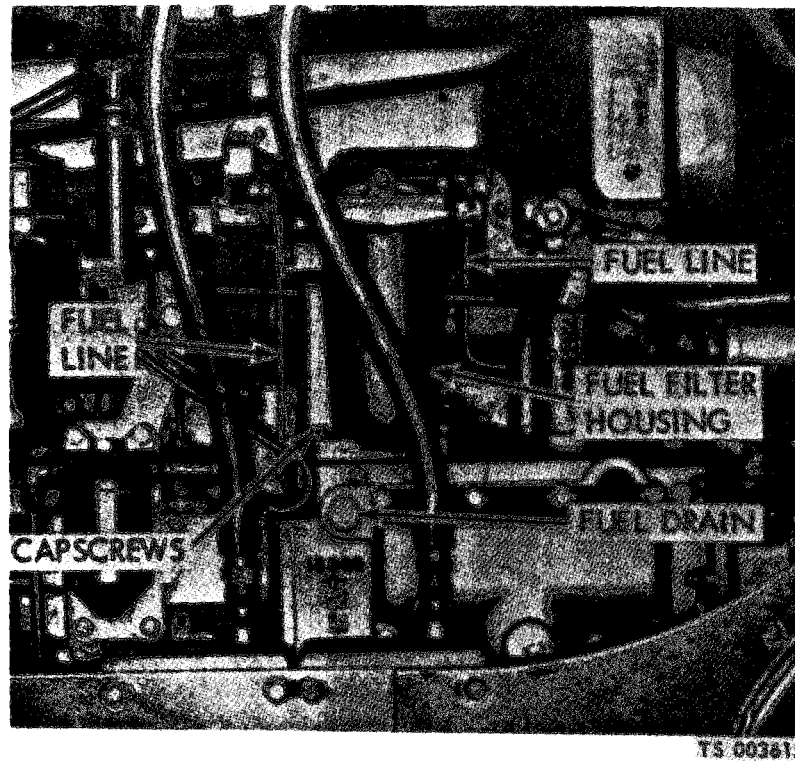

Figure 4-27. Final fuel filter housing removal and installation.

#### 4-32. Glow Plugs

*a. General.* A glow plug is installed in each of the four precombustion chambers (fig. 4-28).

*b. Removal.*

- (1) Disconnect lead from glow plug.
- (2) Unscrew glow plug from precombustion chambers.

*c. Cleaning and Inspection.*

- (1) Clean glow plug in an approved solvent.
- (2) Inspect visually for damage or defects.

*d. Installation.*

- (1) Prior to installation, coat glow plug threads with antiseize compound.
- (2) Torque plugs to  $\pm 2$  ft-lbs.



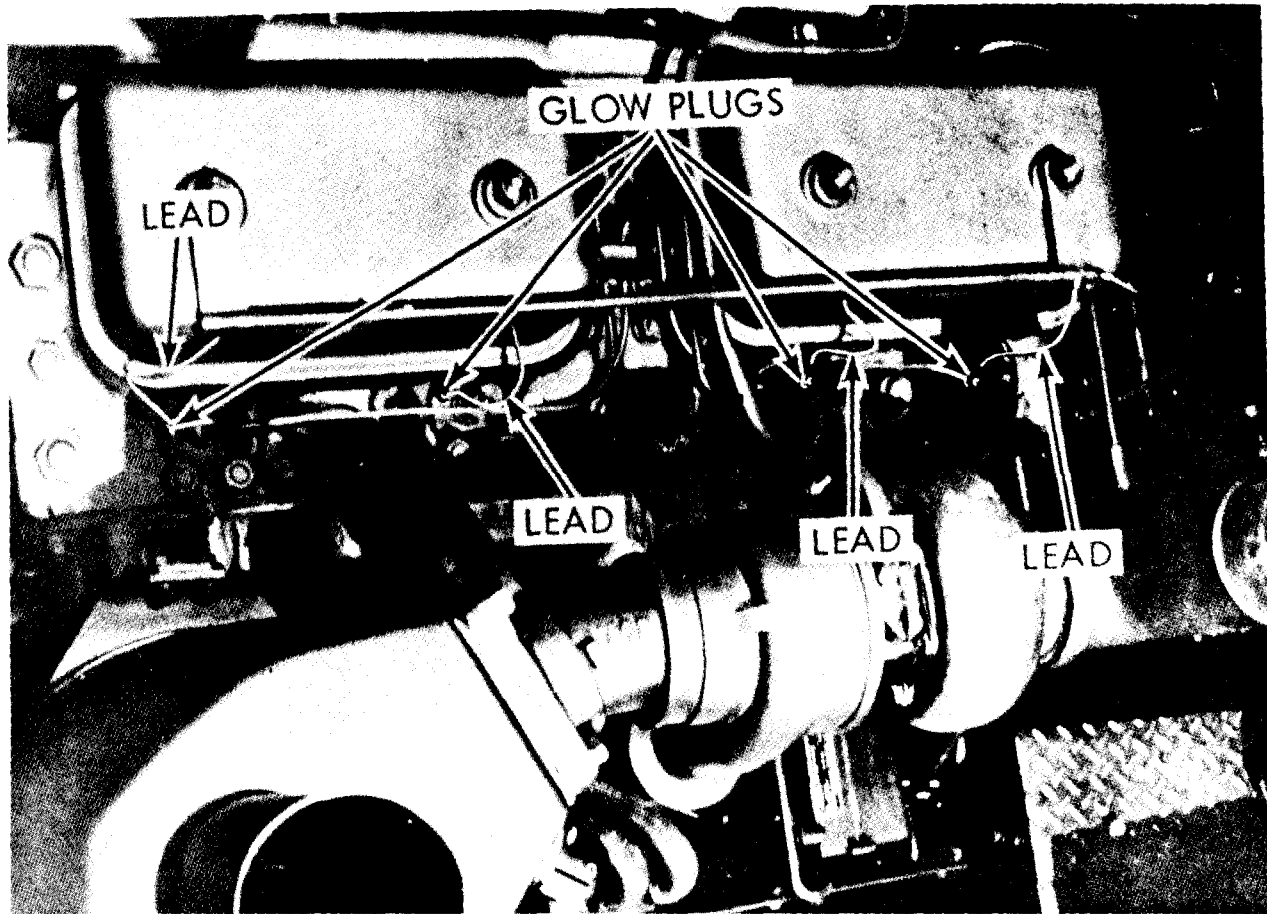

Figure 4-28. Glow plugs removal and installation.

## Section XII. COOLING SYSTEM

### 4-33. General

*a. Coolant Flow* (Fig. 4-29). Coolant is circulated by the water pump through the engine cooler and transmission oil cooler to the cylinder block and then passes through the cylinder head, into the water manifold and the radiator.

*b. Thermostat Operation.* When the coolant is cold and the thermostats are in the closed

position, all flow to the radiator is blocked and approximately 80 percent of the normal engine coolant flow passes through the bypass line and circulates through the system. As the coolant temperature increases and the thermostats open to allow coolant to the radiator inlet, the bypass flow diminishes. When the thermostats are fully open, all bypass flow is shut off.

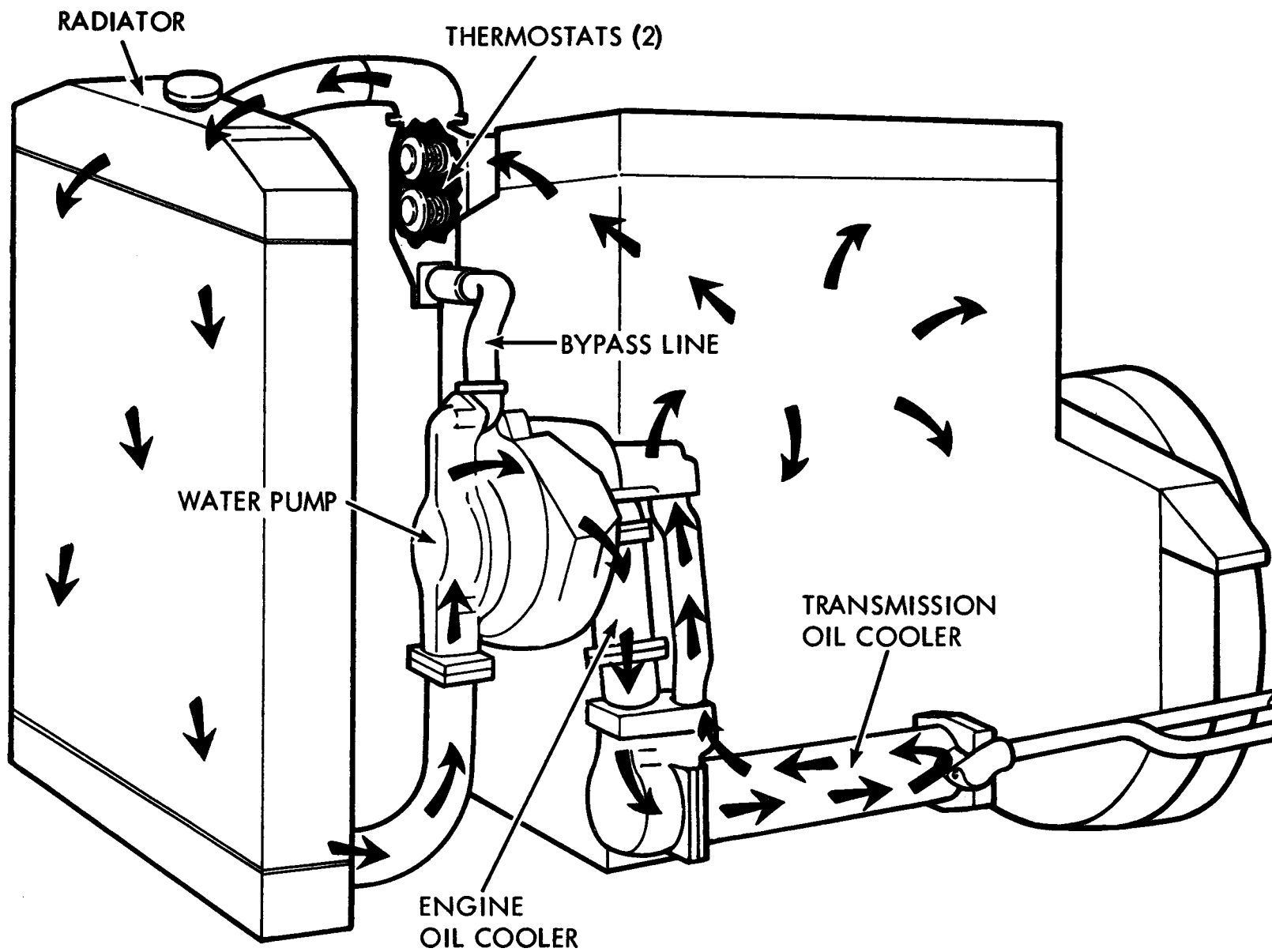

Figure 4-29. Flow of coolant.

**4-34. Radiator Guard**

*a. Removal.* Remove guard as illustrated in figure 4-30.

*b. Cleaning and Inspection.*

(1) Clean all parts with an approved solvent and dry thoroughly.

(2) Inspect all parts for cracks, breaks or other damage.

*c. Installation.* Install guard as illustrated in figure 4-30.

REMOVE PINS TO OPEN GRILLE SECTION OR TO REMOVE GRILLE

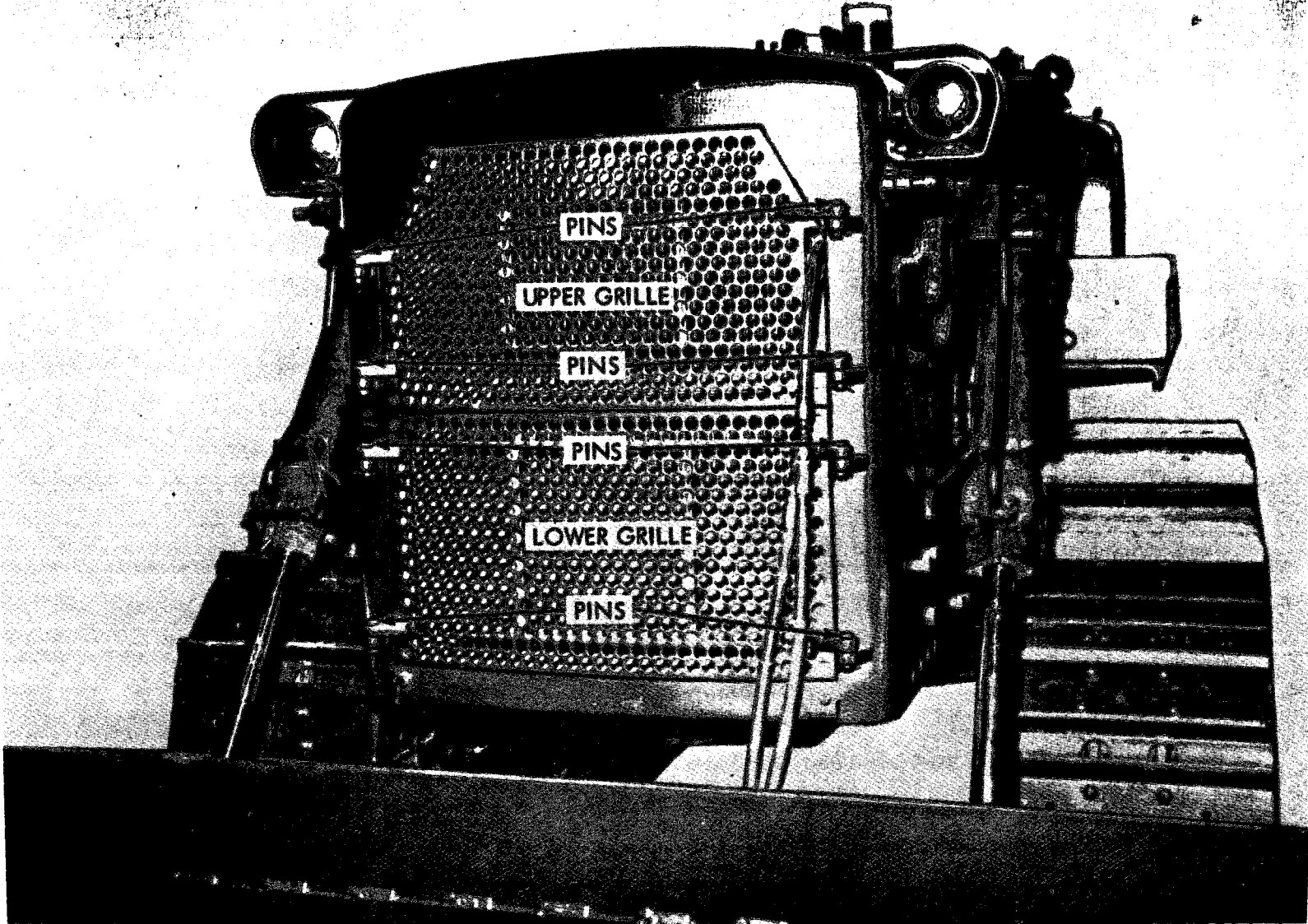

TS 003618

Figure 4-30. Radiator guard, removal and installation.

**4-36. Hoses, Lines, Fittings**

*a. Removal.*

(1) Drain coding system (para 3-9).

(2) Refer to figure 4-31 and remove clamps, hoses, lines, fittings.

*b. Cleaning, Inspection, Repair.*

(1) Clean parts with an approved solvent and dry.

(2) Inspect hoses for cuts or deterioration.

(3) Inspect tubes for breaks, cracks, or corrosion.

(4) Replace defective parts.

*c. Installation.* Install in reverse order of removal.

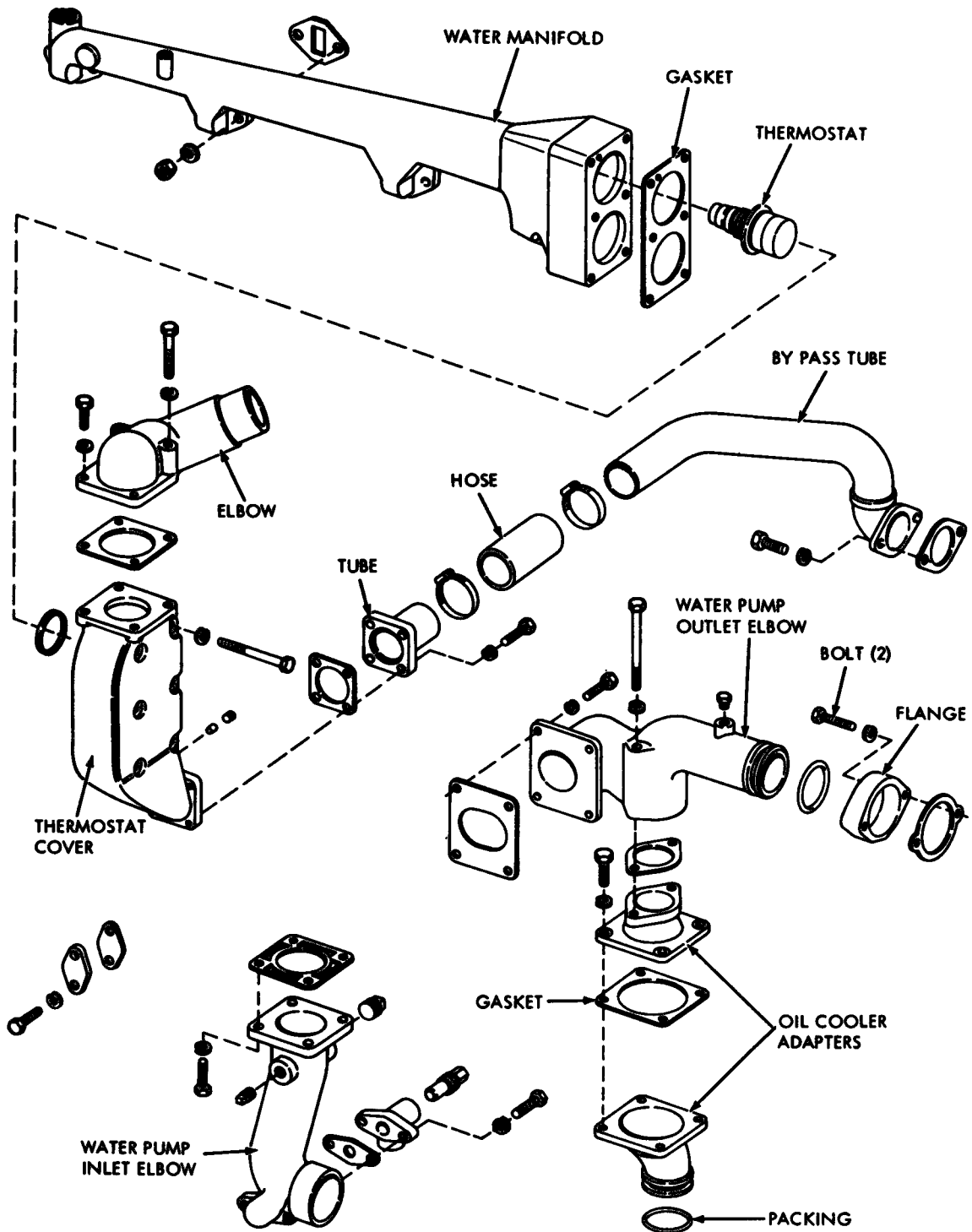

TS 003619

Figure 4-31. Water lines and fittings.

#### 4-36. Thermostats

*a .General.* Two thermostats, located in the cover at the front of the water manifold, restrict the flow of coolant through the radiator until the

correct engine operating temperature is maintained. The thermostats are designed for a minimum cooling temperature of 160 F. (71 C). The maximum operating temperature will vary

according to air temperature and load factor but should never exceed boiling temperature at the prevailing altitude.

*b. Thermostat Removal.* Remove thermostats as illustrated on figure 4-32.

*c. Testing Thermostats.*

(1) Remove thermostat from cover.

(2) Suspend thermostat in a pan of water.

(3) Apply heat to the pan and stir the water to maintain uniformity.

(4) Use an accurate thermometer to check water temperature.

(5) Observe the opening temperature of the thermostat.

(6) Replace the thermostat if it does not operate correctly.

*d. Thermostat Installation.* Install thermostats as illustrated in figure 4-32.

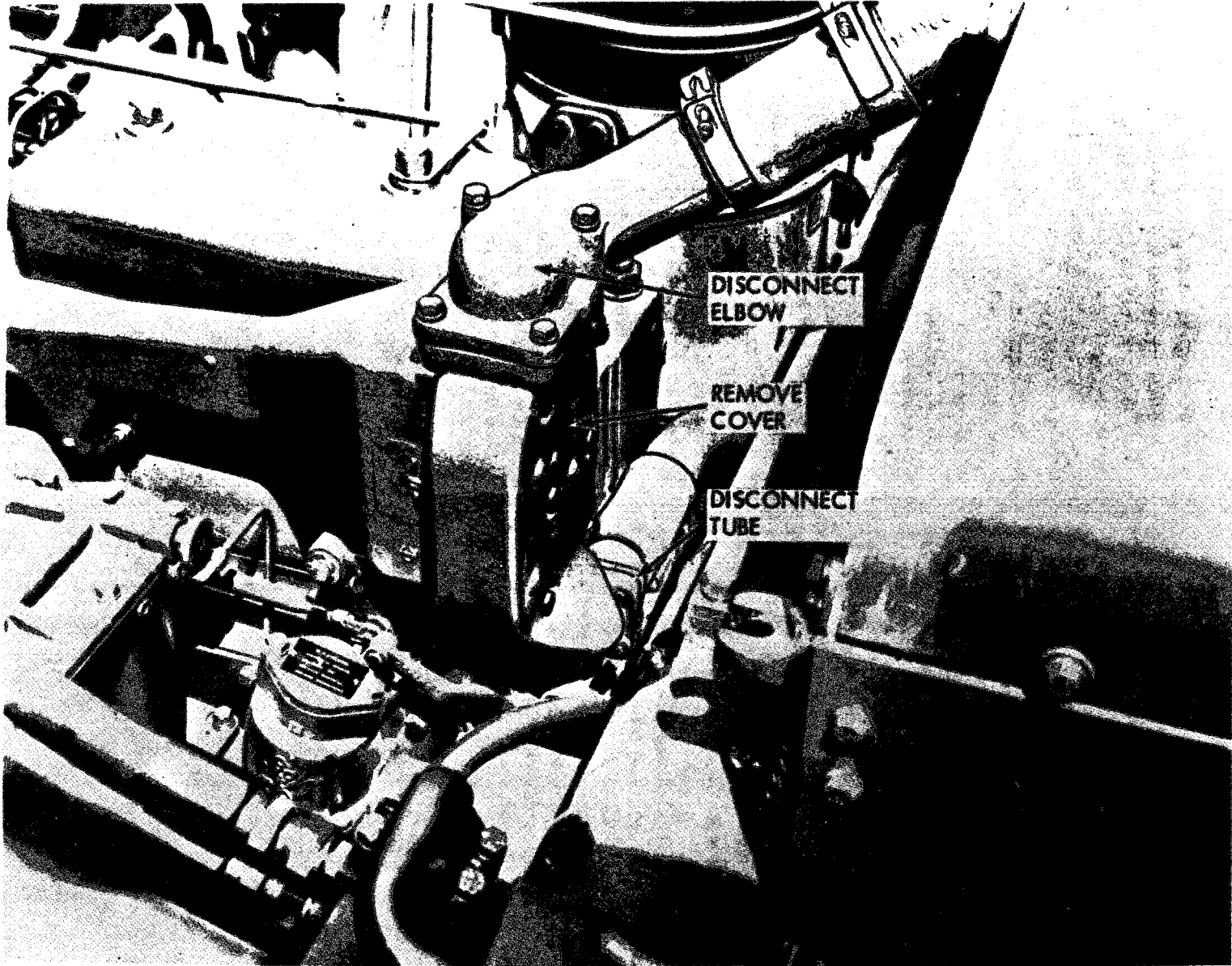

TS 003620

Figure 4-32. Removing thermostat.



#### **4-37. Radiator Sealed Pressure Overflow Unit (Serial Nos. 75E1-through 75E1300)**

*a. General.*

(1) A sealed pressure overflow assembly prevents loss of coolant through the radiator overflow tube when operating at an angle.

(2) Due to expansion of the coolant by rising temperature, a pressure will be built up in the cooling system each time the engine is started. When the pressure rises above 10 psi, pressure relief valve (1, fig. 4-33 (sheet 1 of 2)) opens to relieve the pressure or if the cooling system has been overfilled, allows some coolant to escape through the radiator overflow tube. The valve closes when the temperature of the coolant levels off and remains closed unless there is a further increase in pressure.

(3) When the temperature of the coolant falls, a vacuum will result in the cooling system. When the vacuum reaches 2.5 psi, vacuum release valve (4) opens and lets in air through the overflow tube. This vacuum release valve also functions when draining the cooling system.

*b. Disassembly and Service* (Fig. 4-33 (sheet 1 of 2)).

(1) Clean the sealed pressure overflow unit every 1,000 service hours to remove lime deposits and other accumulations which might hold the valve in the "open" position. Such deposits are not so noticeable where inhibitors are used in the cooling system, but regular cleaning of the unit should be performed.

(2) To clean the unit, disassemble by

removing the screws which hold the cover in position. Lift off the cover, then remove the seal assembly and brush the parts thoroughly until all of the foreign matter has been removed.

**CAUTION**

**To prevent damage to the seal, do not wash the unit in a cleaning solution.**

*c. Reassembly.* When reinstalling gaskets (6) (one on each side of the seal), make sure the correct hole in the gasket aligns with opening (5) to the overflow tube.

#### **4-38. Radiator Sealed Pressure Overflow Unit (Serial No. 75E1301-UP)**

*a. General.*

(1) A sealed pressure overflow assembly prevents loss of coolant through vent hole in pressure relief valve cover, when operating at an angle.

(2) Due to expansion of coolant by rising temperature, a pressure will be built up in cooling system each time engine is started. When pressure rises above 13.4 psi, pressure relief valve (3, fig. 4-33 (sheet 2 of 2)) opens to relieve pressure, or if cooling system has been overfilled, allows some coolant to escape through vent hole in valve cover.

(3) When temperature of coolant falls, a vacuum will result in cooling system. When the vacuum reaches 2.5 psi, vacuum release valve (located in cover) opens and lets air enter through vent hole in valve cover. This vacuum release valve also functions when draining cooling system.



TS 003421

*Figure 4-33. Radiator sealed pressure overflow unit (sheet 1 of 2). (Serial Nos. 75E1 through 75E1300).*

KEY to figure 4-33 (sheet 1 of 2).

- |                          |                          |
|--------------------------|--------------------------|
| 1. Pressure relief valve | 5. Open to overflow tubs |
| 2. seal                  | 6. Gaskets               |
| 3. Screen                | 7. Cover                 |
| 4. Vacuum release valve  |                          |

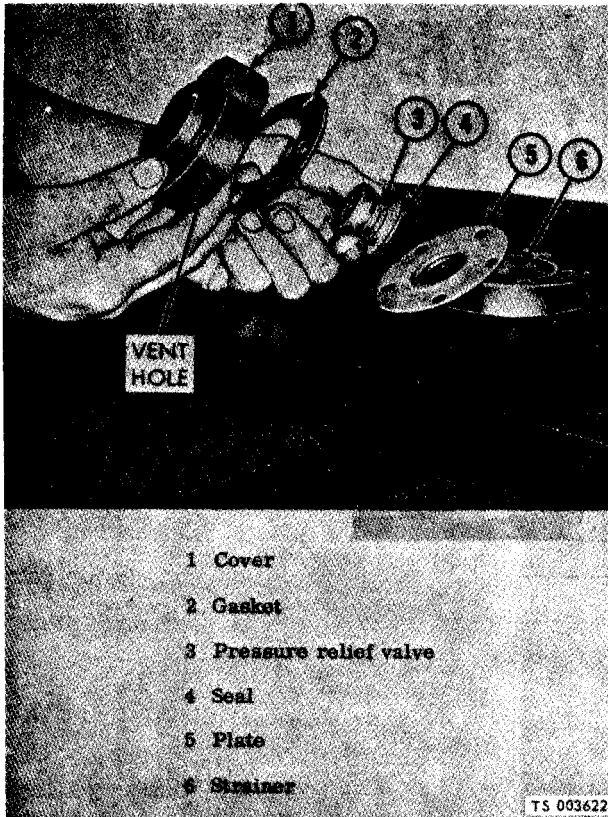

- |                          |             |
|--------------------------|-------------|
| 1. Cover                 | 4. Seal     |
| 2. Gasket                | 5. Plate    |
| 3. Pressure relief valve | 6. Strainer |

Figure 4-33. Radiator sealed pressure overflow unit (sheet 2 of 2 ). (Serial Nos. 75E1301 and up).

b. *Disassembly and Service.* Refer to paragraph 4-37 b to disassemble and service unit.

c. *Reassembly.* When reinstalling, be certain gaskets (2, fig. 4-33 (sheet 2 of 2) are correctly positioned and vent hole in valve cover is towards rear side of radiator top tank.

**4-39. Cap Assembly**

a. Cap assembly allows coolant to be added and also when installed, prevents loss of coolant, See figure 4-34.

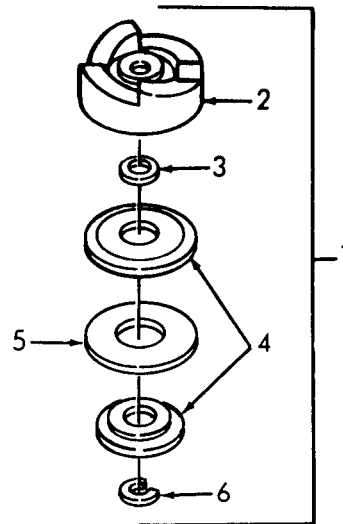

TS 003623

Figure 4-34. Cap assembly, exploded view.

b. *Inspect.* Clean and inspect cap for worn gasket.

c. *Disassembly.* Remove snap ring (6) to disassemble cap.

d. *Reassembly.* Order of reassembly is as follows: Install insert (3) over threaded shaft in radiator cap (2). Next install gaskets (4), flat rubber washer (5). Snap ring (6) is then placed over threaded shaft in radiator cap (2). The cap assembly is now complete.

**4-40. Fan Belts and Generator Belt**

a. *General.* The fan is driven by two V-belts from a pulley on the crankshaft. The fan belts operate under the spring tension of a belt tightener. The generator is driven by a single belt from the fan hub.

b. *Fan Belt Replacement* (A, fig. 4-35).

- (1) Remove hood.
- (2) Remove two bolts at top of belt tightener mounting bracket.
- (3) Loosen three nuts on mounting bracket studs.
- (4) Loosen belt tightener bracket support adjusting bolt locknut and loosen the adjusting

bolt enough to permit the belt tightener bracket to move downward the required distance to permit fan belt removal and installation.

(5) Slip belts off the belt tightener pulley and pull them upward and off the fan pulley.

(6) It maybe necessary to turn the fan belts to clear the narrow opening between the crankshaft puller and the fan shroud.

(7) Install new belts, tighten the belt tightener bracket support adjusting bolt until the support bracket has moved upward as far as possible and tighten the adjusting bolt locknut. Install the two mounting bolts removed from the belt tightener bracket and tighten the bolts and three stud nuts. With the belt tightener bracket in this position the proper tension on the belts will be applied. Belt adjustment is not required.

*c. Generator Belt Replacement.*

(1) See preceding paragraph covering fan belt replacement.

(2) Remove the fan belts to the point where the belts can be lifted up and out of the fan drive pulley grooves.

(3) Loosen the nut on the generator pivot bolt ((1)B, fig. 4-35)) and the adjusting strap bolt (3).

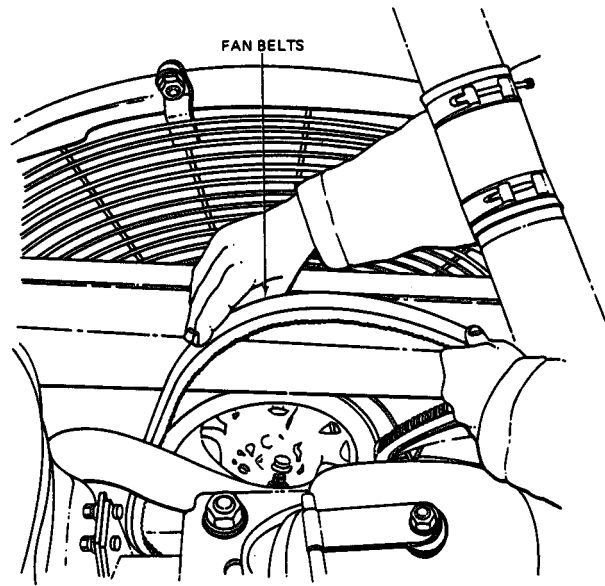

A. REMOVING FAN BELTS

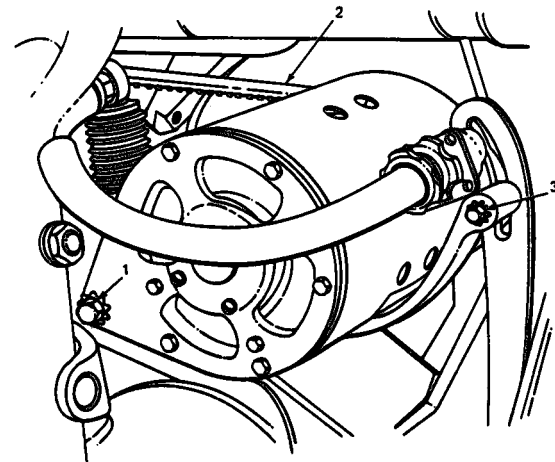

B. GENERATOR BELT REPLACEMENT

LEGEND:  
1. PIVOT BOLT  
2. DRIVE BELT  
3. STRAP BELT

TA 178546 ■

Figure 4-35. Removing and installing fan and generator belts.

(4) Push the generator inward towards the fan pulley and remove the generator drive belt (2).

(5) Install new belt in reverse order of removal. Adjust belt as described in paragraph 3-11.

#### 4-41. Fan and Fan Guard

*a. General.* The reversible type fan with movable blades, can function as a suction type fan or blower type fan by rotating the fan blades. To reverse fan action proceed as follows:

(1) Push in on fan blade an turn until blade locks in place in alternate position.

(2) Engage starter switch to turn fan hub. Be sure all blades are turned to same position.

#### **WARNING**

**Keep hands clear of fan assembly when turning engine.**

*b. Fan Guard Removal and Installation.* Refer to figure 4-36 to remove and install the fan guard.

*c. Cleaning and Inspection.*

(1) Clean guard and attaching parts with an approved solvent and dry thoroughly.

(2) Inspect guard for cracks, breaks, and other damage. Replace a damaged or defective guard.

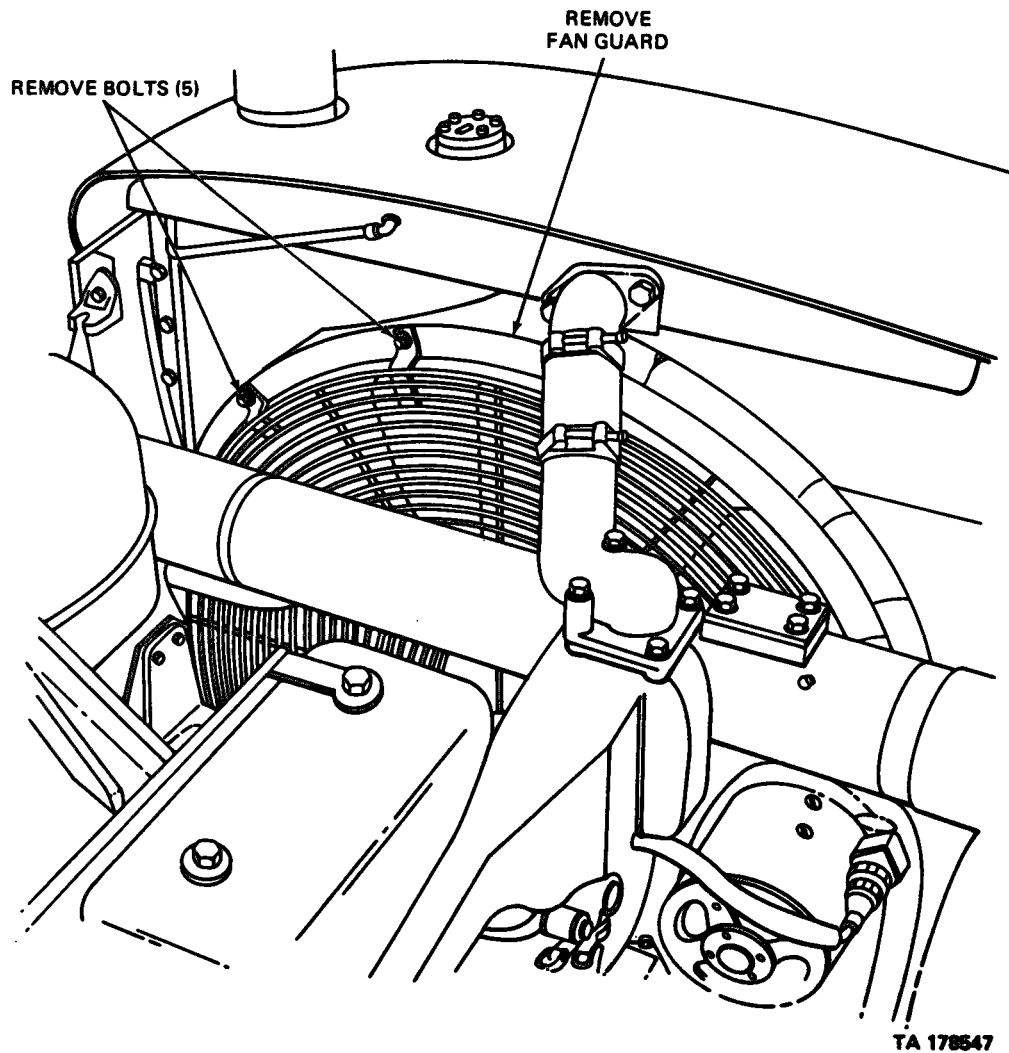

TA 178547

Figure 4-36. Fan guard, removal and installation.

### Section XIII. ELECTRICAL SYSTEM

#### 4-42. General

The electrical system is a 24-volt system composed of generator, generator regulator, starter, batteries, lights, switches, circuit breakers, instruments, and wiring harness. Four 12-volt

batteries are connected in series - parallel to provide 24-volt power. See figure 1-3 for wiring diagram. A slave receptacle is located on the dash in a 10 left left position. A disconnect switch is located on the left side of the seat assembly to the right of battery box.

Change 1

**4-43. Generator**

*a. Brush Replacement (fig.4-37).*

(1) Loosen screw on brush cover band and slide band forward.

(2) Remove brush terminal screw, lift brush arm and remove brush. Repeat for other three brushes.

(3) Lift brush arm and install new brush. Secure lead with screw. Repeat for other three brushes, always replace the complete set.

(4) Seat brushes using a seating hone or No. 00 sandpaper.

(5) Position cover band on generator and tighten screw.

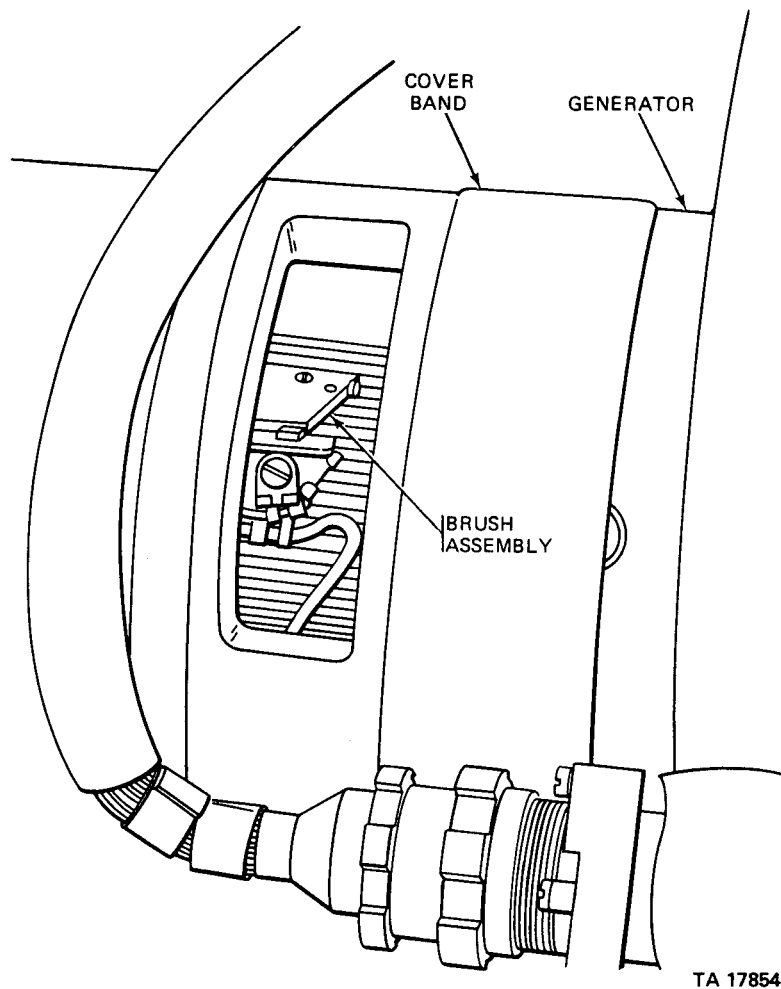

Figure 4-37. Replacing generator brushes.

*b. Generator Removal.* Refer to figure 4-38 and remove generator.

*c. Cleaning and Inspection.*

(1) Clean external surfaces of generator with clean cloth dipped in an approved solvent. Wipe dry.

(2) Inspect generator for cracked or broken housings. Inspect electrical receptacle connector and elbow for cracked or broken condition; inspect for deformed or broken contacts. Replace

generator if visual inspection indicate: it is defective.

*d. Installation.*

(1) Install generator in reverse order of removal as illustrated in figure 4-38.

(2) See figure 3-10 for generator belt adjustment.

**CAUTION**

**Polarize generator as instructed in paragraph 4-45 before starting engine.**

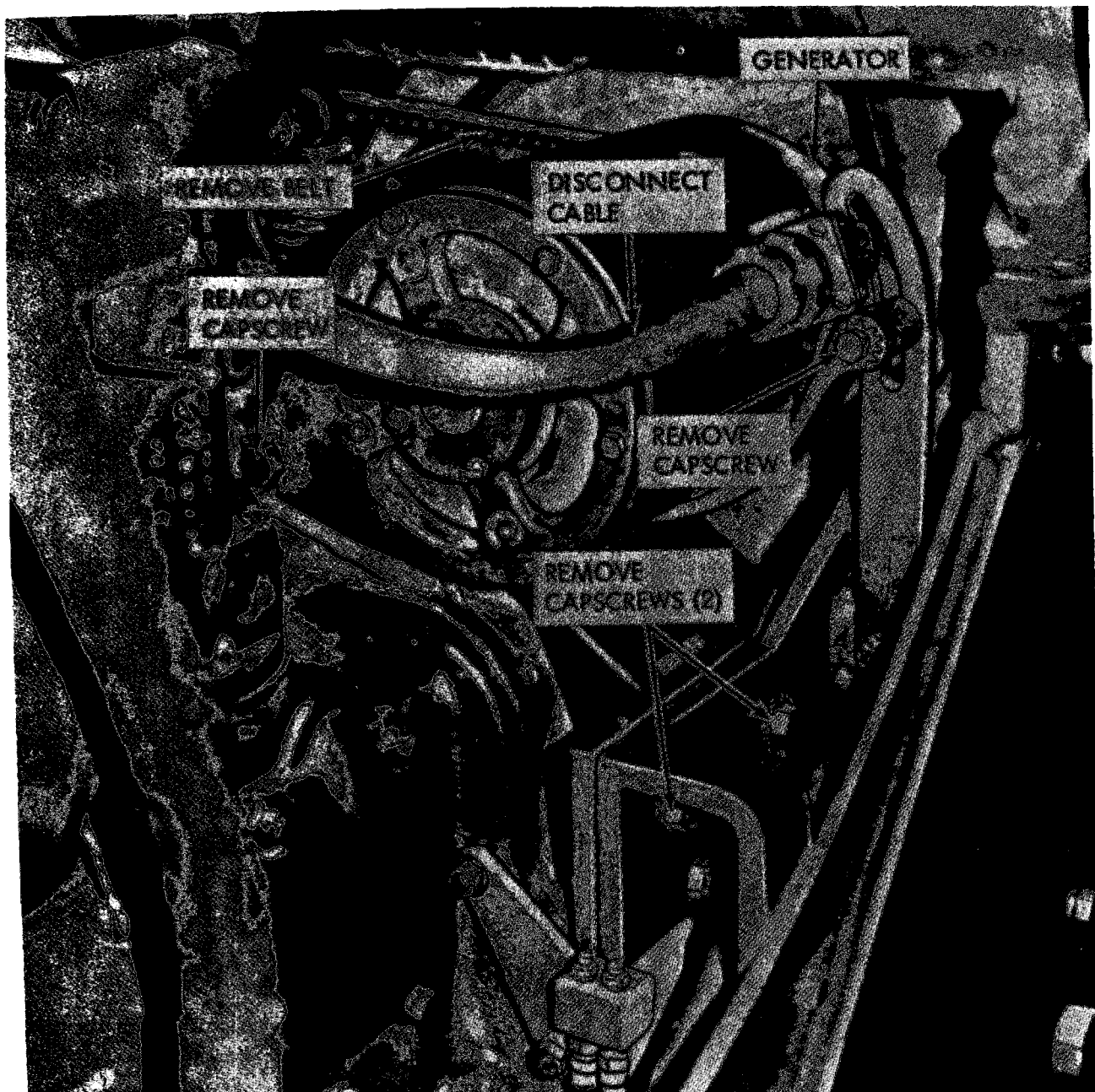

TS 003627

Figure 4-38. Generator removal and installation.

#### 4-44. Alternator for Generator Replacement

##### a. Removal.

- (1) Disconnect wiring harness from generator.
- (2) Loosen belt tightener harness from generator.
- (3) Remove belt tightener, generator, and bracket.
- (4) Remove all bolts holding wiring harness to the engine.

- (6) Disconnect wiring harness and ground jumper wire to voltage regulator.
- (6) Remove the wiring harness.
- (7) Remove regulator and bracket.
- (8) Remove all bolts holding ground jumper wire.
- (9) Disconnect wire from ammeter and remove wire.

##### b. Installation.

- (1) Install the pulley on the alternator (fig. 4-39).



- (2) Tighten the nut to  $75 \pm 5$  lb ft. torque.
- (3) Install bracket (1), alternator (2), and belt tightener (3).
- (4) Install ground connector (4) to the alternator (2) and to a good connection on the engine.
- (5) Install belts.
- (6) Install wire (5) to the alternator.
- (7) Route wire from alternator to circuit breaker bracket and secure with clamps.

- (8) Install bracket.
- (9) Install instruction plate (6) and circuit breaker (7) to bracket (8).
- (10) Install grommet clip and diode (9).
- (11) Install wires (10) and (11).
- (12) Connect wire (5) to circuit breaker (7) as shown (minus -) connection.
- (13) Connect a wire from plus (+) connection on circuit breaker (7) to ammeter.

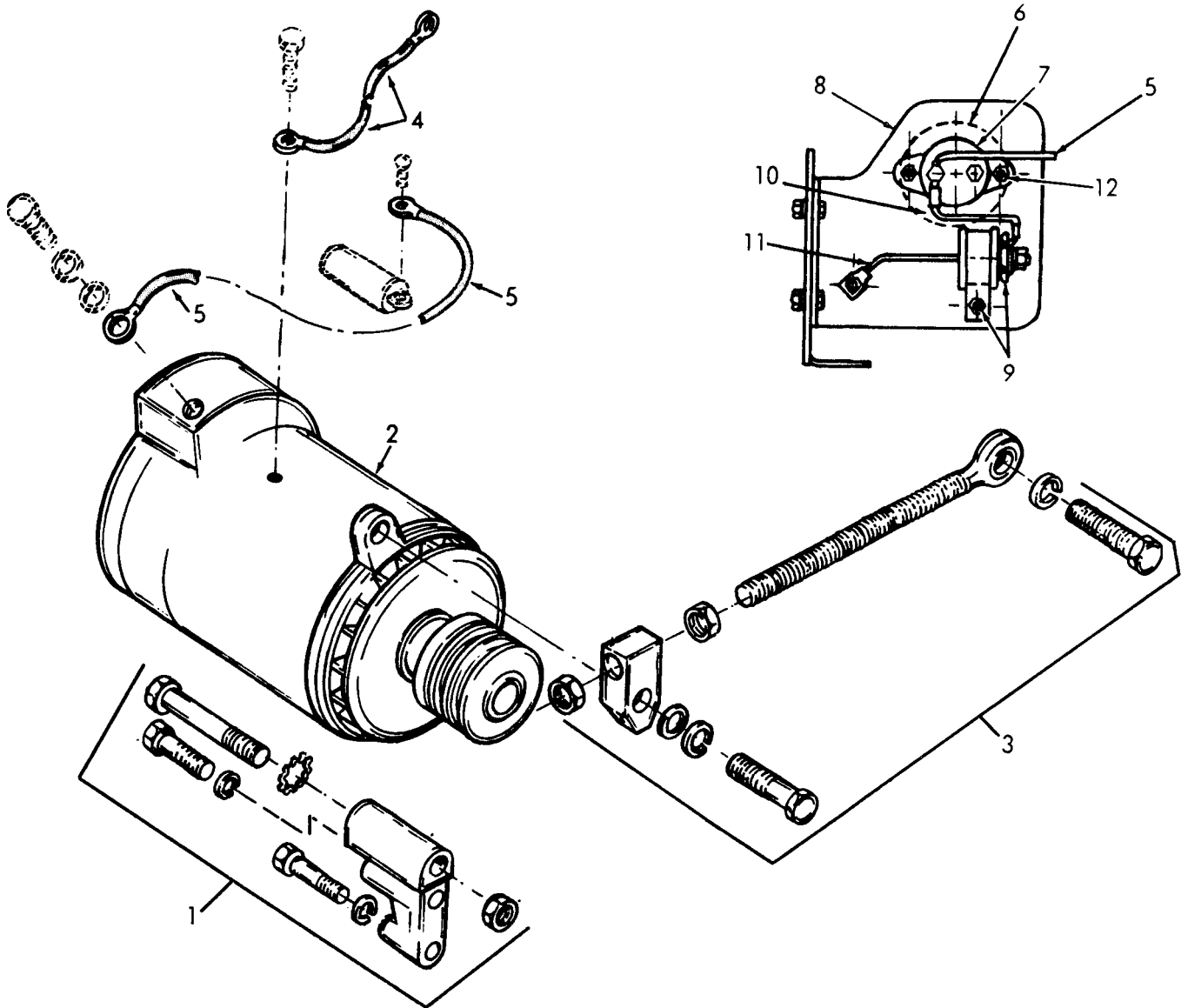

- |   |  |
|---|--|
| <ul style="list-style-type: none"> <li>1. BRACKET ASSEMBLY</li> <li>2. ALTERNATOR</li> <li>3. BELT TIGHTENER ASSEMBLY</li> <li>4. GROUND WIRE</li> <li>5. ALTERNATOR-TO-CIRCUIT BREAKER WIRE</li> <li>6. INSTRUCTION PLATE</li> </ul> | <ul style="list-style-type: none"> <li>7. CIRCUIT BREAKER</li> <li>8. BRACKET</li> <li>9. CLIP AND DIODE</li> <li>10. WIRE</li> <li>11. WIRE</li> <li>12. MOUNTING HARDWARE</li> </ul> |
|---|--|

TS 003628

Figure 4-39. Alternator.

#### 4-45. Generator Regulator

##### a. General.

(1) The generator regulator is a watertight, fungus and corrosion resistance unit for military applications. It is a heavy-duty, 24 volt, 40 ampere regulator designed for use with a generator having an internally grounded field circuit. The unit is used in a system having a negative ground. Terminals of the regulator are housed in special receptacles conforming to Ordnance specifications. Connections to the regulator are made by means of mating Ordnance-type receptacles on the vehicle wiring harness.

(2) The regulator consists of three units: a cutout relay, current regulator and voltage regulator. The gasket between the regulator cover and the base has metal staples through it which aid in radio suppression by insuring good electrical contact between the cover and the base. One capacitor for radio suppression is mounted in the base of the regulator. This capacitor, a "Feed Thru-Type, is connected in the circuit between the output receptacle and the lower contacts of the cutout relay.

(3) The cutout relay is designed to close the circuit from the generator to the battery when generator voltage is sufficient to charge the battery and to open the circuit when the generator slows or stops. The cutout relay has a counterbalanced armature by means of a weighted overhang at the hinge end. This stabilizes the armature when it is in the open position making it less likely to be jarred or bounced closed by shock or vibration. The counter-balance part of the armature is provided with a stop which prevents the hinge spring from being permanently damaged if subjected to shock.

(4) The current regulator is a current-limiting device which protects the generator by preventing it from exceeding its maximum safe output .

(5) The voltage regulator is a limiting device which prevent the generator voltage from exceeding a predetermined maximum. With voltage limited, the generator delivers varying outputs as required for changing battery conditions and electrical loads.

##### b. Regulator Removal and Installation.

(1) Disconnect regulator to junction block wire at regulator (fig. 4-40).

(2) Unscrew coupling of generator-to-regulator cable.

(3) Remove four bolts and lift generator regulator from tractor.

(4) Install regulator in reverse order of removal.

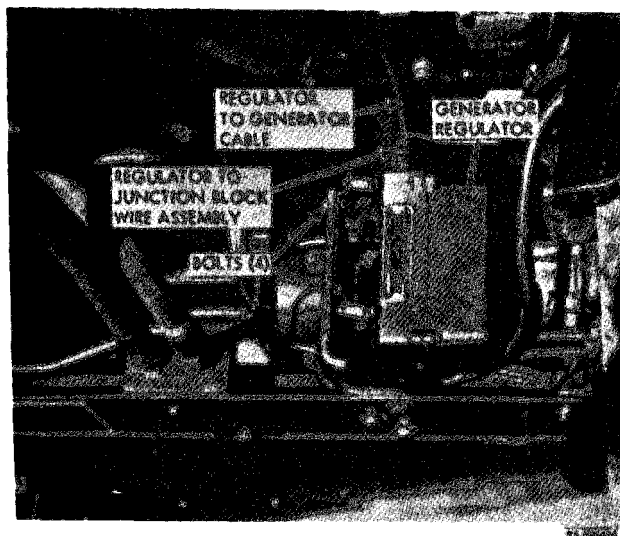
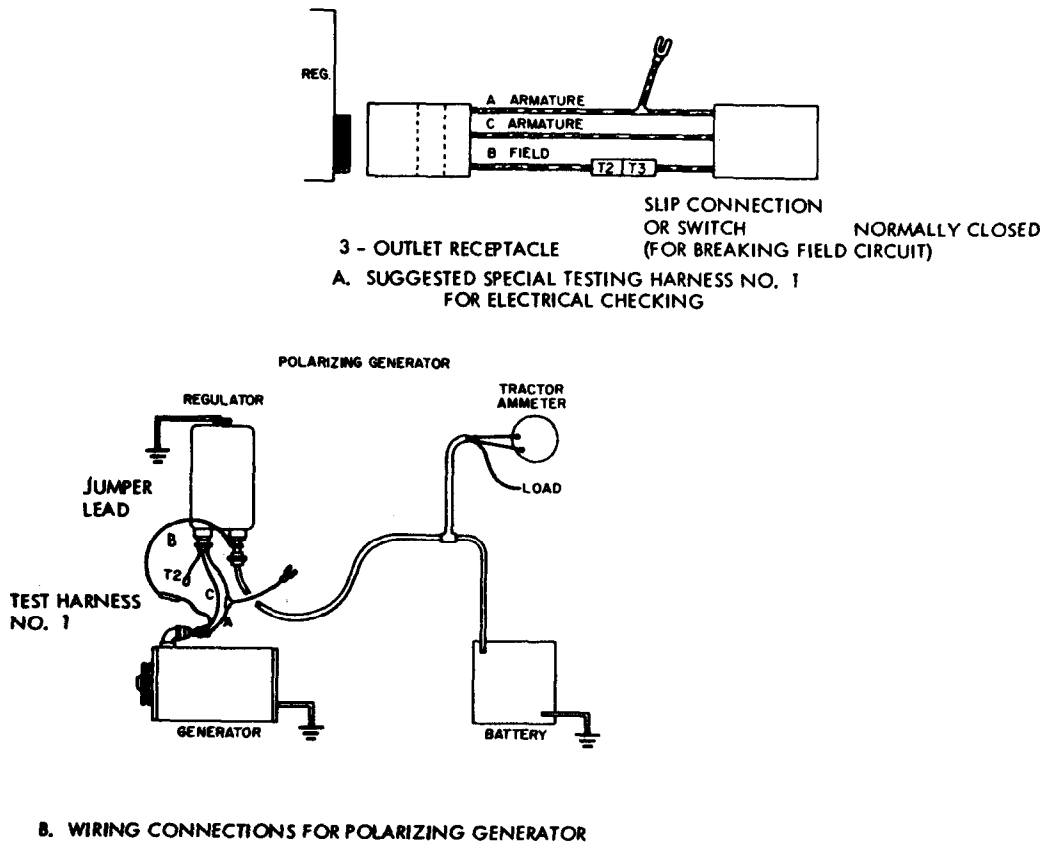

Figure 4-40. Generator regulator removal and installation.

#### CAUTION

**When a regulator has been removed from the vehicle or leads disconnected from the regulator, the generator must be polarized after leads are reconnected but BEFORE THE ENGINE IS STARTED. To polarize the generator (with the Special Testing Harness No. 1 (fig. 4-41) inserted in generator circuit, T-2 and T-3 disconnected making an open field circuit and with the battery cable disconnected from the regulator momentarily touch a jumper lead between the T-3 of Harness No. 1 and the prong of the battery cable. This allows a surge of current to flow through the generator field windings in the proper direction. Failure to do this may result in severe damage since reversed generator polarity causes vibration, heavy arcing or welding of the cutout relay contact points.**



TS 003630

Figure 4-41. Wiring connections for polarizing generator.

#### 4-46. Starting Motor

a. *General* The 24-volt starting motor is mounted on an adapter attached to the flywheel housing on the left side of the engine.

b. *Removal* (fig. 4-42).

- (1) Turn disconnect switch to OFF position.
- (2) Remove generator regulator (para 4-45).
- (3) Disconnect and tag wires and cables attached to starter and to solenoid.
- (4) Remove three bolts and remove starting motor.
- (5) To remove solenoid, disconnect cables to solenoid and remove four bolts securing solenoid to starting motor.

c. *Cleaning and Inspection.*

- (1) Clean external surfaces of starter with a cloth dipped in an approved solvent. Wipe dry.
- (2) Inspect housings for cracks and inspect gear for cracks or chipped teeth. Replace starter if defective.

d. *Installation.* Install starting motor in reverse order of removal.

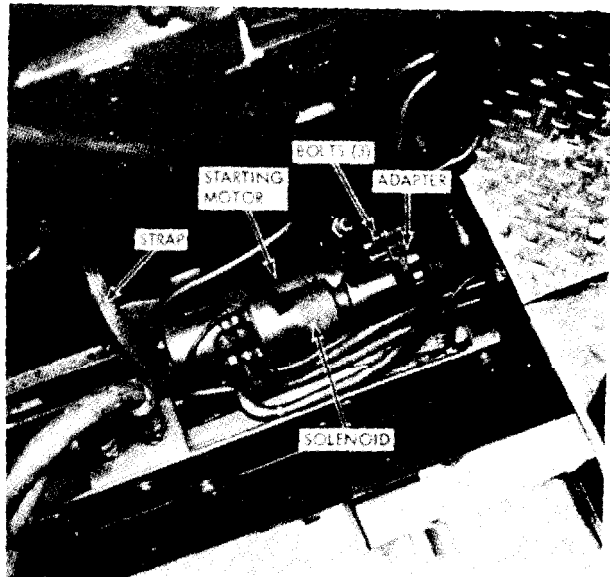

Figure 4-42. Starting motor, removal and installation.

**4-47. Ammeter and Instrument Panel Switches**

a. *Removal.* To remove ammeter, simply disconnect and tag wires and remove mounting hardware. Refer to figure 2-1 and figure 4-43 to locate and remove panel switches.

b. *Cleaning and Inspection.*

(1) Wipe switches and ammeter with a clean cloth.

(2) Clean and scrape any rust or corrosion from terminals.

(3) Inspect switches for damaged terminals. Inspect ammeter face for cracks. Replace a defective unit.

Figure 4-43 (Sheet 1 of 2). Deleted.

4-48. **Dashlights**

*a. General.* There are two dashlights located at the sides of the control tower.

*b. Removal.*

(1) Open access door in bottom of control tower.

(2) Remove two screws as shown in figure 4-43 to remove light.

*c. Cleaning and Inspection.*

(1) Wipe lightly with a clean cloth and inspect for cracked or broken cover.

(2) Inspect for corroded terminals and frayed, cut, or torn insulation.

(3) Replace entire assembly if case is cracked or broken.

*d. Installation.* Install in reverse order of removal.

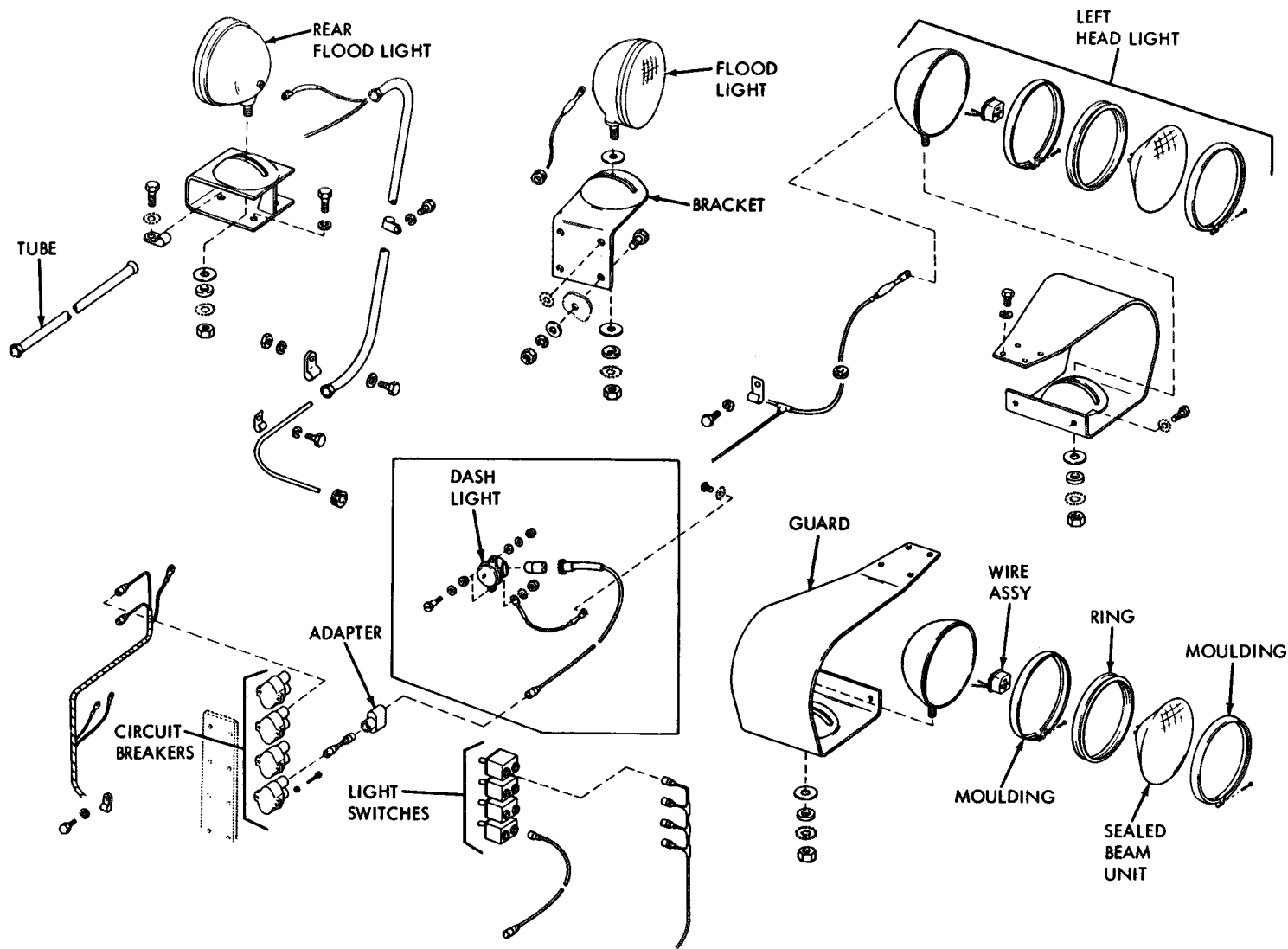

Figure 4-43. Switches and lights.

TS 003633 ■

#### 4-49. Headlights and Floodlights

a. *General.* The mounting of the lights is the same except the front lights are protected by a guard.

b. Removal. Refer to figure 4-43 and remove lights.

c. *Cleaning and Inspection.*

(1) Clean rust and corrosion from electrical connection. Clean outside of light with a clean cloth.

(2) Inspect shell and retainer for cracks. Inspect threads on mounting stud. Replace light if shell is defective. Replace retainer if cracked.

d. *Removal of Sealed Beam Units.* Refer to figure 4-43 for removal of sealed beam units.

e. *Installation.* Install as shown in figure 4-43.

f. *Adjusting Headlights or Floodlight.*

(1) To adjust light for radius, loosen hex nut below mounting bracket and position light as required. Hold in place and tighten nut.

(2) To adjust for angle, loosen hex-head bolt and nut on bracket and tilt as required. Tighten bolt and nut.

#### 4-50. Batteries

a. *Testing.* The battery should be tested with a hydrometer and kept to a specific gravity of 1.250 or above. Always test a battery for degree of charge before adding water. The specific gravity between the cells should be within 0.025. A dangerously low point of charge indicated by a hydrometer reading of 1.150 or less will permit the battery to freeze at temperatures only a few

degrees below the freezing point of water. A specific gravity of 1.250 will permit the battery to withstand temperatures as low as - 60 F (-16 C) without freezing.

b. *charging.* The charging rate is correct when the battery maintains a minimum specific gravity of 1.250 and does not require the addition of more than 1 ounce of water per cell per week or 50 service hours.

c. *Test and Service Instructions.* (TM 9-6140-200-15).

d. *Removal and Installation.* For removal and installation, proceed as follows:

(1) Loosen thumbscrews to release battery holddown hooks.

(2) Remove battery holddowns.

(3) Lift batteries from battery box.

#### 4-51. Disconnect Switch

a. *General.* The disconnect switch is mounted on the left side of the operator's seat frame. The switch is in the electrical circuit between the negative battery terminal and the starting motor. See figure 1-3. Then the switch is turned to the OFF position, the circuit is open between the batteries and the remainder of the electrical system.

##### CAUTION

**Never turn disconnect switch OFF when engine is running or damage to the generator, regulator and lights may result.**

b. *Removal and Installation.* Refer to figure 4-44 to remove or install the disconnect. switch.

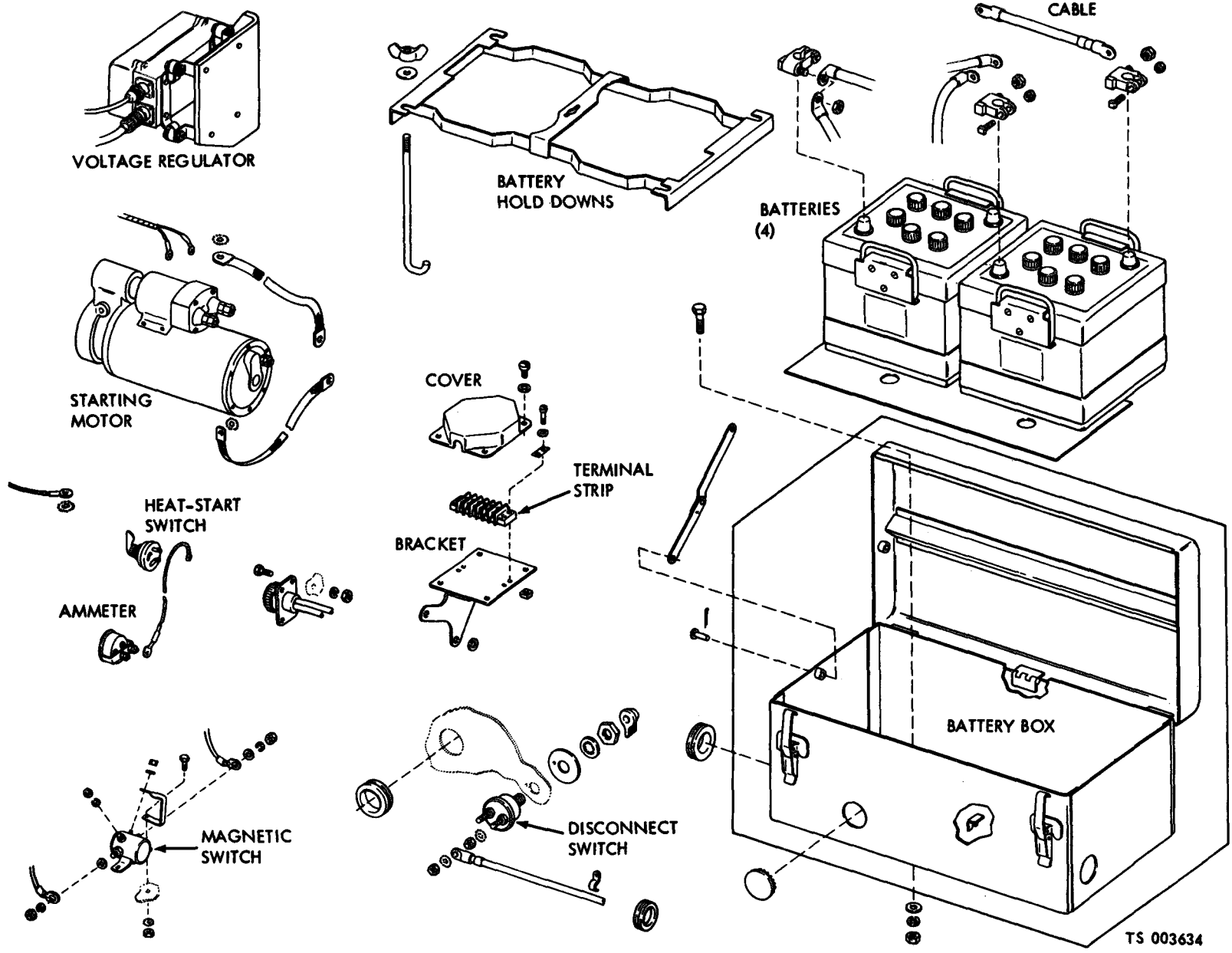

Figure 4-44. Electrical components.



## Section XIV. TRANSMISSION, TORQUE DIVIDER AND STEERING CLUTCHES

**4-52. General**

a. A common sump hydraulic system provides lubrication for the bevel gear, torque divider and transmission, cooling for the steering clutches and oil under pressure to actuate the clutches in the transmission, steering clutch hydraulic control and to charge the torque converter. The entire system is supplied by a single pump.

b. Oil is picked up by pump (17, fig. 4-45) from the sump in the bevel gear case through an oil supply tube in the transmission case (14) and flows through magnetic strainer (15) before entering the pump. The pump forces the oil under pressure through the oil filters (2) and into junction clock (7) where the oil is divided to serve the transmission hydraulic control valves (6) and the steering clutch hydraulic control (1). A bypass valve in the oil filter housing opens to permit the oil to bypass the filter elements, if the elements become clogged.

c. The portion of the oil that flows to the steering clutch hydraulic control must first flow through check valve (5). The check valve insures that there will be no quick pressure drop due to loss of engine rpm or other unforeseen emergencies.

d. The valves in steering clutch hydraulic control (1) direct oil to steering clutch pistons (13), in the steering clutch hubs, that move to disengage the steering clutches. If the valves should stick or when the steering clutches are engaged, all of the oil from junction block (7) flows through transmission hydraulic control valves. A small amount of oil is bled off through an orifice for lubrication of the control valve operating mechanism and the bevel gear shaft bearings.

e. Oil from junction block (7) that is bypassed

by transmission hydraulic control valves (6) is directed to torque converter inlet relief valve (10). Oil from the inlet relief valve is used to charge the torque converter (9) portion of the torque divider components. The torque converter inlet relief valve bypasses all oil not used by the torque converter to the transmission oil sump. The scavenge pump portion of scavenge and circulating pump (16) returns the leakage oil from torque divider housing (11) to the sump in the transmission case (14).

f. Discharge oil from torque converter (9) passes through torque converter outlet relief valve (8) to the magnetic strainer (4) and oil cooler (3) on the left side of the engine. From the oil cooler the oil flows through an elbow on scavenge and circulating pump (16) and on to transmission lubrication junction block (12) that supplies oil to the lubrication passages in the transmission. The circulating portion of scavenge and circulating pump (16) picks up oil, not needed for lubrication, at the elbow on the pump and directs it to the torque converter to aid in charging the torque converter.

**4-53. Transmission Pump***a. Removal.*

(1) Remove toolbox and bracket from right side of tractor.

(2) Remove pump as illustrated in figure 4-46. Cover the ends of the oil lines to prevent the entry of dirt.

*b. Cleaning and Inspection.*

(1) Clean pump with a clean cloth dipped in solvent.

(2) Inspect pump and drive gear for damage or defects.

(3) Replace a defective pump.

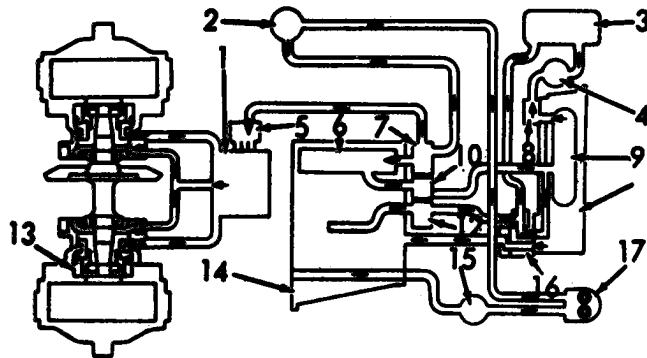

TS 003635

Figure 4-45. transmission, bevel gear, and steering clutch oil system.

KEY to figure 4-45.

1. Steering clutch hydraulic control
2. Oil filter
3. Oil cooler
4. Magnetic strainer
5. Check valve
6. Transmission hydraulic control valves
7. Junction block
8. Torque converter outlet relief valve
9. Torque converter
10. Torque converter inlet relief valve
11. Torque divider housing
12. Transmission lubrication junction block
13. Steering clutch piston
14. Transmission case
15. Magnetic strainer
16. Scavenge and circulating pump
17. Oil pump

**c. Installation.**

(1) Fill pump with clean oil and rotate the drive gear prior to installation. This will place a film of oil on the pump gears and body, and aid in priming the pump.

(2) Refer to figure 4-46 and install the pump.

(3) Inspect preformed packings and replace if necessary before connecting the hydraulic lines.

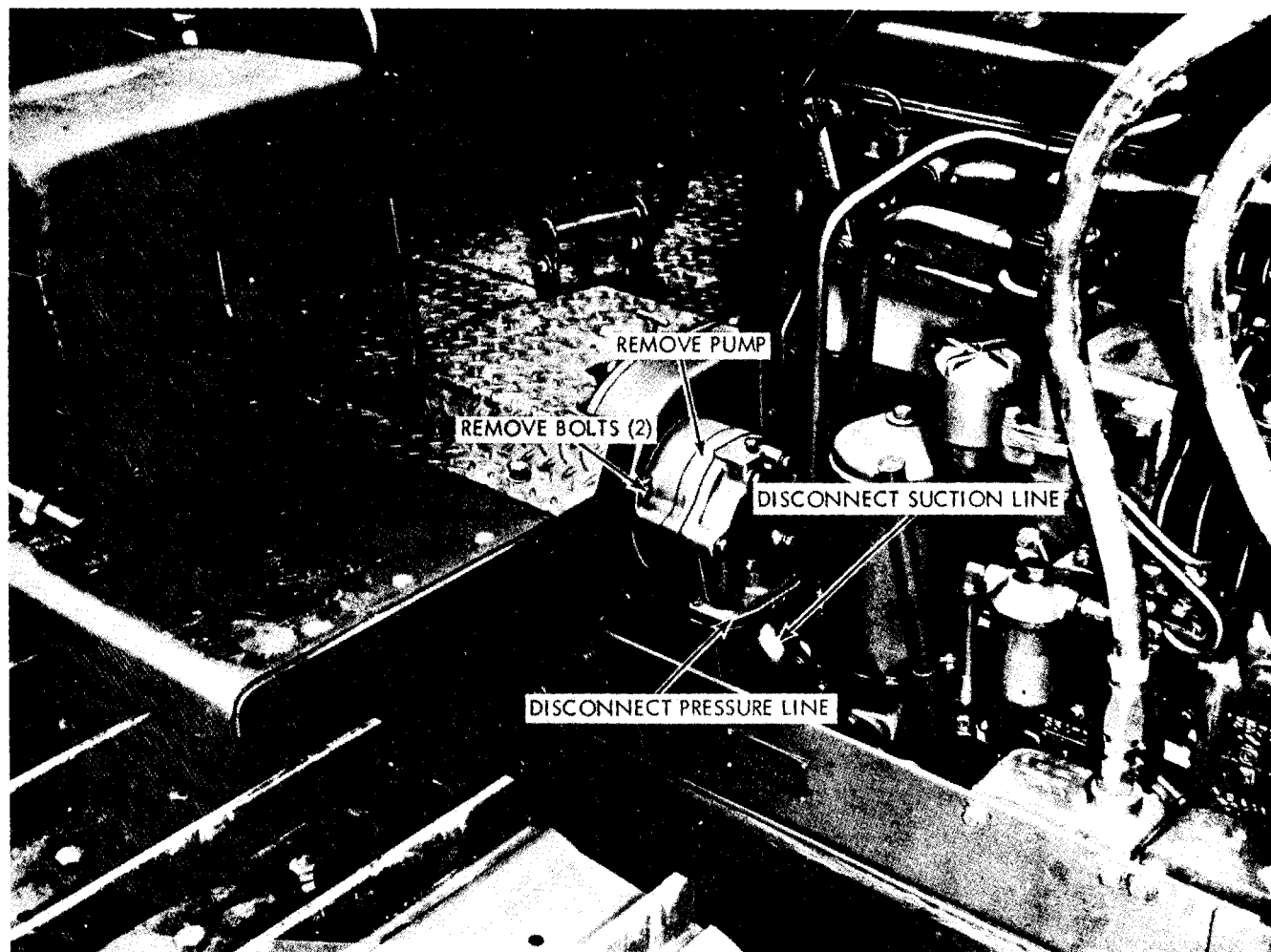

TS 003636

Figure 4-46. Transmission pump, removal and installation.

#### 4-54. Transmission Hoses, Lines, Fittings

*a. Removal.* Refer to figure 4-47 and remove hoses, tubes, or fittings as required.

*b. Cleaning and Inspection.* Clean tubes and hoses with an approved solvent. Inspect tubes

and hoses for breaks, cracks, and kinks. Inspect fittings for cracks and damaged threads. Replace defective parts.

*c. Installation.* Install as illustrated in figure 4-47.

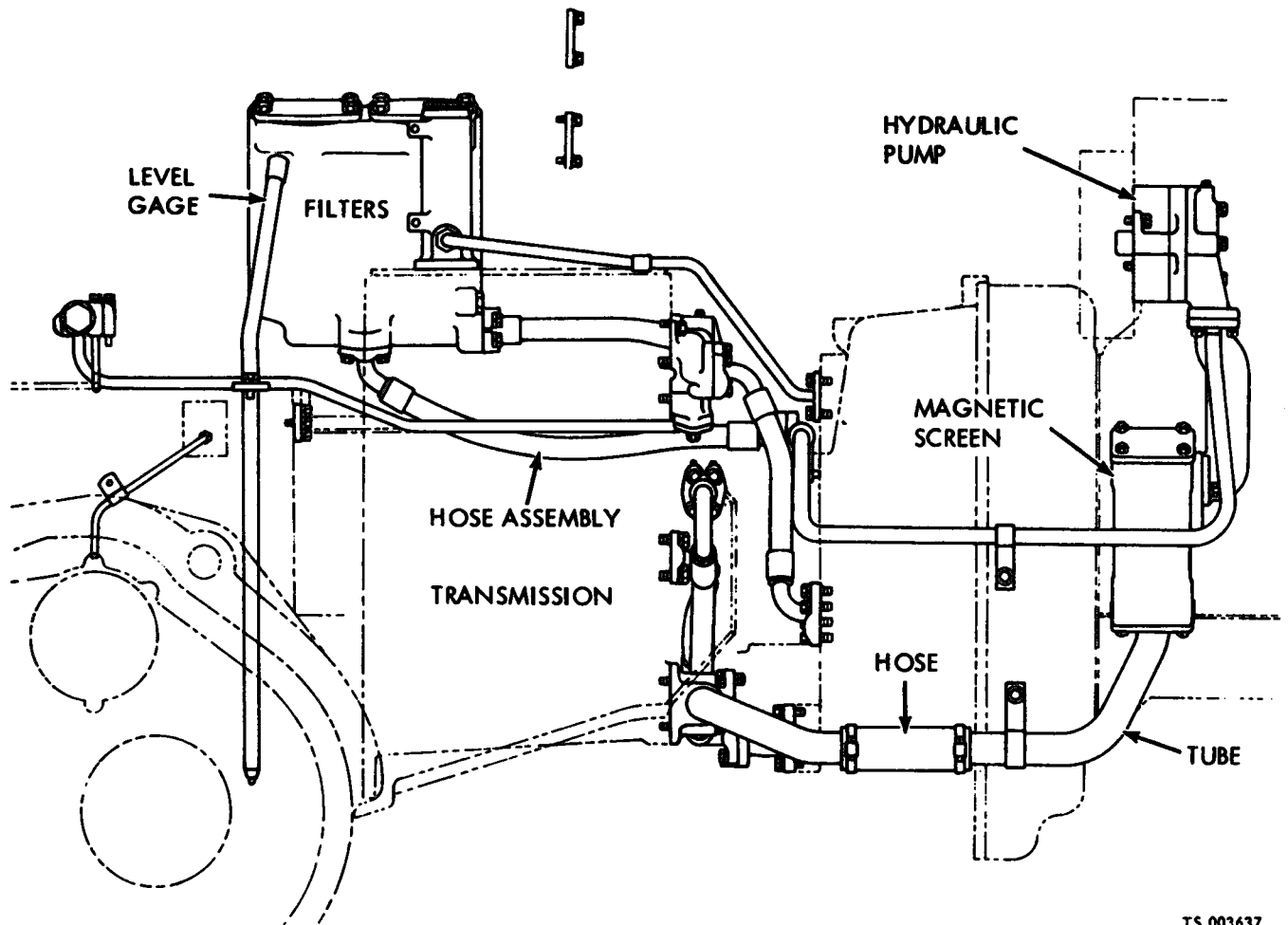

IS 003637

Figure 4-47. Transmission hoses, lines, and fitting, removal and installation (sheet 1 of 2).

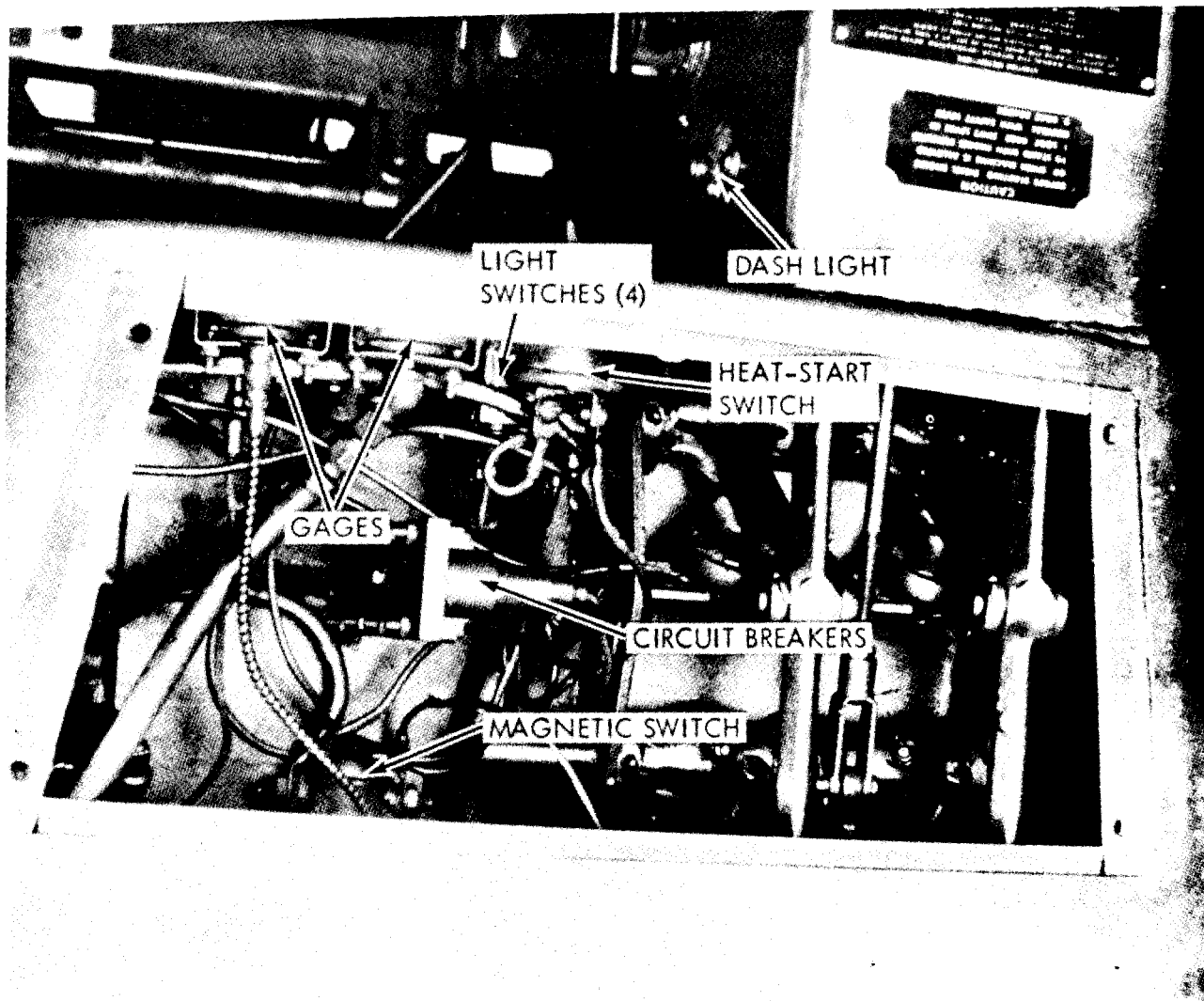

TS 003638

Figure 4-47. Transmission, hoses, lines, and fittings, removal and installation (sheet 2 of 2).

#### 4-55. Transmission Filters

*a. General.* The transmission filter housing is mounted on a bracket attached to the frame under the operator's seat.

*b. Removal and Disassembly.*

- (1) Remove seat.
- (2) Drain filter housing by removing drain plug (fig. 4-48),

(3) Refer to figure 4-48 for removal of elements and disassembly of other parts.

*c. Cleaning and Inspection.*

(1) Clean disassembled parts in an approved solvent.

(2) Inspect all parts for wear or damage.

(3) Replace defective parts.

*d. Reassembly and Installation.* Refer to figure 4-48 and reassemble and install transmission filters.

*e. Oil Check.* Start and run the engine for two minutes at low idle speed (with tractor level) to fill the filters with oil. Check the oil level and add oil as necessary.

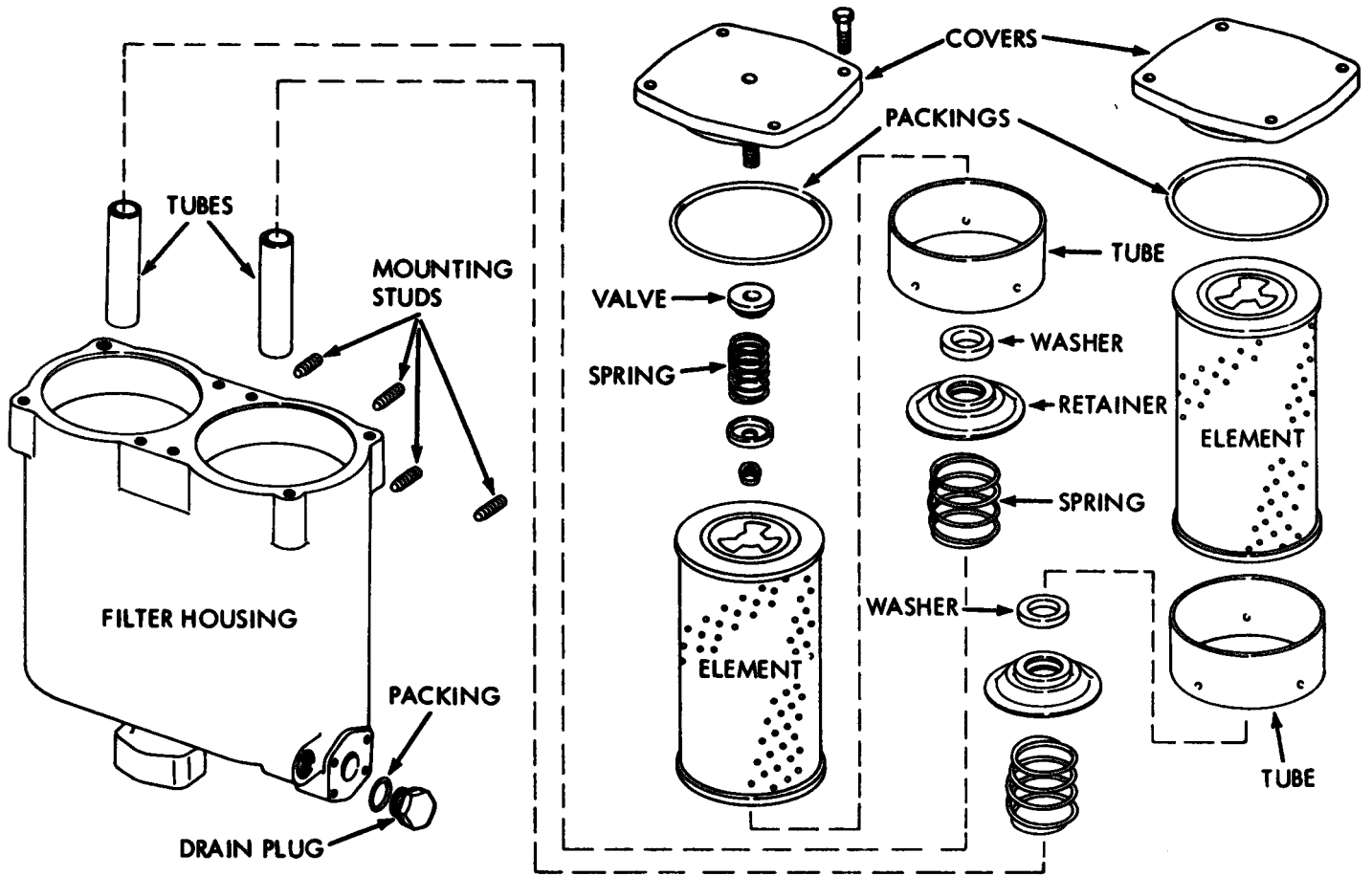

TS 003639

Figure 4-48. Transmission filters, removal and installation. (Serial nos. 76E1 through 72E1300) (sheet 1 of 2).

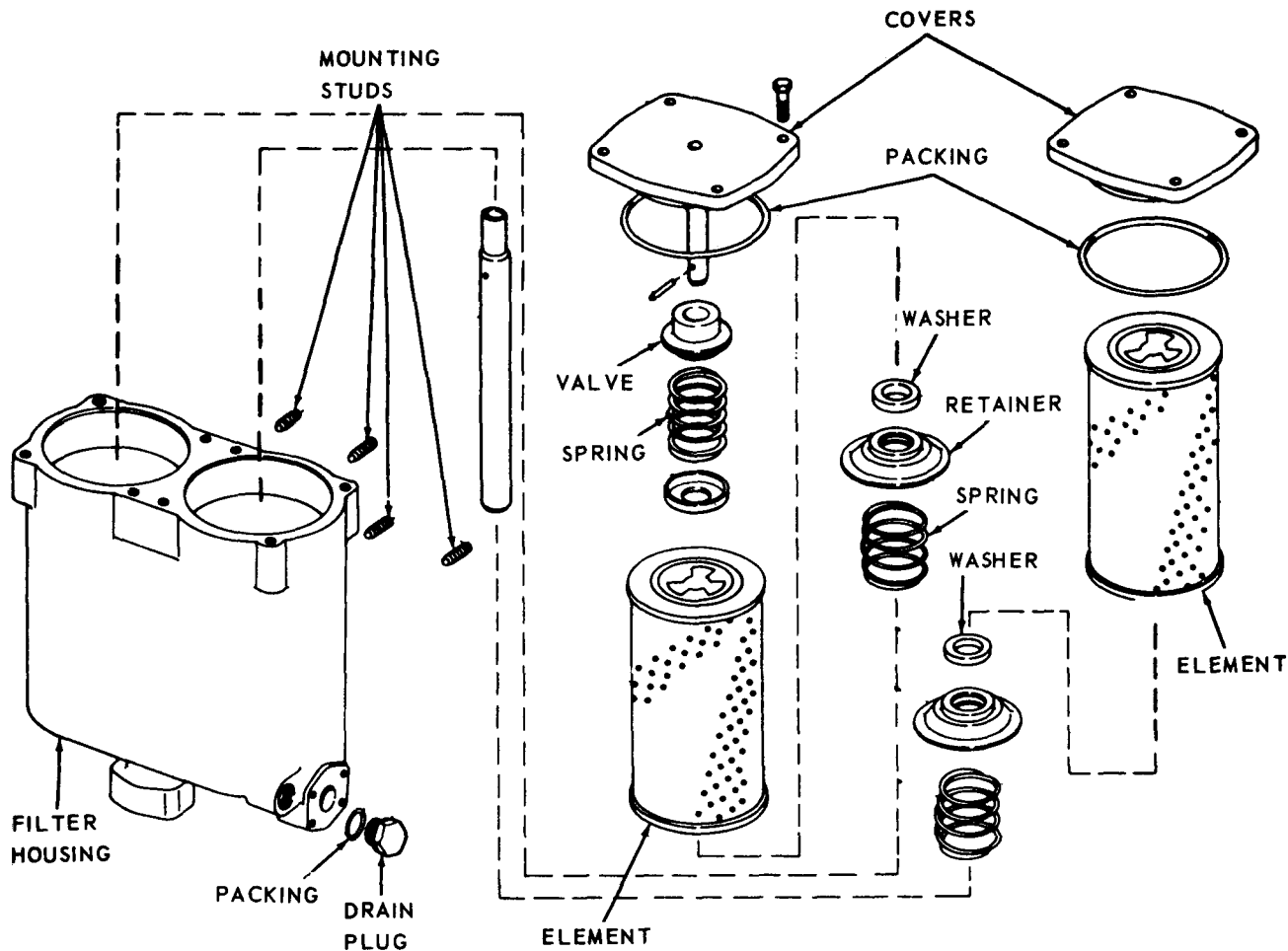

TS 003640

Figure 4-48. Transmission filters, removal and installation. (Serial nos. 75E1301 and up). (sheet 2 of 2).

## Section XV. STEERING CLUTCHES AND BRAKES

### 4-56. General

The steering clutches are hydraulically actuated and require no adjustment. There is a steering clutch linkage adjustment and a steering clutch brake adjustment.

### 4-57. Steering Clutch Brake Adjustment

Every 250 service hours check and adjust the steering clutch brakes as illustrated in figure 4-49.

a. Remove the brake adjusting screw cover, taking care not to damage the gasket.

b. With a torque wrench, turn the adjusting screw in (clockwise) until a torque of 15 lbs. ft. has been applied.

c. Turn the adjusting screw out (counterclockwise) one and one-half (1-1/2) turns to provide proper clearance between the brake lining and the brake drum.

d. Check the brake pedal for free movement.



TS 003641

Figure 4-49. Steering clutch brake adjustment.

#### 4-58. Steering Clutch Linkage Adjustment

Every 2,000 service hours refer to figure 4-50 and adjust the linkage between the control levers and the hydraulic control.

KEY to figure 4-50.

1. stop bolt
2. stop bolt locknut
3. Bumper mounting angle
4. Pin
5. Linkage lever
6. Control rod end
7. Locknut
8. Control rod

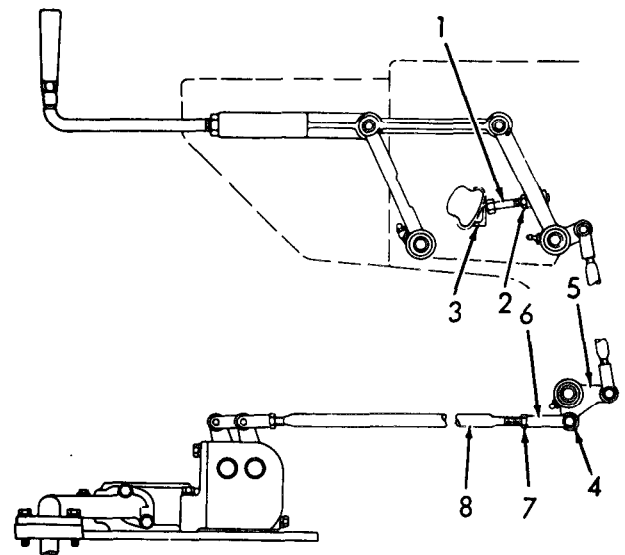

- STEP 1. REMOVE THE PINS (4) FROM THE LINKAGE LEVER (5) AND LOOSEN THE LOCKNUT (7) ON THE CONTROL ROD END (6)
- STEP 2. WITH THE STEERING CLUTCH CONTROL LEVERS IN THE FULL FORWARD POSITION, MOVE THE CONTROL RODS (8) FORWARD TO TAKE UP CLEARANCE IN THE LINKAGE. AFTER CLEARANCE IS REMOVED FROM THE LINKAGE, SPRING RESISTANCE WILL BE FELT. DO NOT MOVE THE RODS FORWARD TO THE EXTENT THAT THE SPRING IN THE STEERING CLUTCH HYDRAULIC CONTROL VALVE IS COMPRESSED
- STEP 3. ADJUST THE ROD END ON THE CONTROL ROD SO THE PIN CAN BE EASILY INSTALLED IN THE ROD END AND LINKAGE LEVER (5), THEN TURN THE ROD ENDS ONE-HALF TURN CLOCKWISE TO SHORTEN THE REACH OF THE ROD AND INSTALL THE PINS
- STEP 4. LOOSEN THE STOP BOLT LOCKNUT (2)
- STEP 5. PULL THE STEERING CLUTCH CONTROL LEVER TO THE REAR AS FAR AS IT WILL GO AND HOLD. TURN THE STOP BOLT (1) IN (CLOCKWISE) UNTIL THERE IS CLEARANCE BETWEEN THE STOP BOLT AND THE BUMPER MOUNTING ANGLE (3). AT THIS POINT THE HYDRAULIC CONTROL IS PREVENTING FURTHER MOVEMENT OF THE CONTROL LEVER. HOLD THE LEVER IN THIS POSITION UNTIL 6 IS COMPLETED
- STEP 6. TURN THE STOP BOLT OUT (COUNTERCLOCKWISE) UNTIL IT CONTACTS THE ANGLE (3) THEN TURN IT AN ADDITIONAL 1/2 TURN. RELEASE THE CONTROL LEVER AND LOCK THE STOP BOLT WITH THE LOCKNUT

TS 003642

Figure 4-50. Steering clutch linkage adjustment.



## Section XVI. FINAL DRIVES

### 4-59. Sprocket Hub Bearings

*a. General.* During the initial operation of the tractor the sprocket hub bearings are likely to require some adjustment. By maintaining the proper adjustment bearing life can be increased. They should be checked on a new tractor and adjusted if necessary after the first 125 hours of operation, another check at 250 service hours is suggested. Thereafter every 1,000 service hours should be sufficient. If leakage of lubricant is noticed around the sprocket hub on a new tractor before 125 service hours of operation an adjustment of the bearing may stop the leak.

*b. Checking Bearing Adjustment.* To check the bearing adjustment, place a four or 5-foot bar between the track roller frame and the sprocket. If any looseness in the sprocket hub bearings is noticed when prying with the bar, adjustment is necessary. This check should be made when there are no objects under the track which might put the tractor weight on the sprocket.

*c. Adjusting Sprocket Hub Bearings.* Refer to figure 4-51 and adjust bearings as instructed.

(1) Remove the guard plate from over the sprocket and the guard on the track roller frame that is just in front of the sprocket. Remove the clamp bolt (6) and lock (5) at the bottom of the holder assembly.

(2) The bearing cage retainer nut (4) should also be checked for tightness before making the bearing adjustments. Remove the cap (2) and lock (3). Loosen the adjusting nut (1) one or two turns by turning it clockwise then tighten the retaining nut (4) by using a five foot extension on the wrench. Replace the lock (3) and cap (2).

(3) Tighten the adjusting nut (1) by turning it counterclockwise. Use a five foot extension on the wrench to be sure the nut is tight.

(4) Install the lock (5) and clamp bolt (6), Replace the guard plates.

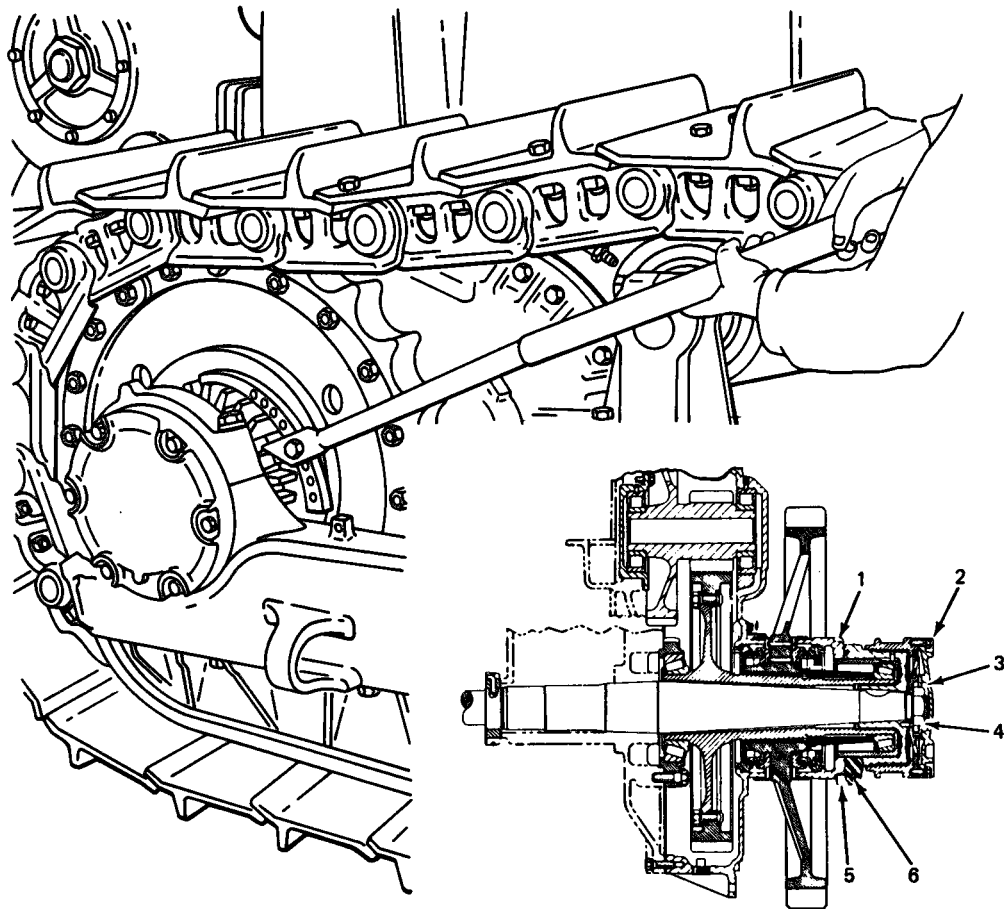

**LEGEND :**

- |                  |                 |
|------------------|-----------------|
| 1. ADJUSTING NUT | 4. RETAINER NUT |
| 2. CAP           | 5. LOCK         |
| 3. LOCK          | 6. CLAMP BOLT   |

TA 178549

*Figure 4-51. Sprocket hub bearing adjustment.*

**4-60. Washing Final Drive Compartments**

Remove drain plugs from both cases after, run when the oil is warm and allow the old oil to drain. Replace the plugs and fill the compartments to

the proper level with kerosene or clean diesel fuel. Drive the tractor back and forth for five minutes. Drain the cleaning fluid, replace the plugs and refill with fresh lubricant as specified in Lubrication Order.

## Section XVII. TRACKS AND TRACK FRAMES

### 4-61. General

*a.* The track roller frame assembly provides a mounting for track rollers, track carrier rollers, hydraulic track adjusting mechanisms, front idlers, recoil springs, and equalizer bar.

*b.* Track rollers, track carrier rollers, and front idler are lubricated with crankcase lubricating oil when assembled and do not require additional lubrication except when they have been disassembled for reconditioning.

### 4-62. Track Rollers and Idlers

Inspect track rollers and idlers for damage. Visually inspect these components as tractor is operated to be sure they are functioning properly.

### 4-63. Track Adjustment

*a. Care of Tracks.* After operating in mud or slush and if freezing temperatures are expected, park tractor on solid dry ground, planks, logs, or brush to prevent tractor from freezing to the ground. Clean snow or mud from around track links, sprockets, idlers, rollers, and guards to prevent freezing of tracks.

*b. Checking Track Adjustment.* Operate tracks without tension, to avoid undue wear of moving parts. Check track adjustment as illustrated in figure 3-11.

*c. Adjusting Tracks.*

(1) Adjust tracks as illustrated in figure 3-12.

(2) If track is too tight, release pressure (with caution) as follows:

(a) Remove all dirt, sticks, or other debris that may prevent retraction of front idler.

(b) Turn relief valve one turn counterclockwise and allow grease to escape from vent holes just below relief valve.

#### **WARNING**

**Because of high pressure, never visually inspect the relief valve or fill valve to see if grease is escaping. Always observe the track to see if it has loosened.**

(c) Tighten relief valve when more than 1½ inches of slack has developed in track.

(3) If track does not loosen after performing (a), (b), and (c), above, proceed as follows:

(a) Turn fill valve one turn counterclockwise and allow grease to escape from vent hole (fig. 3-12-).

(b) Start tractor and move backward and forward slightly.

(c) Loosen relief valve until lower hexagonal shoulder contacts underneath side of guard. This will expose unthreaded portion between upper and lower threaded sections of relief valve, allowing grease to escape through slot in lower section of threads.

(d) Loosen fill valve until hexagonal shoulder contacts underneath side of guard. This will expose unthreaded portion between upper and lower of fill valve, allowing grease to escape through slot in lower section of threads.

(e) Tighten relief valve and/or fill valve when more than 1 ½% inches slack or sag has developed in track.

(f) Adjust to obtain correct slack or sag in track.

*d.* Inspect track shoes for damage or wear. Replace defective track shoes as illustrated in figure 4-52.

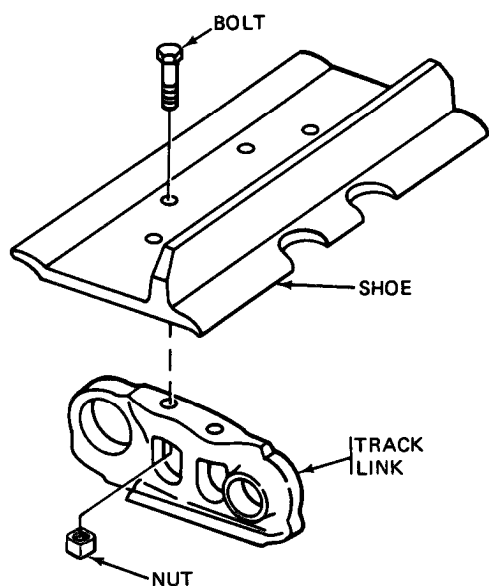

A. TRACK SHOE INSTALLATION

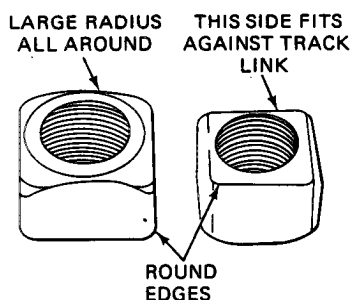

B. ILLUSTRATION OF NUT

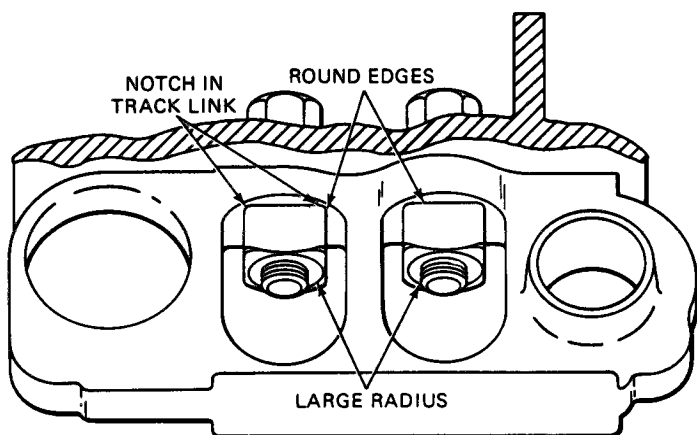

C. TRACK SHOE NUTS CORRECTLY INSTALLED

TA 178542

NOTE

1. Nuts are made with round edges on one side, and a larger radius all
2. The side with the round edges must be installed next to the track link. The round edges fit into the notch of the nut when the bolt is tightened.
3. The opposite side of nut (with the larger radius) will not fit tightly

with the side that has the largest flat surface to the track link.

Figure 4-52. Track shoe replacement.



## Section XVIII. FRAME AND GUARDS

**4-64. General**

The frame is a welded steel structure. The rear end of the frame is welded to the bevel gear case. Replacement of the frame requires complete removal of major tractor components and must be performed at depot level.

**4-65. Guards - Track Roller Frame and Sprockets**

*a. Removal.* Remove track roller frame guards and sprocket guards as illustrated in figure 4-54.

*b. Cleaning and Inspection.*

(1) Clean all parts with an approved solvent.

(2) Inspect for cracks, breaks, or other damage. Replace all defective parts.

*c. Installation.* Install guards as illustrated in figure 4-53.

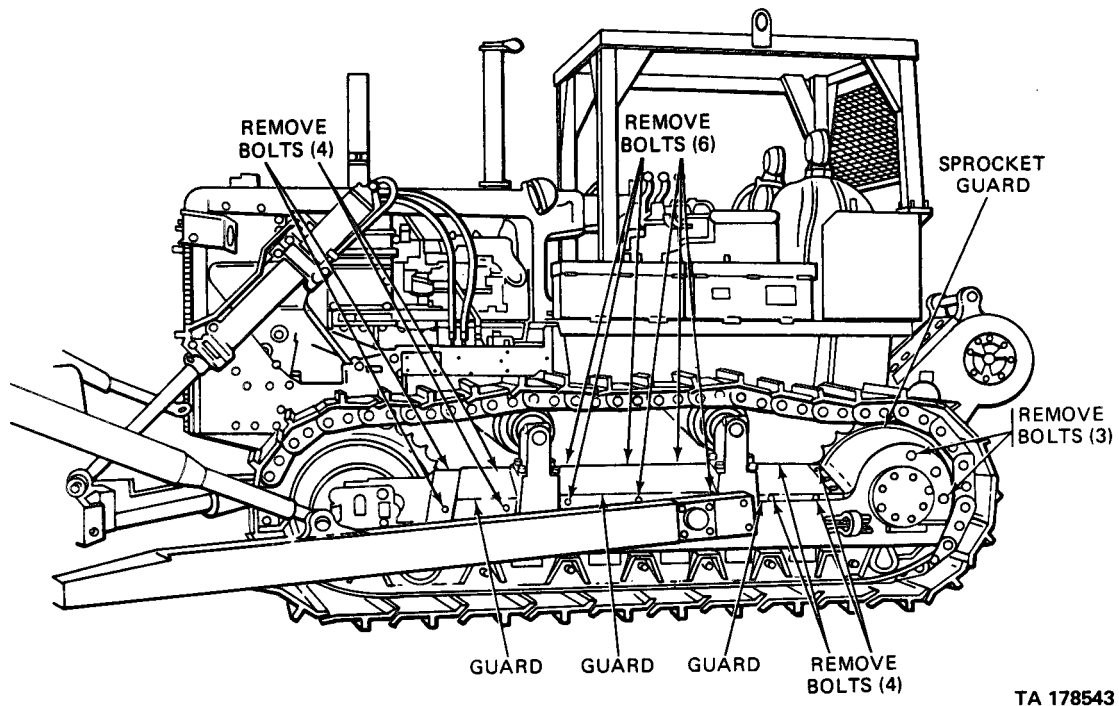

TA 178543

Figure 4-53. Guards-track roller frame and sprocket-removal and installation.

**4-66. Track Roller Guards**

a. *Removal.* Remove outer and inner guards as illustrated in figure 4-54.

b. *Cleaning and Inspection.*

(1) Clean all parts with an approved solvent and dry thoroughly.

(2) Inspect all parts for cracks, breaks, and other damage.

(3) Replace all damaged or defective parts.

c. *Installation.* Refer to figure 4-54 and install guards.

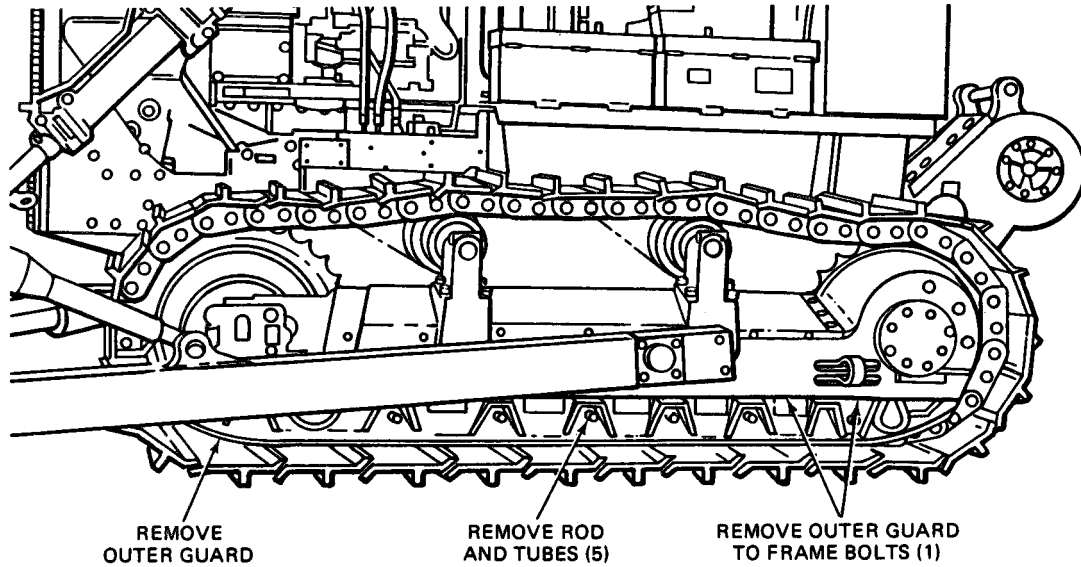

A. OUTER GUARD REMOVAL

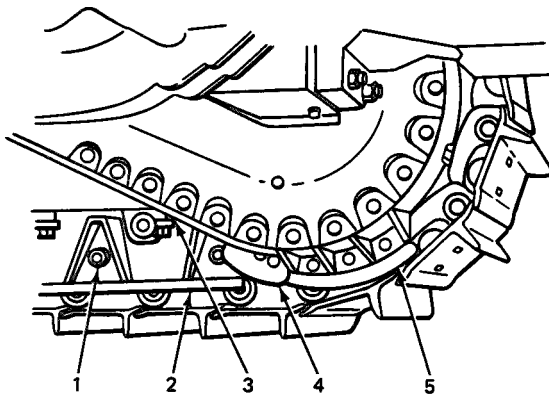

- B. INNER GUARD REMOVAL
- 1 NUTS (FIVE)
  - 2 TRACK ROLLER GUARD (INNER)
  - 3 BOLTS, WASHERS AND LOCKWASHERS, INNER GUARD-TO-FRAME (NINE EACH)
  - 4 GUARD PLATE
  - 5 GUARD PLATE

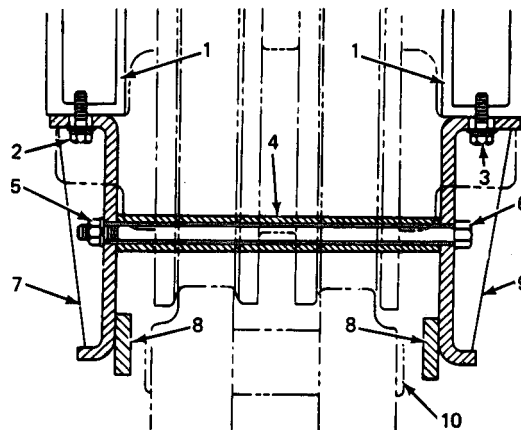

- C. TRACKROLLER GUARDS INSTALLED (REARVIEW)
- 1 TRACK ROLLER FRAME
  - 2 BOLTS, WASHERS AND LOCKWASHERS, INNER GUARD-TO-FRAME (NINE EACH)
  - 3 BOLTS, WASHERS AND LOCKWASHERS, OUTER GUARD-TO-FRAME (ELEVEN EACH)
  - 4 TUBE (FIVE)
  - 5 NUTS AND LOCKWASHERS (FIVE EACH)
  - 6 RODS (FIVE)
  - 7 TRACK ROLLER GUARD (INNER)
  - 8 WEAR STRIPS
  - 9 TRACK ROLLER GUARD (OUTER)
  - 10 TRACK PINS
- TA 176519

Figure 4-54. Track roller guards, removal and installation.





**4-67. Crankcase Guards**

*a. Removal*

(1) Support front guard (approx. 300 lb.) and remove as illustrated in figure 4-55.

(2) Support rear guard (approx 280 lb) and remove as illustrated in figure 4-55.

*b. Cleaning and Inspection.*

(1) Clean all parts with an approved solvent.

(2) Inspect guards for cracks, breaks, or other damage.

(3) Inspect threaded parts for damaged threads.

(4) Replace defective parts.

*c. Installation.* Refer to figure 4-55 and install guards in reverse order of removal.

**4-68. Engine Upper Guard Assemblies**

*a. Removal.* Refer to figure 4-56 and remove engine upper guard assemblies. Remove door assembly and left hand rear guard as a unit.

*b. Cleaning and Inspection.*

(1) Clean guard assemblies with an approved solvent.

(2) Inspect guards for breaks, cracks, or damage,

(3) Inspect threaded parts for damage. Chase threads with an appropriate tap or die if necessary.

*c. Installation.* Install in reverse order of removal.

**CAUTION**

**Do not use tractor in land clearing operation unless equipped with engine protection kit, part number 3R6740.**

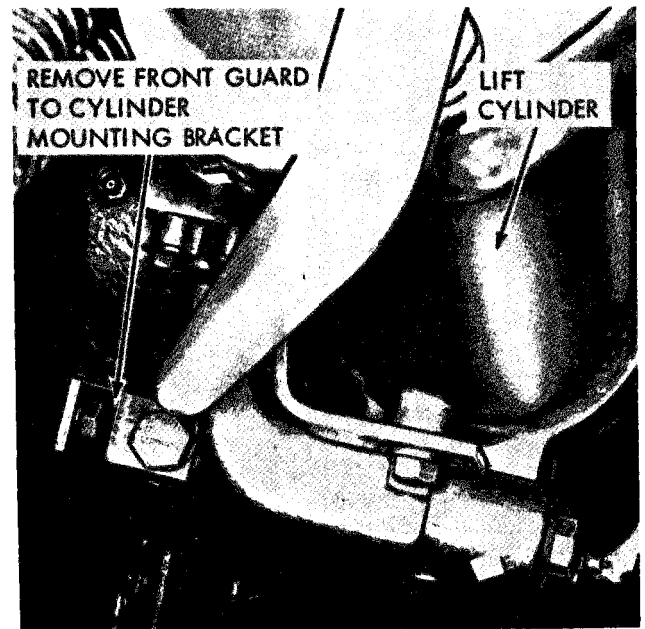
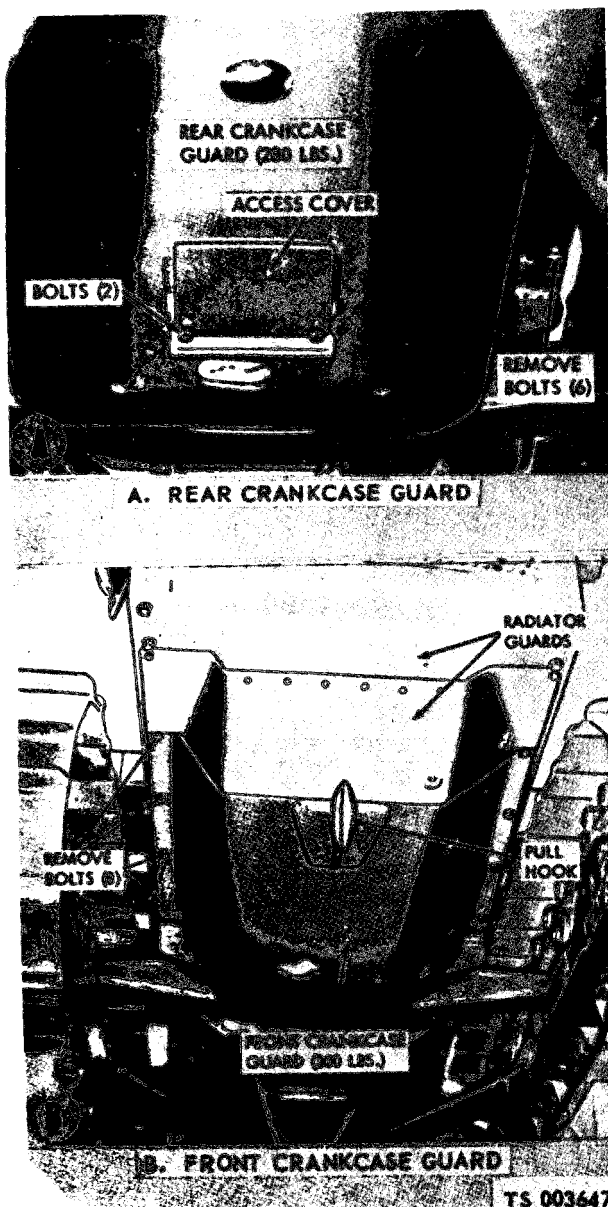

Figure 4-56. Engine upper guard assemblies, removal and installation (sheet 1 of 3).

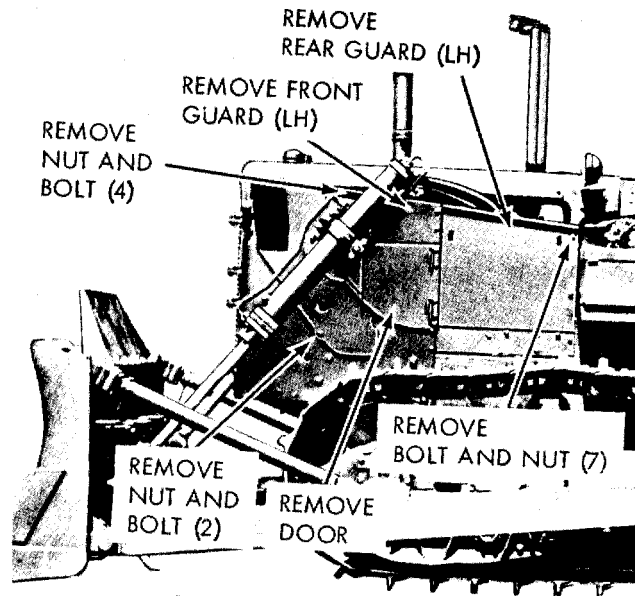
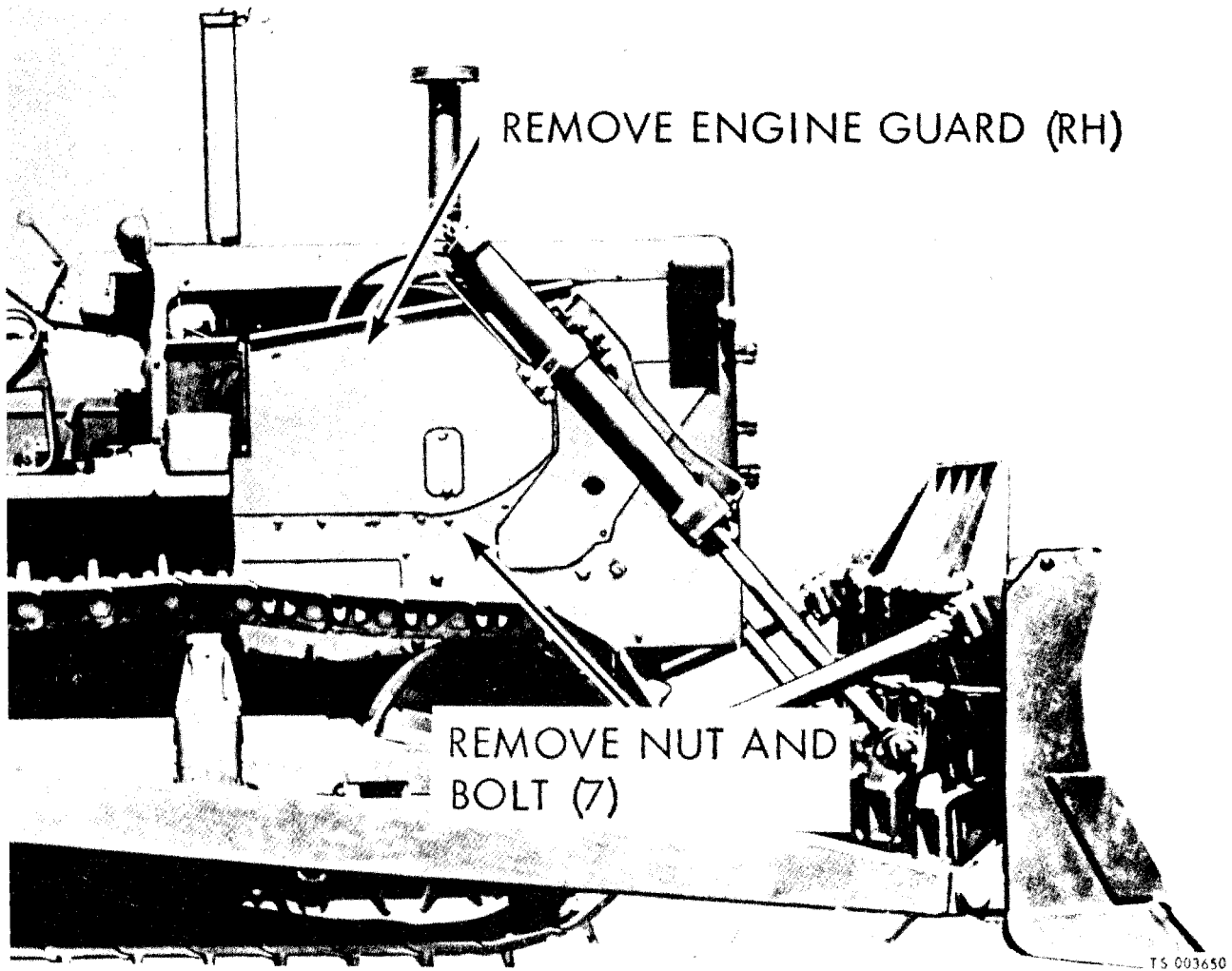

Figure 4-56. Engine upper guard assemblies, removal and installation (sheet 2 of 3).



## Section XIX. BODY, HOOD, AND HULL

**4-69. Fenders***a. Removal.*

(1) The right fender supports the dozer hydraulic tank, and the tank must be removed prior to fender removal. Refer to direct support maintenance.

(2) The left fender supports the battery and battery boxes. Remove battery and battery boxes. After removal of battery boxes, remove fender attaching bolts and remove fender.

*b. Cleaning and Inspection.*

(1) Clean fenders with an approved cleaning solvent.

(2) Inspect fenders for breaks, cracks, corrosion.

(3) Inspect threaded parts for damaged or stripped threads.

(4) Replace defective parts.

*c. Installation.* Installation is opposite of removal.

**4-70. Floors**

*a. Removal.* Remove and disassemble floor plates and supports as illustrated in figure in figure 4-57.

*b. Cleaning and Inspection.*

(1) Clean all parts with an approved solvent and dry thoroughly.

(2) Inspect for cracks, breaks, or other damage. Replace defective parts.

*c. Installation.* Reassemble and install floor plates and supports as illustrated in figure 4-57.

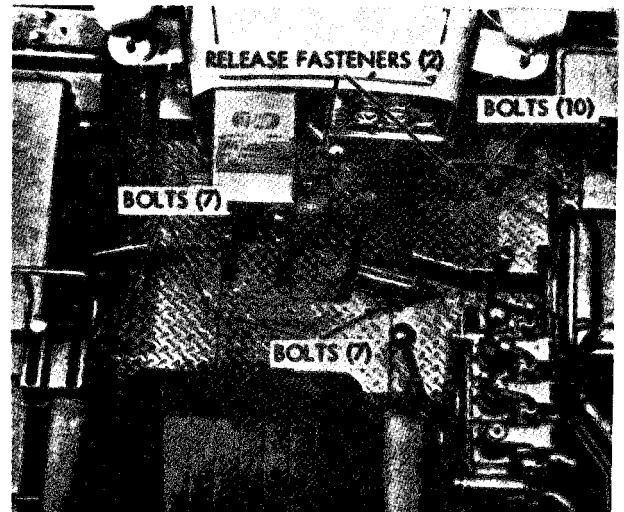

TS 003651

Figure 4-57. Floor plates, removal and installation.

**4-71. Toolbox**

*a. Removal.* Remove toolbox as illustrated in figure 4-58.

*b. Cleaning and Inspection.*

(1) Clean all parts with an approved solvent and dry thoroughly.

(2) Inspect for cracks, breaks, or other damage. Replace defective parts.

*c. Installation.* Install toolbox as illustrated in figure 4-58.

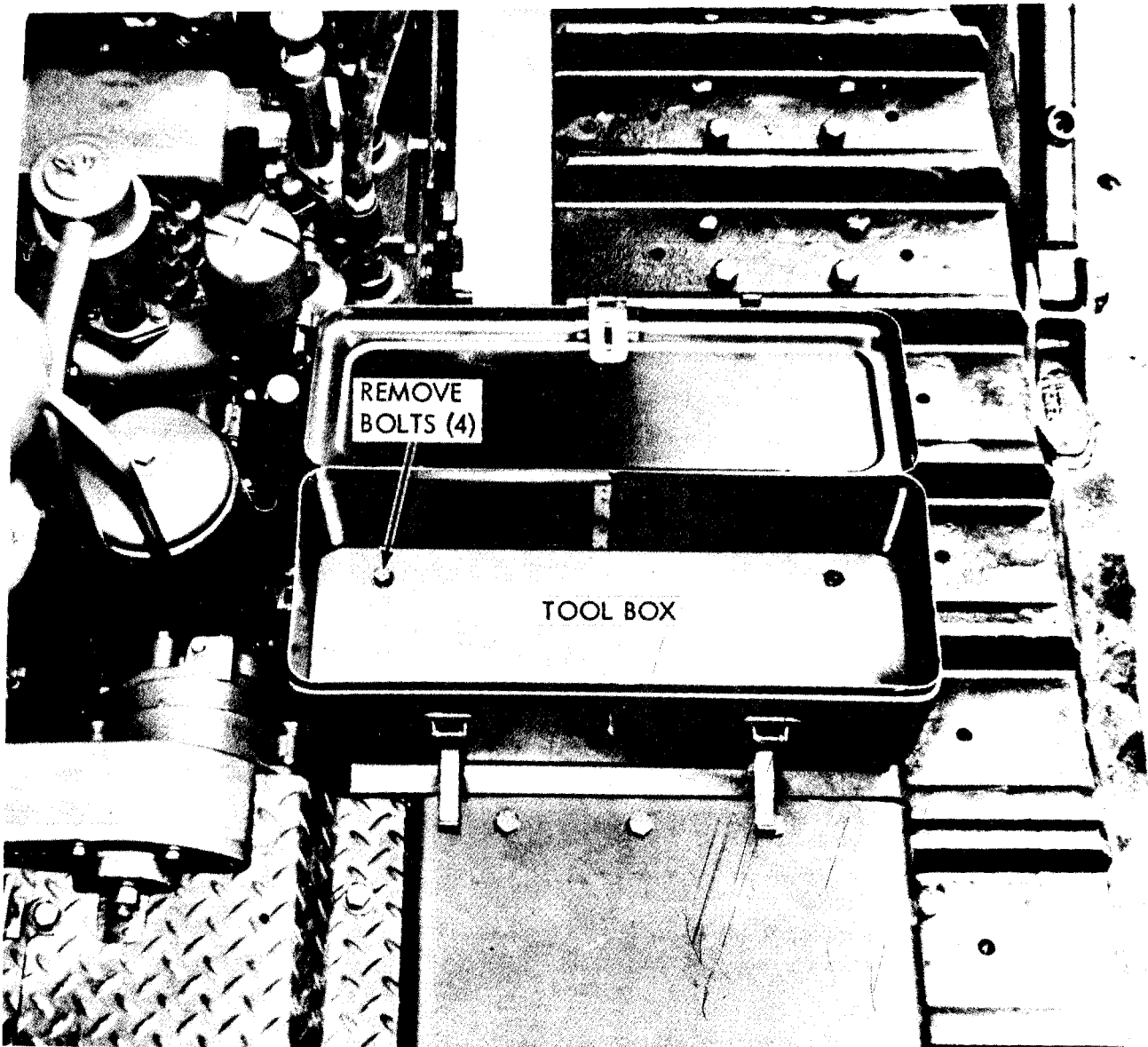

TS 003652

Figure 4-58. Toolbox, removal and installation.

#### 4-72. Seat

*a. General.* Seats are covered with a durable, weather resistant material. Care should be taken to avoid damaging the cushions with sharp or heavy objects, unnecessary exposure, battery acids, oil, or grease.

*b. Removal and Disassembly.* Remove the seat as illustrated in figure 4-59.

#### *c. Cleaning and Inspection.*

(1) Clean cushions with an approved cleaner. Dry with a clean cloth.

(2) Inspect cushions for tears or deterioration.

(3) Replace defective parts

*d. Reassembly and Installation.* Refer to figure 4-59, reassemble and install seat.

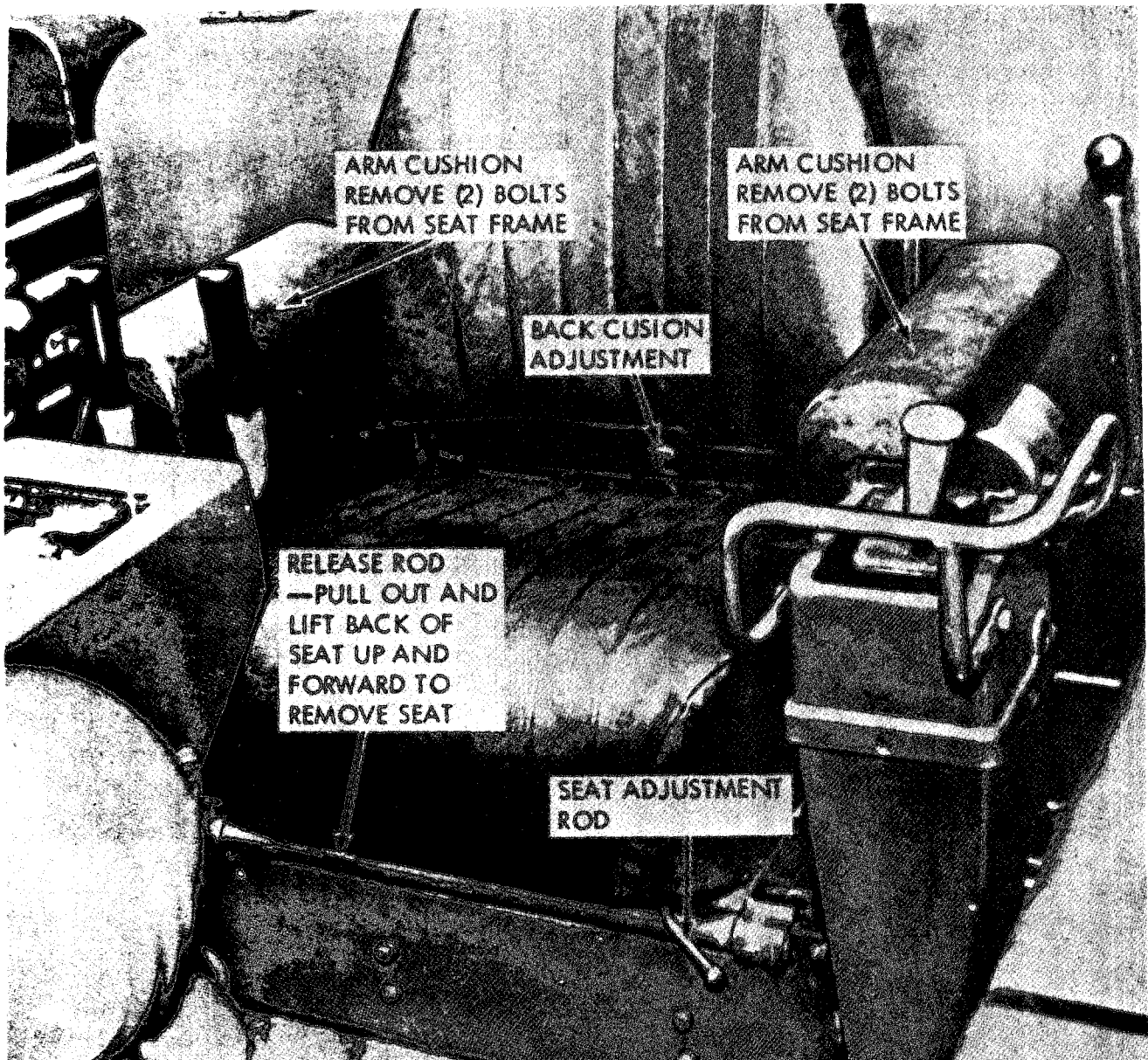

TS 003653

Figure 4-59. Seat, removal and installation.

## Section XX. BULLDOZER AND SCARIFIERS

### 4-73. General

The bulldozer group includes the bulldozer blade assembly, braces, push arm assemblies, and trunnions. The bulldozer blade assembly includes the moldboard, cutting edge, and end bits. Scarifiers are mounted on the back of the moldboard. The bulldozer hydraulic system

(Section XXI) furnishes lift and tilt control for the bulldozer.

### 4-74. Bulldozer Blade Assembly

a. *Removal.* Refer to figure 4-60 and remove blade assembly.

b. *Disassembly.* Remove end bits, cutting edges, and scarifiers from moldboard.

c. *Cleaning, Inspection, and Repair.*

(1) Clean all parts thoroughly with an approved solvent.

(2) Inspect all parts for breaks, cracks, distortion, and wear.

(3) Inspect all threaded parts for damaged threads.

(4) Repair or replace any defective parts.

d. *Reassembly and Installation.* Refer to figure 4-60, reassemble and install blade.

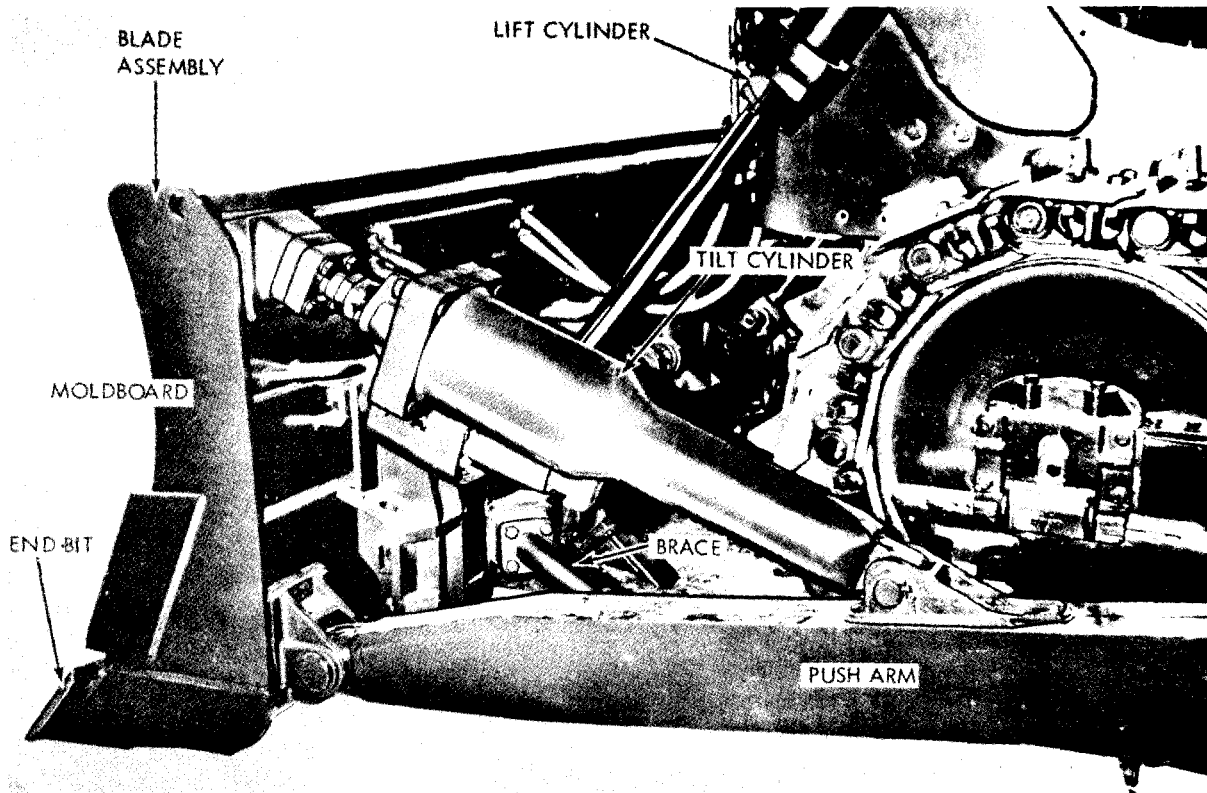

- STEP 1. POSITION THE BLADE ASSEMBLY ON BLOCKING TO PROVIDE EASY ACCESS FOR REMOVAL OF SCARIFIERS, END BITS, AND CUTTING EDGE.
- STEP 2. DISCONNECT LIFT CYLINDER RODS FROM MOLDBOARD.
- STEP 3. SUPPORT TILT CYLINDER WITH HOIST OR BLOCKING AND REMOVE FROM MOLDBOARD.
- STEP 4. REMOVE BRACES.
- STEP 5. DISCONNECT PUSH ARM AND REMOVE BLADE.

TS 003454

Figure 4-60. Bulldozer blade assembly, removal and installation.

#### 4-75. Push Arms

a. *Removal.* Remove push arms as instructed in figure 4-61.

b. *Cleaning, Inspection, and Repair.*

(1) Clean all parts thoroughly with an approved solvent.

(2) Inspect for breaks, cracks, corrosion, or damage.

(3) Inspect threaded parts for damaged or stripped threads.

(4) Inspect trunnion cap for wear.

(5) Replace any defective parts.

c. *Installation.* Refer to figure 4-61 and install in reverse order of removal.

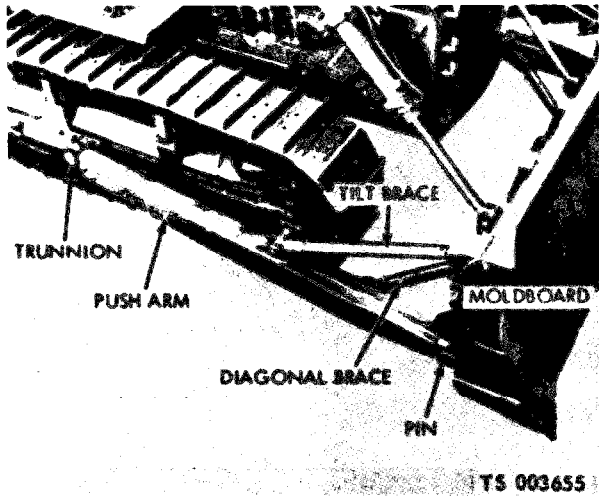

Figure 4-61. Push arms, removal and installation.

#### 4-76. Scarifiers

a. *Removal.* Refer to paragraph 3-18 for removal of scarifier shanks. Remove scarifier housings as instructed in figure 4-62.

b. *Cleaning, Inspection, and Repair.*

(1) Clean housings thoroughly with an approved solvent.

(2) Inspect for cracks, distortion, or wear.

(3) Replace defective housings or hardware.

c. *Installation.* Refer to figure 4-62 and install in reverse order of removal.



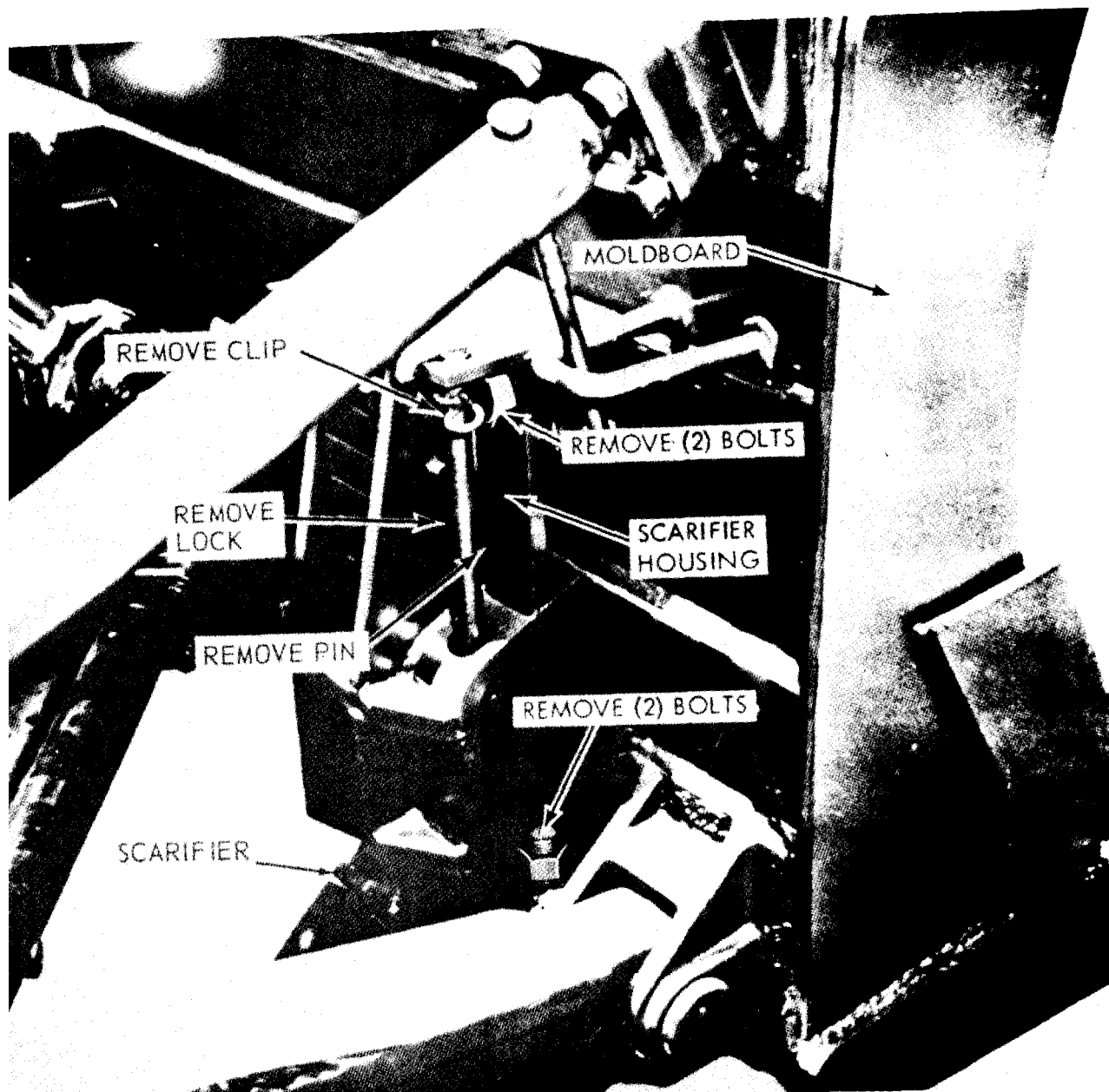

TS 003656

Figure 4-62. Scarifier housing, removal and installation

## Section XXI. HYDRAULIC SYSTEM - BULLDOZER

### 4-77. General

The hydraulic system includes a gear type pump mounted on the engine accessory power takeoff, hydraulic tank and valve assembly mounted on the right fender, two lift cylinders and one tilt cylinder for the moldboard, and hydraulic lines. The filter and two valves are located inside the

hydraulic tank. One valve controls the lift cylinders and the other controls the tilt cylinder. A separate three lever valve for control of a rear attachment, such as operator's seat.

### 4.78. Dozer Hydraulic Pump

#### a. Removal.

- (1) Drain hydraulic tank.
- (2) Remove floor boards covering pump and lines.
- (3) Clean pump, lines attaching, and areas where pump is mounted on power takeoff.
- (4) Remove pump as illustrated in figure 4-63.
- (5) Cover pump openings to prevent dirt from entering.

*b. Cleaning and Inspection.*

- (1) Clean exterior of pump with an approved solvent.
- (2) Inspect pump drive gear for excessive wear or damage.
- (3) **Inspect exterior of pump for cracks.**
- (4) **Replace pump if gear or pump are defective.**

*c. Installation.*

- (1) Refer to figure 4-63 and install pump.
- (2) Refill hydraulic tank.

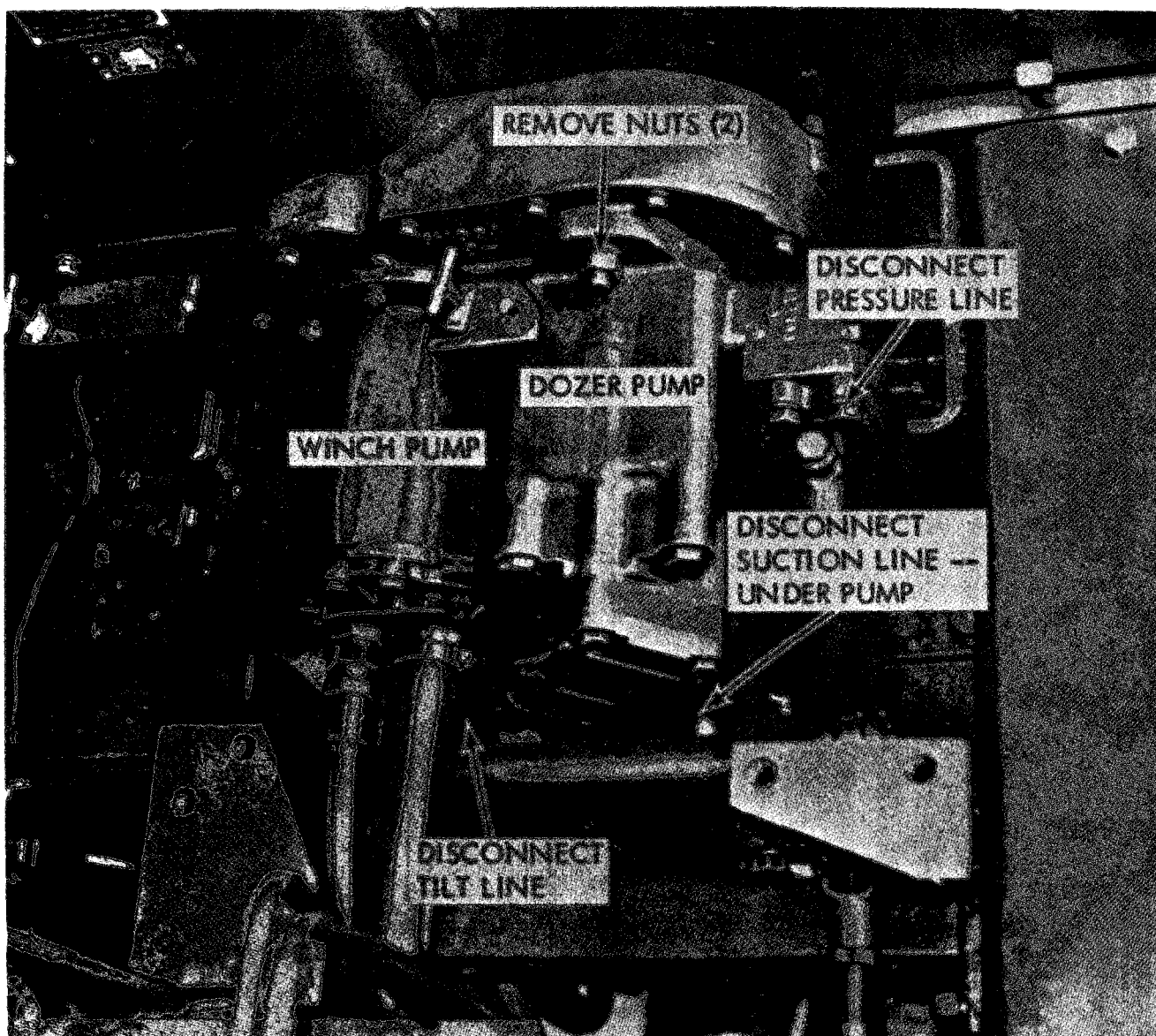

TS 003657

Figure 4-63. Dozer hydraulic pump, removal and installation.

4-79. Hydraulic System Hoses, Lines, Fittings

*a. Removal.* Refer to figure 4-64 for removal of hydraulic hoses, lines, and fittings.

*b. Cleaning and Inspection.* Clean tubes and hoses with an approved cleaning solvent. Inspect

tubes and hoses for breaks, cracks, and kinks. Inspect fittings for cracks and damaged threads. Replace defective parts.

*c. Installation.* Install in reverse order of removal.

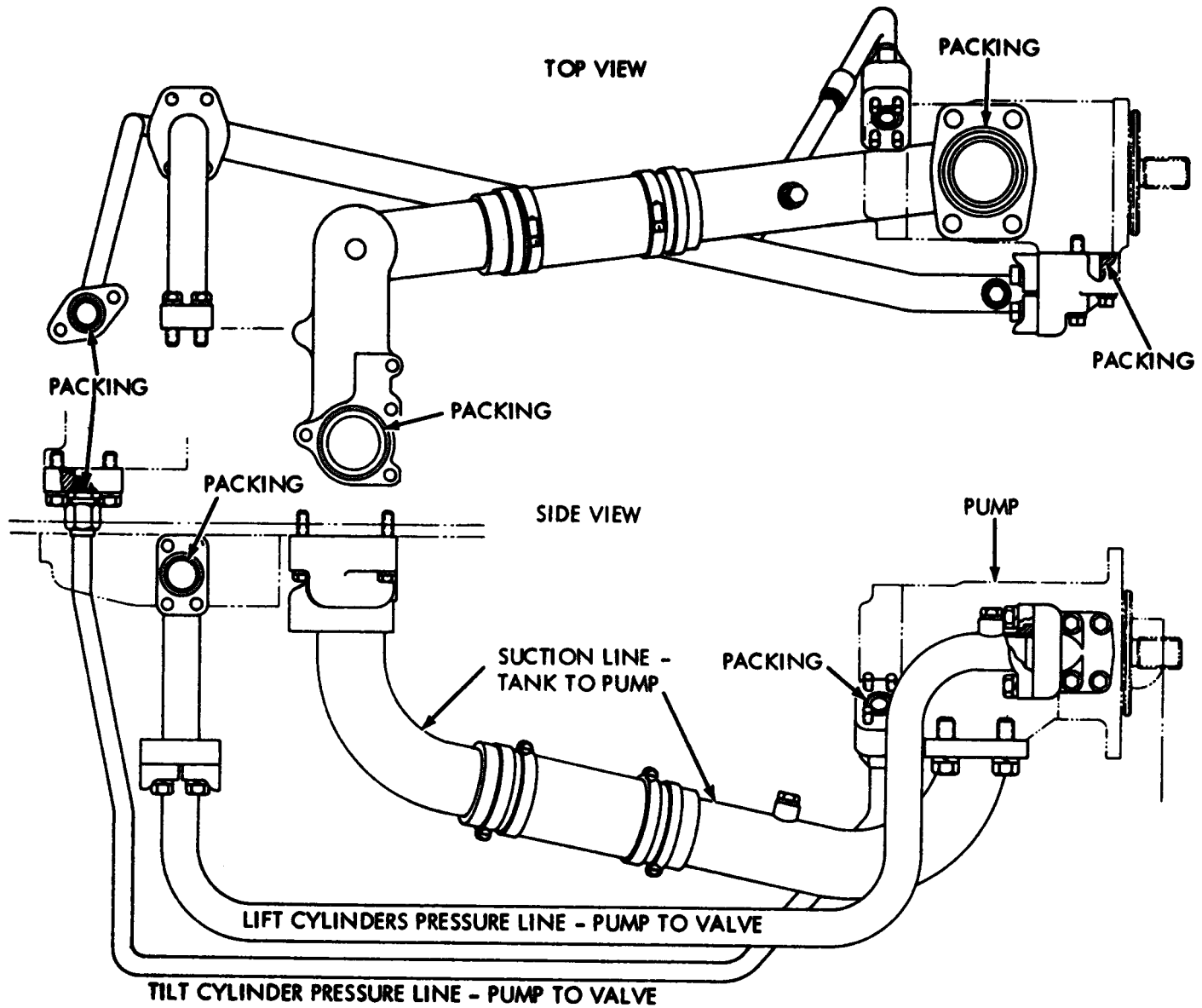

TS 003658

Figure 4-64. Hydraulic system hoses, lines, and fittings, removal and installation. (sheet 1 of 4).

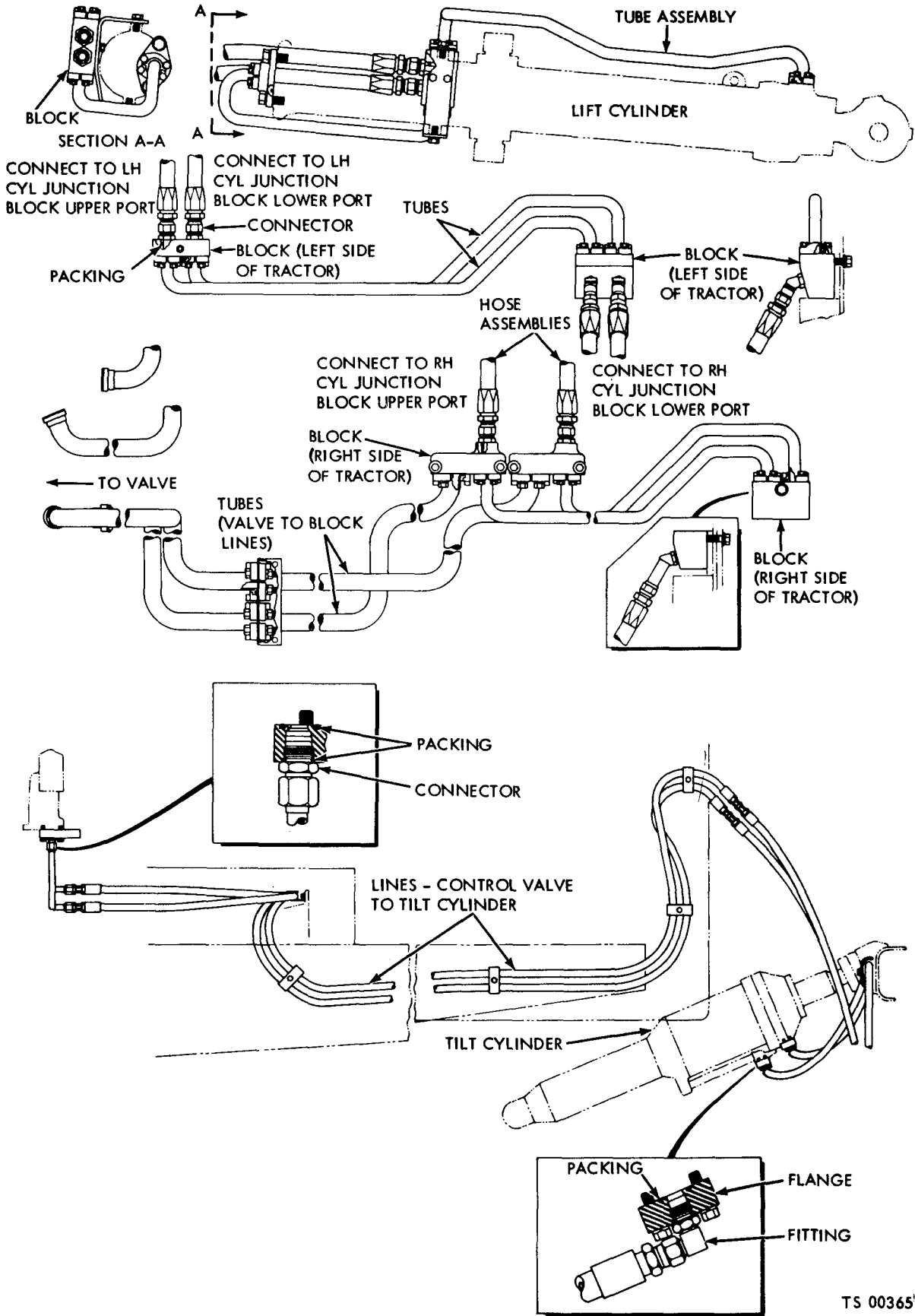

TS 00365'9

Figure 4-64. Hydraulic system hoses, lines, and fittings, removal and installation. (sheet 2 of 4).

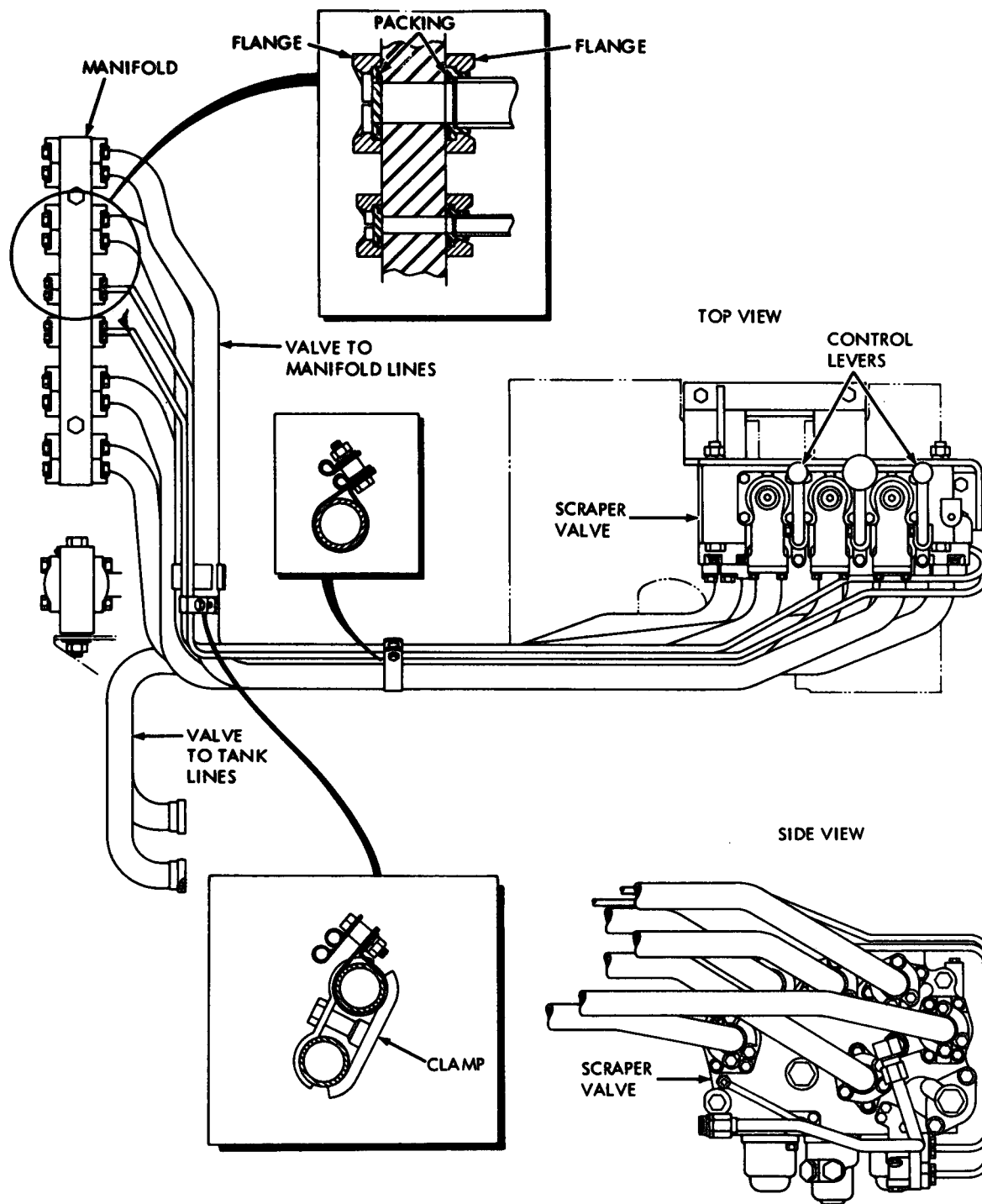

TS 003660

Figure 4-64. Hydraulic system hoses, lines, and fittings, removal and installation. (sheet 3 of 4).

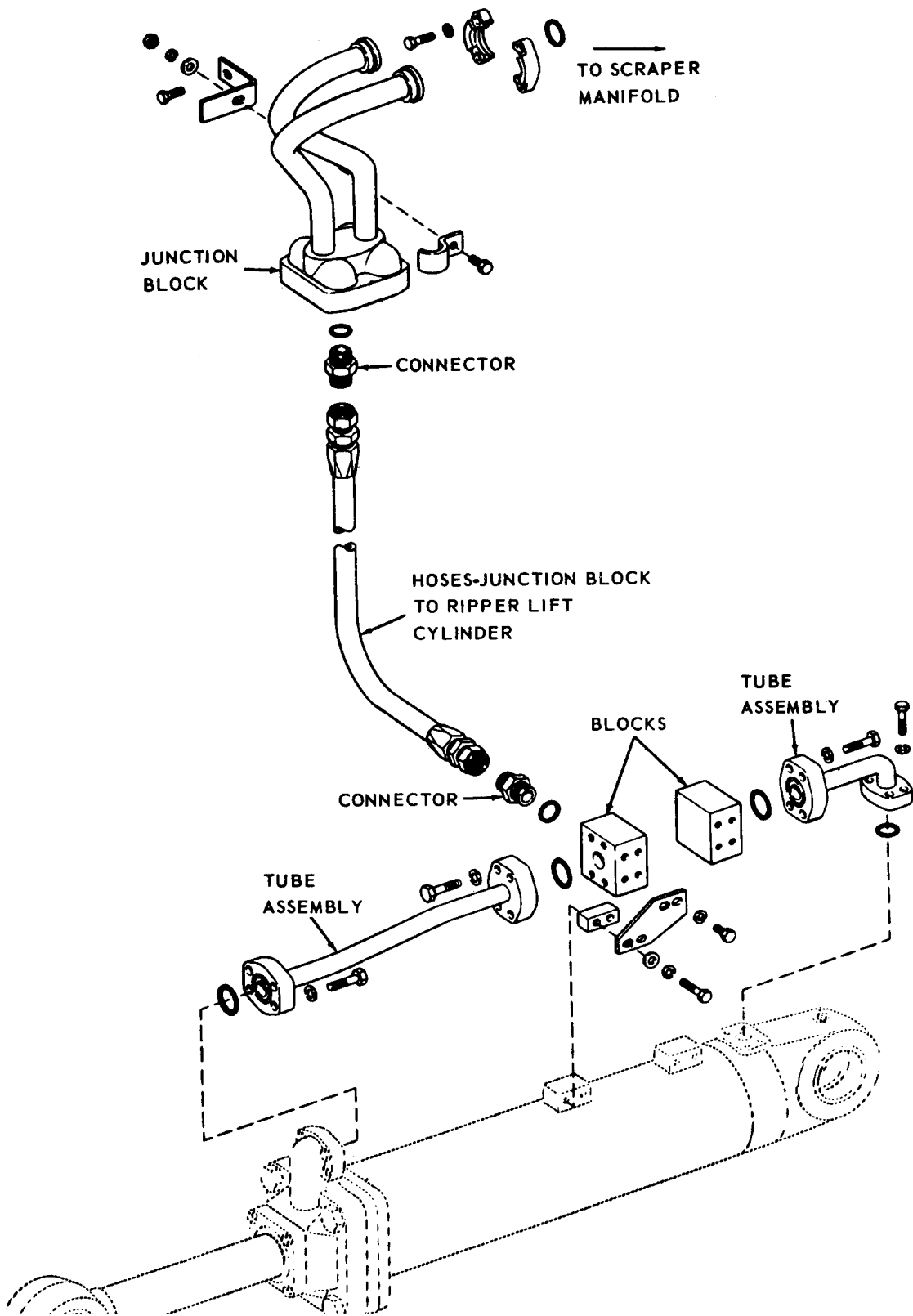

TS 003661

Figure 4-64. Hydraulic system hoses, lines, and fittings, removal and installation. (sheet 4 of 4).

#### 4-80. Dozer Hydraulic Tank and Filter

*a. General* The dozer hydraulic tank is mounted on the right fender at the rear of the tractor. The filter is installed in the tank and can be removed by removing the cover at the top. The tank has a drain valve and drain hose at the rear. The guard at bottom of tank must be removed for access to the drain valve.

##### *b. Filter.*

(1) *General.* The single element full-flow filter is a part of the hydraulic tank. All return oil from the tilt and lift cylinders and scraper circuits flows through the filter. A spring loaded bypass valve is located in the filter cover assembly (fig. 4-65). If the filter element becomes clogged or restricted, the resulting buildup of oil pressure will exert a force on top of the bypass valve causing it to move down against the force of the spring allowing the oil to bypass the filter element. Air bleed plugs in the cover are used to bleed air from the hydraulic system when the system is being filled.

(2) Filter cover assembly removal. Loosen bolt (A, fig. 4-65) and remove cover assembly.

(3) Filter cover assembly disassembly (B, fig. 4-65).

(a) Push down on retainer and remove cotter pin.

(b) Disassemble parts as shown.

(4) *Filter cover assembly cleaning and inspection.*

(a) Clean all parts with an approved cleaning solvent and dry thoroughly.

(b) Inspect parts for cracks, breaks, or other damage.

(c) Replace all damaged or defective parts.

(5) *Reassembly.* Reassemble filter cover assembly in reverse order of disassembly.

*c. Dozer Hydraulic System Service.* Drain and refill the dozer hydraulic system as instructed in lubrication order.

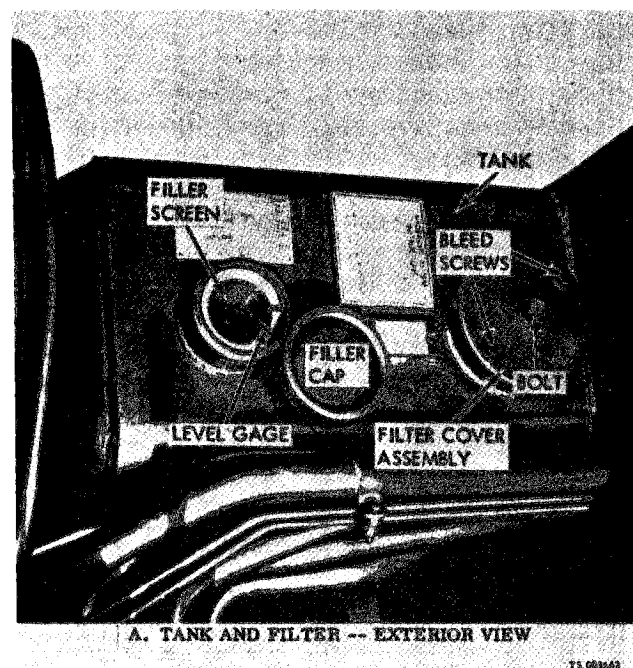
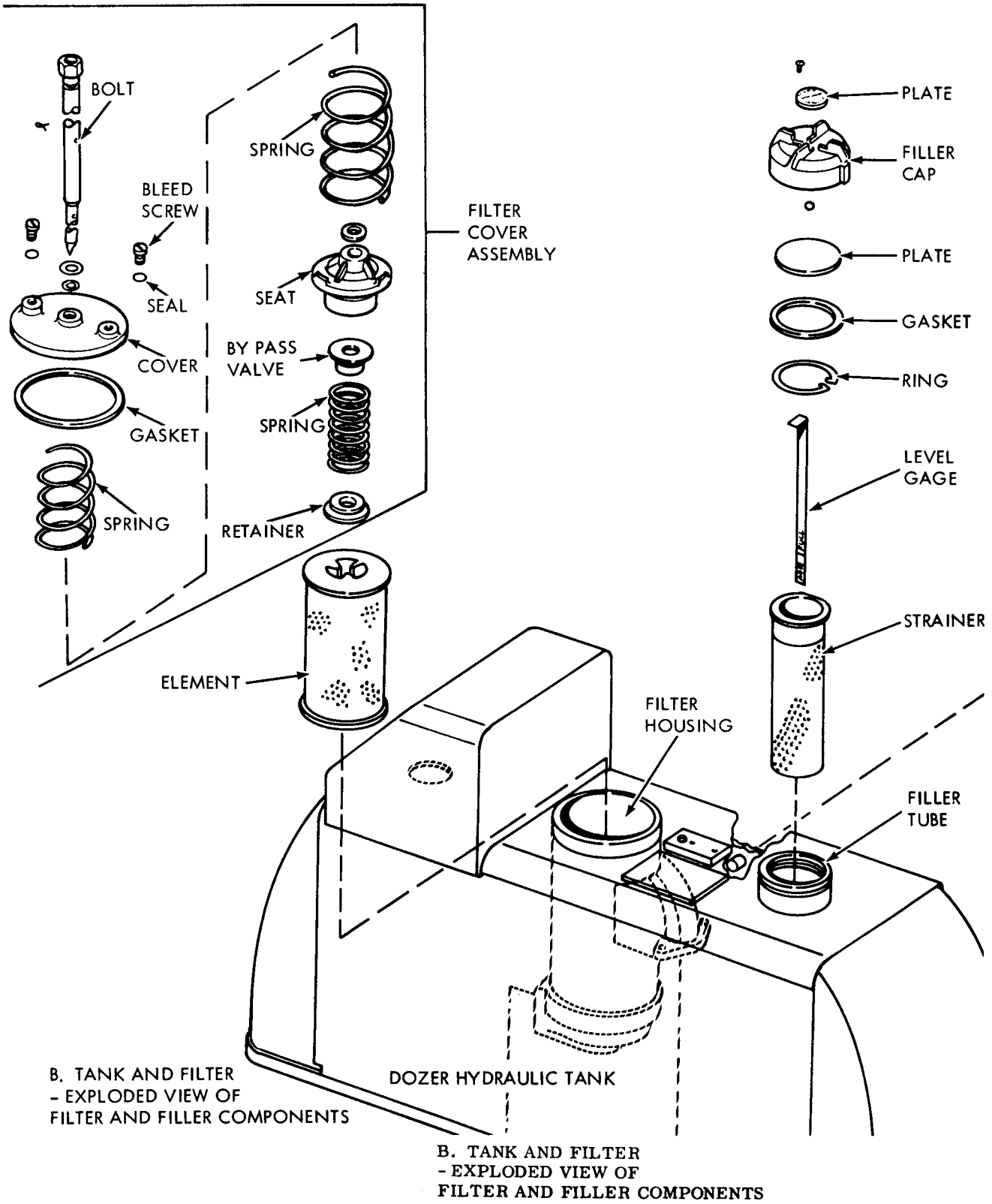

Figure 4-65. Dozer hydraulic system tank and filter. (sheet 1 of 2).





TS 003663

Figure 4-65. Dozer hydraulic system tank and filter. (sheet 2 of 2).

**4-81. Hydraulic Control Lever and Linkage**

The hydraulic control levers are secured to the floor plates to the right of the operator. The linkages to connect the levers to the control valves are located beneath the floor plates (fig. 4-66).

*a. Removal.*

- (1) Remove the operator's seat.
- (2) Remove the fire extinguisher and its mounting bracket.
- (3) Remove the capscrew that secures the swivel bracket to the floor plate.
- (4) Remove the capscrews and remove the floor plates.

(5) Remove the nuts, washers and capscrews that secure the rods to the lever and remove lever and bracket.

(6) Drive roll pin from lever and shaft and drive shaft from lever and bracket.

(7) Disassemble linkages by removing nuts and capscrews.

*b. Installation.* Installation is reverse procedure of removal.

*c. Adjustment.* Adjust linkages so that control valves will be in neutral position and so there will be sufficient travel to operate valves without bottoming against the valve stop.

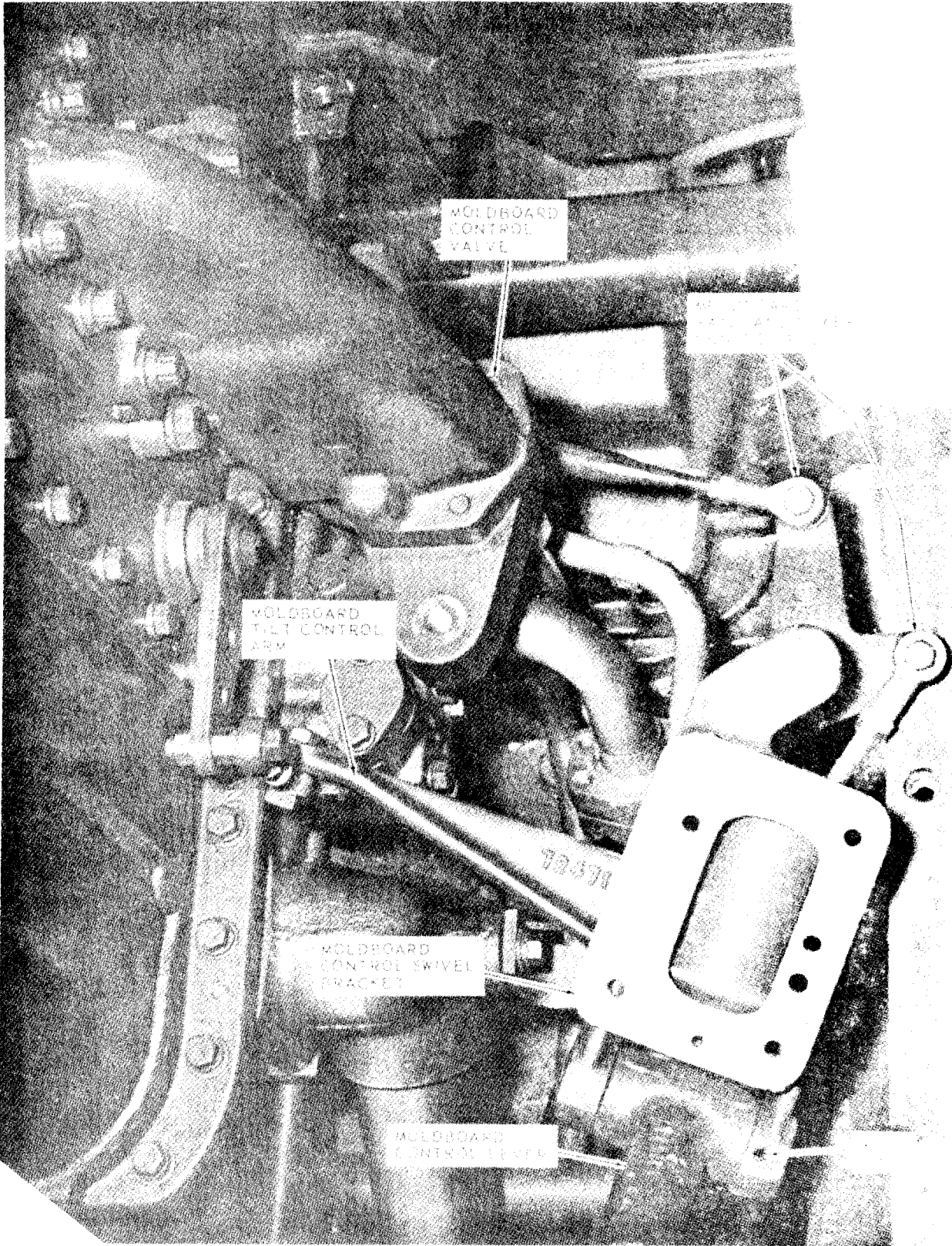

Figure 4-66. Hydraulic control lever and linkage.

## Section XXII. WINCH

### 4-82. General

The power-shift winch is a single drum unit that mounts on the rear face of the tractor bevel gear case, and is driven by a power take off shaft from the tractor transmission. The winch clutches (forward and reverse) and the brake are hydraulically actuated. A separate hydraulic pump supplies power for clutch and brake operation. The control valve is in the winch and is operated by cables which are connected to the two lever control mounted near the operator's seat.

### 4-83. Winch Removal and Installation (Fig. 4-67)

#### a. Removal.

##### NOTE

Clean winch and rear of tractor to prevent entry of dirt into winch or tractor bevel gear case during removal.

##### CAUTION

**To prevent damage to the winch hydraulic pump, the pump must be disconnected from the accessory drive when the tractor is operated with out the winch.**

- (1) Remove cross sheet from rear of tractor.
- (2) Disconnect control cables from hand levers (fig. 3-14).
- (3) Disconnect hydraulic lines from fittings on winch. Insert plate plugs in fittings to prevent entry of dust.

(4) Remove winch transmission case cover.

(5) Install two 7/8-inch UNF x 2-1/2 inch capscrews in holes at each side of winch for lift lugs.

(6) Support the winch with a suitable hoist-weight of winch is approximately 2,600 pounds.

(7) Remove nuts and washers from eight mounting studs (two studs are inside winch).

(8) Remove winch from tractor and install cover over opening in tractor bevel gear case-control cables are removed with winch.

(9) Insert protective plastic plugs in holes in winch.

(10) Install winch transmission case cover.

#### b. Cleaning and Inspection.

(1) Clean all parts with an approved solvent and dry thoroughly.

(2) Inspect winch surfaces for damage or cracks.

(3) Inspect coupling and power takeoff parts for wear or damage.

#### c. Installation.

(1) Before installing winch, apply a liberal coat of heavy type sealant to preform packing in power takeoff bearing carrier.

(2) Adjust control valve spool positions and brake as instructed in paragraph 3-16.

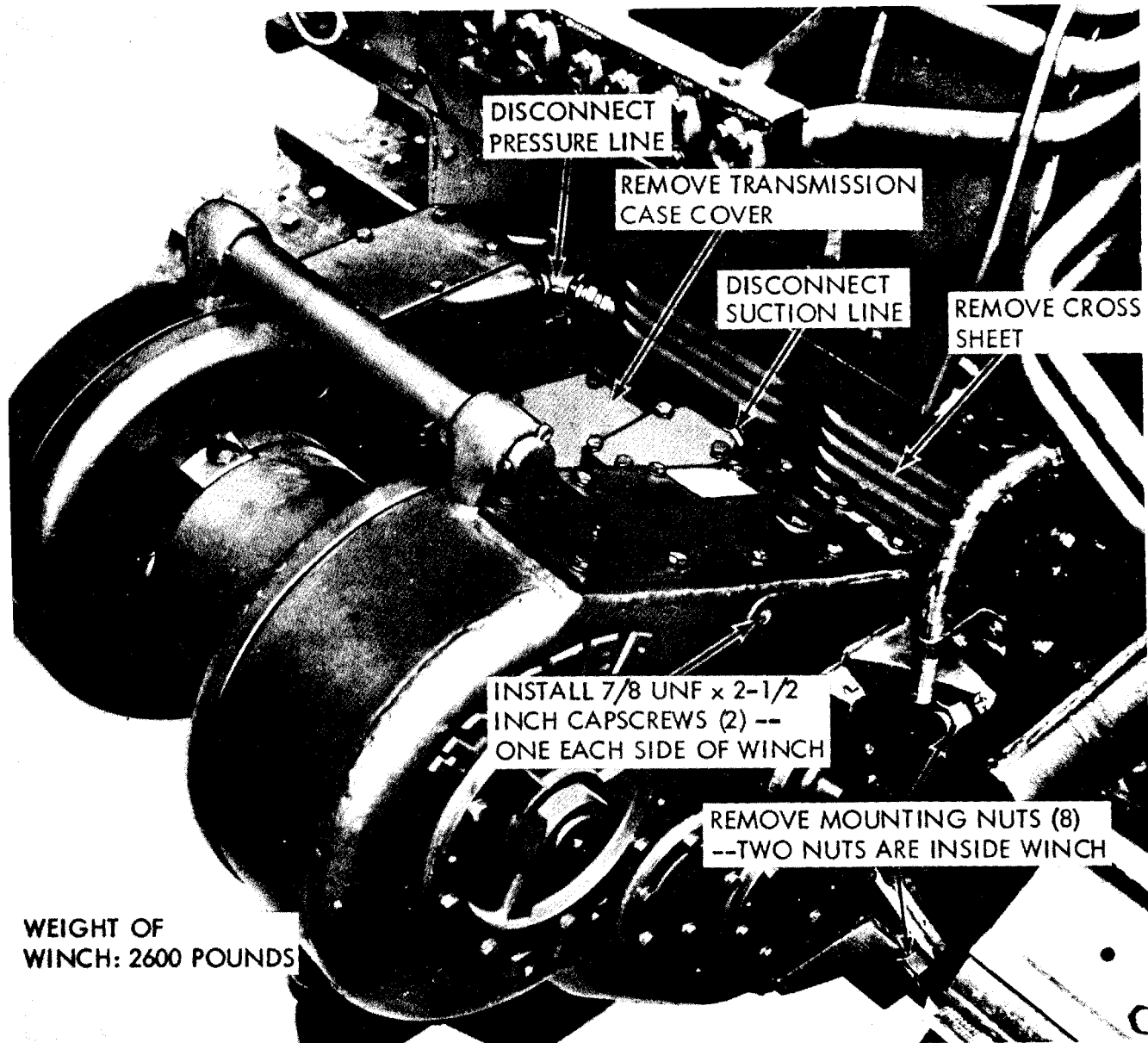

TS 003665

Figure 4-67. Winch, removal and installation.

#### 4-84. Winch Pump

*a. General.* The winch hydraulic pump is mounted on an adapter which is attached to the power takeoff holding. The pump supplies hydraulic pressure for operating the winch controls.

*b. Removal.*

- (1) Remove floor plates covering the pump.
- (2) Refer to figure 4-68 and remove the pump. The adapter may be removed by removing the six attaching nuts.

*c. Cleaning and Inspection.*

- (1) Cover holes in pump to prevent entrance of dirt.
- (2) Clean pump exterior with an approved solvent.
- (3) Inspect drive coupling for damage or wear. Replace if defective.
- (4) Inspect pump exterior for cracks or other damage.

*d. Installation.* Install in reverse order of removal.

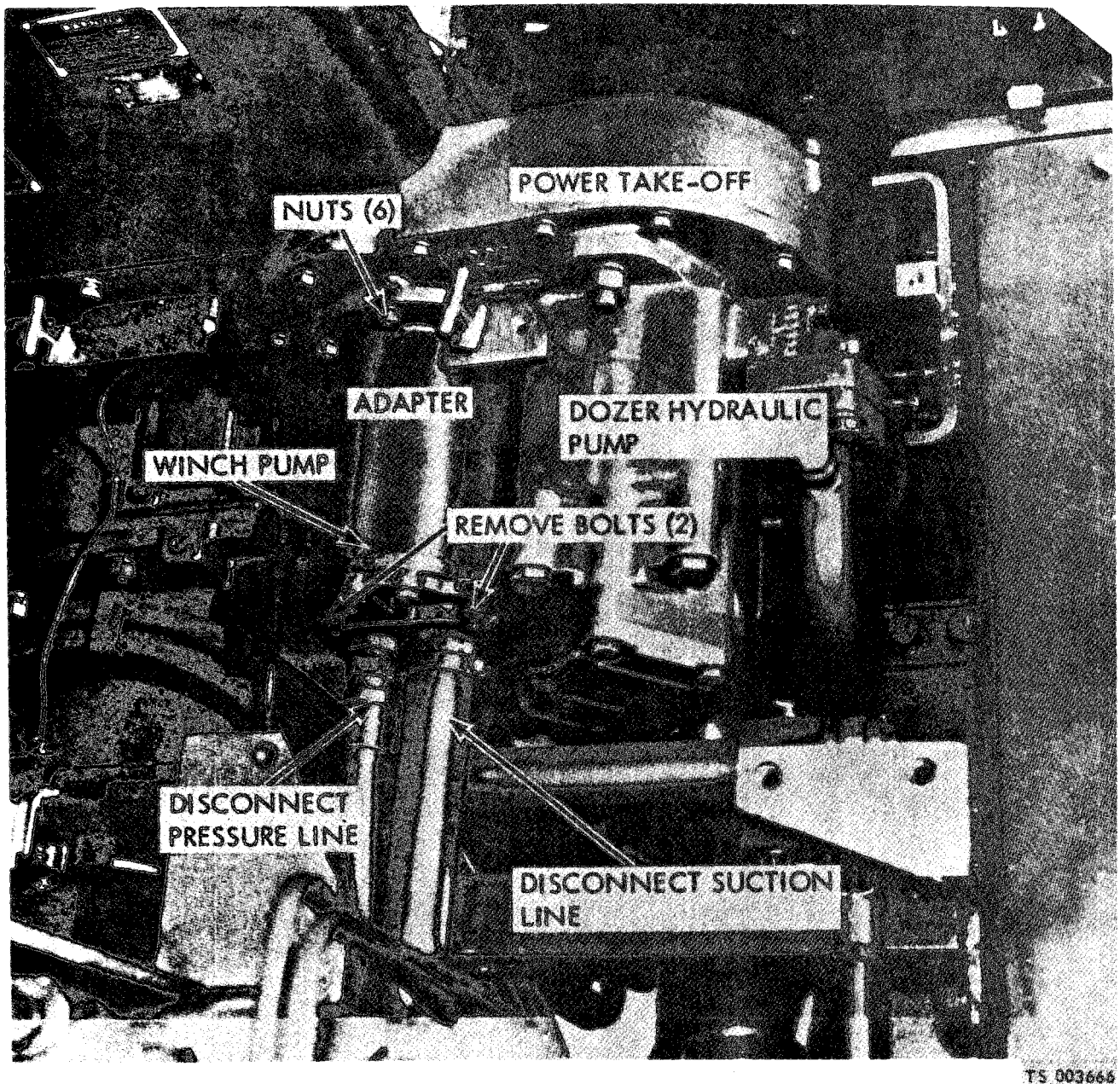

Figure 4-68. Winch pump, removal and installation.

#### 4-85. Winch Brake Band

a. *Removal.* Remove brake band as illustrated in figure 4-69.

b. *Cleaning and Inspection.*

(1) Clean parts with an approved cleaning solvent.

(2) Inspect brake linings for wear or damage. Replace if excessively worn or damaged.

(3) Inspect brake band for cracks or damage. Replace if defective.

c. *Installation.* Install brake band assembly in reverse order of removal.

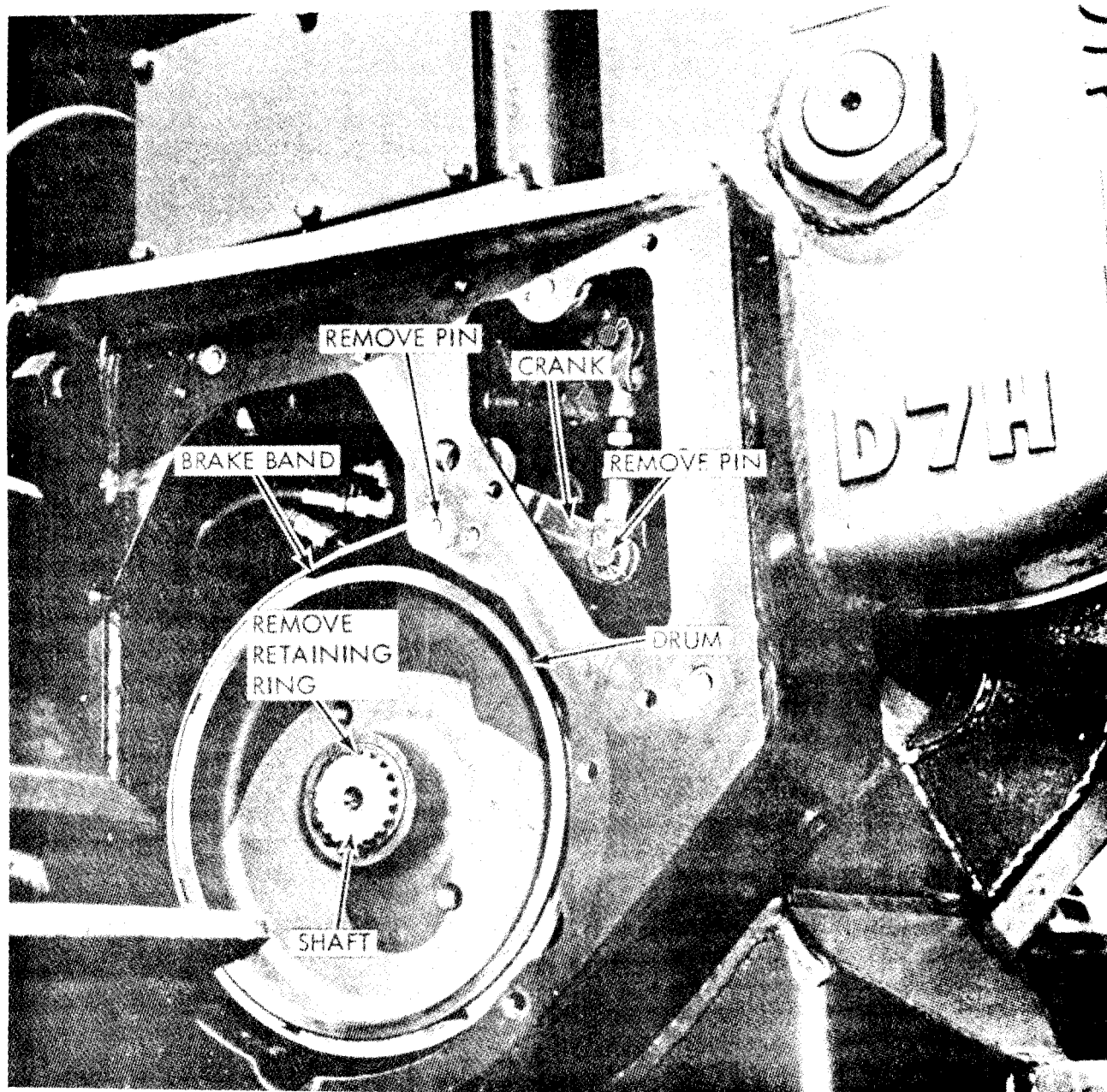

TS 003667

Figure 4-69. Winch brake band, removal and installation.

**4-86. Winch Cable**

The normal operation of the winch is for overwind

operation. See figure 4-70 for changes required for underwind operation.

ATTACHING CABLE TO DRUM -- OVERWIND OR UNDERWIND

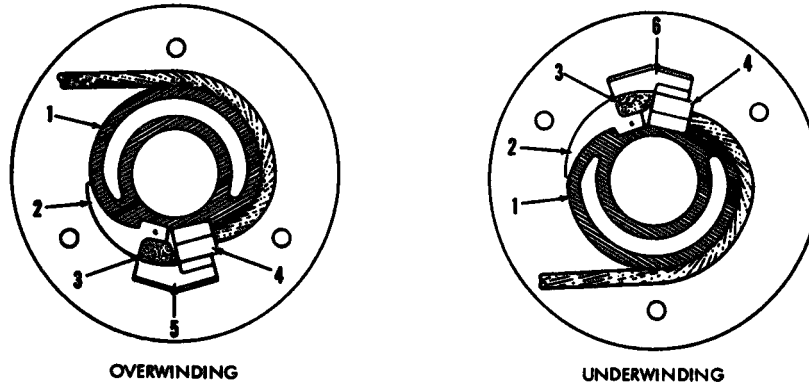

- STEP 1. INSTALL FERRULE (4) AND LOCK IN PLACE WITH FILLER (2) AND FERRULE LOCK (5) FOR OVERWIND, (6) FOR UNDERWIND, USING CAP SCREW (3)
- STEP 2. TO CHANGE FROM OVERWIND TO UNDERWIND, REMOVE CABLE GROOVE FILLER (2) FROM OVERWIND POSITION, INSTALL AS SHOWN FOR UNDERWIND AND TACK WELD IN PLACE

BEVEL GEAR OVERWIND TO UNDERWIND CHANGE

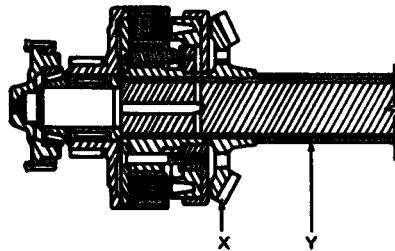

FOR UNDERWIND OPERATION REMOVE BEVEL GEAR "X" AND SPACER "Y" AND REPLACE THEM AS SHOWN

BRAKE BAND CHANGE FROM OVERWIND TO UNDERWIND

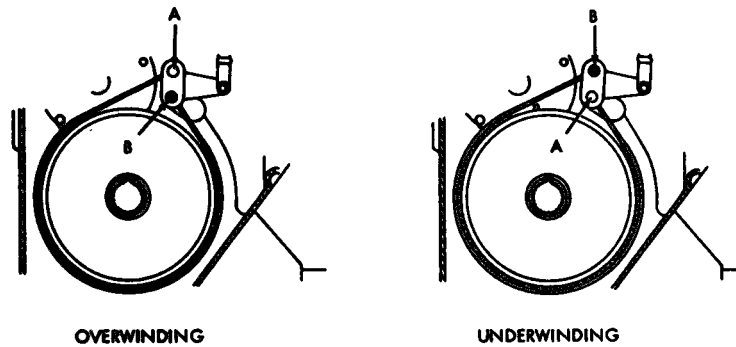

PIN "A," 4-5/8" LONG, WITH COTTER HOLE IN CENTER, HOLDS THE MOVEABLE END OF THE BRAKE BAND

PIN "B," 6-3/8" LONG, WITH TAPPED HOLE IN END, IS THE ANCHOR PIN

TO CHANGE FROM OVERWIND TO UNDERWIND, REMOVE PINS "A" AND "B" FROM POSITIONS SHOWN IN ILLUSTRATION MARKED "OVERWINDING" AND INSERT THEM IN POSITIONS SHOWN IN ILLUSTRATION MARKED "UNDERWINDING"

TS 003668

Figure 4-70. Winch cable installation.



Section XXIII. RIPPER

4-87. General

The ripper is rear mounted and is hydraulically operated by a control lever located to the right of the operator's seat. The ripper has three detachable teeth. One, two, or three teeth may be used as working conditions permit. The hydraulic pump supplies power for ripper raising and lowering operations.

4-88. Ripper Removal and Installation.

a. Removal.

(1) Disconnect hydraulic hoses from junction block (fig. 4-71).

(2) Place a suitable support under beam assembly (fig. 4-72). Be sure that ripper shank tips are not touching ground.

(3) Block rod end of cylinder as shown in figure 4-74, and remove pins and link arm (fig. 4-73). Remove link arm on opposite side in a similar manner.

(4) Pull pin (fig. 4-74) far enough to allow cylinder removal and still support beam assembly. Remove other cylinder in a similar manner.

(5) Place a suitable support under beam assembly close to partially removed pins discussed in step 4 above, then remove pins from both sides of beam assembly.

(6) Drive tractor forward, and remove left and right hand mounting brackets (fig. 4-75).

b. Cleaning and Inspection.

(1) Clean all parts with an approved cleaning solvent and dry thoroughly.

(2) Inspect ripper surfaces for damage.

(3) Inspect hydraulic hoses for breaks, cracks, and kinks. Replace a defective hose.

(4) Inspect tips and protectors for wear and damage. Replace a protective tip or protector.

(5) Inspect all pins for wear, fatigue, and peening.

c. Installation. Install ripper in reverse order of removal.

NOTE

Torque ripper mounting bracket stud nuts to 1500 lb ft.

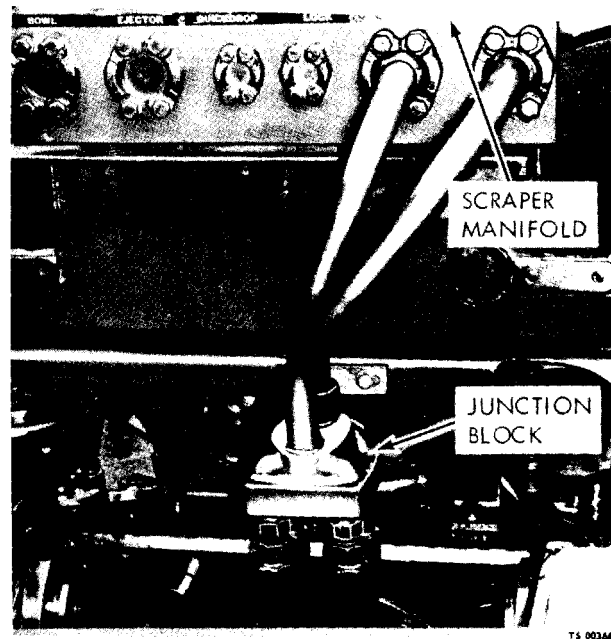

Figure 4-71. Hydraulic hose, removal and installation.

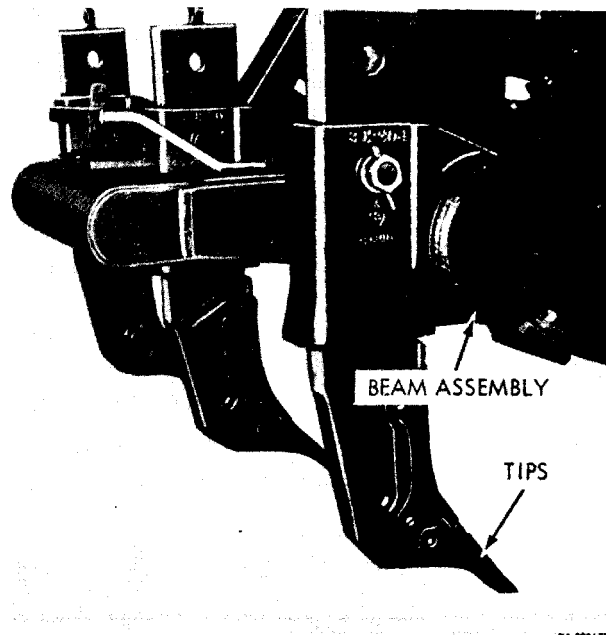
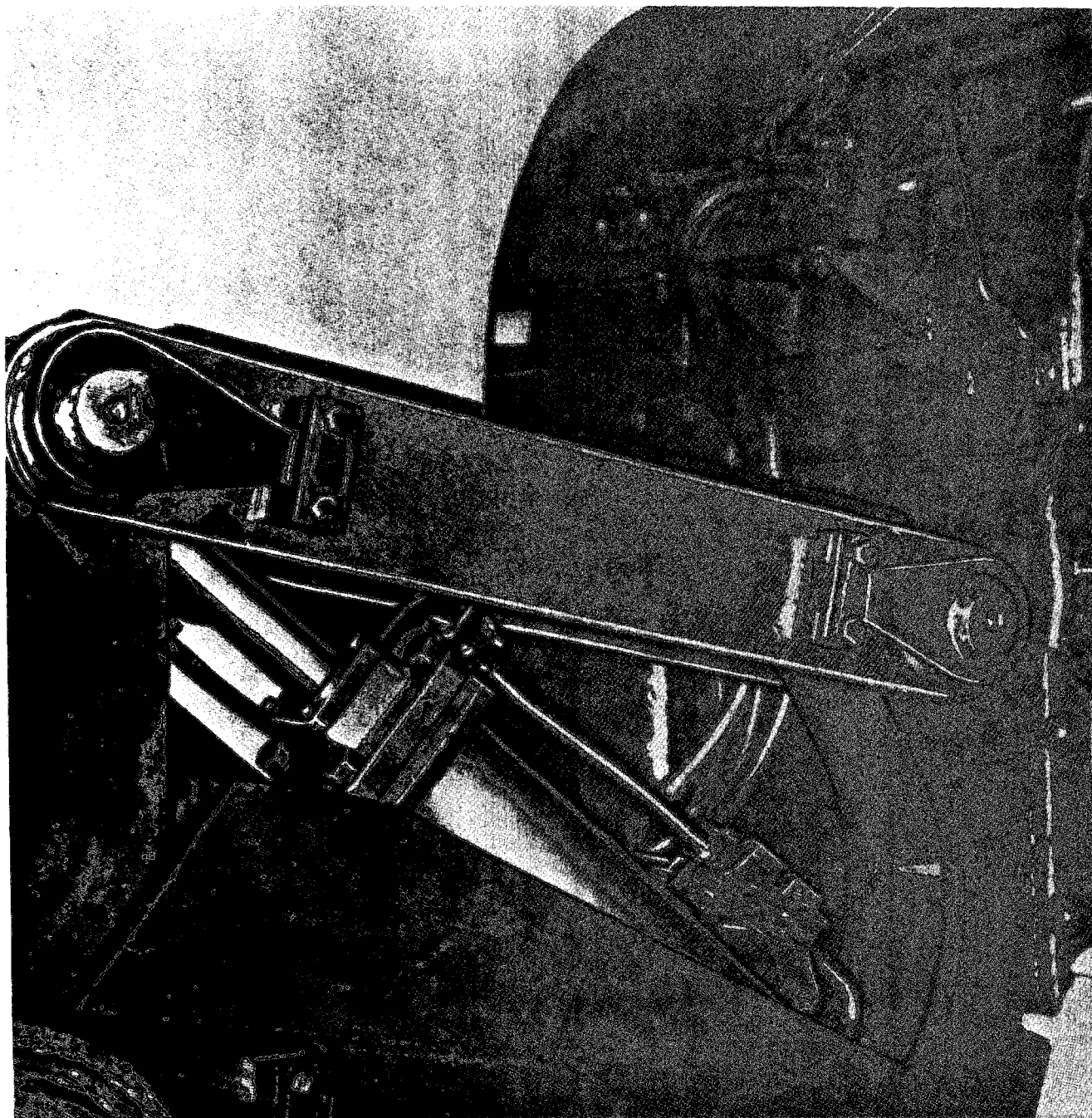
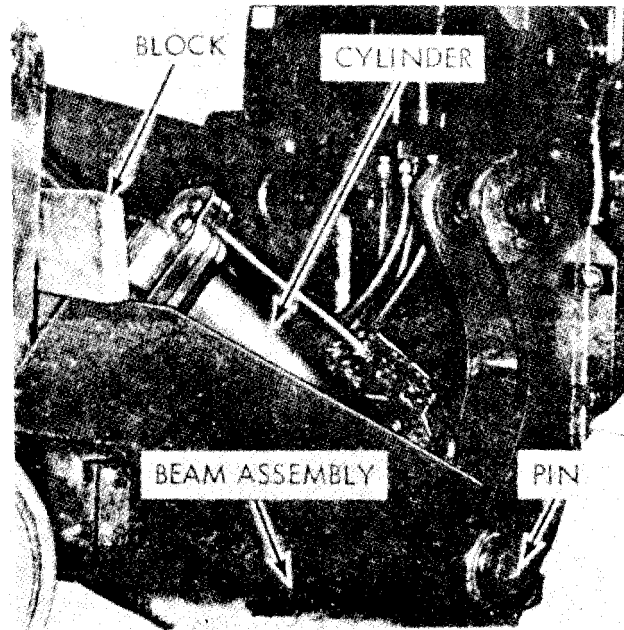

Figure 4-72. Ripper beam and shank.



*Figure 4-73. Link arm, removal and installation.*



**Figure 4-74. Cylinder, removal and installation.**

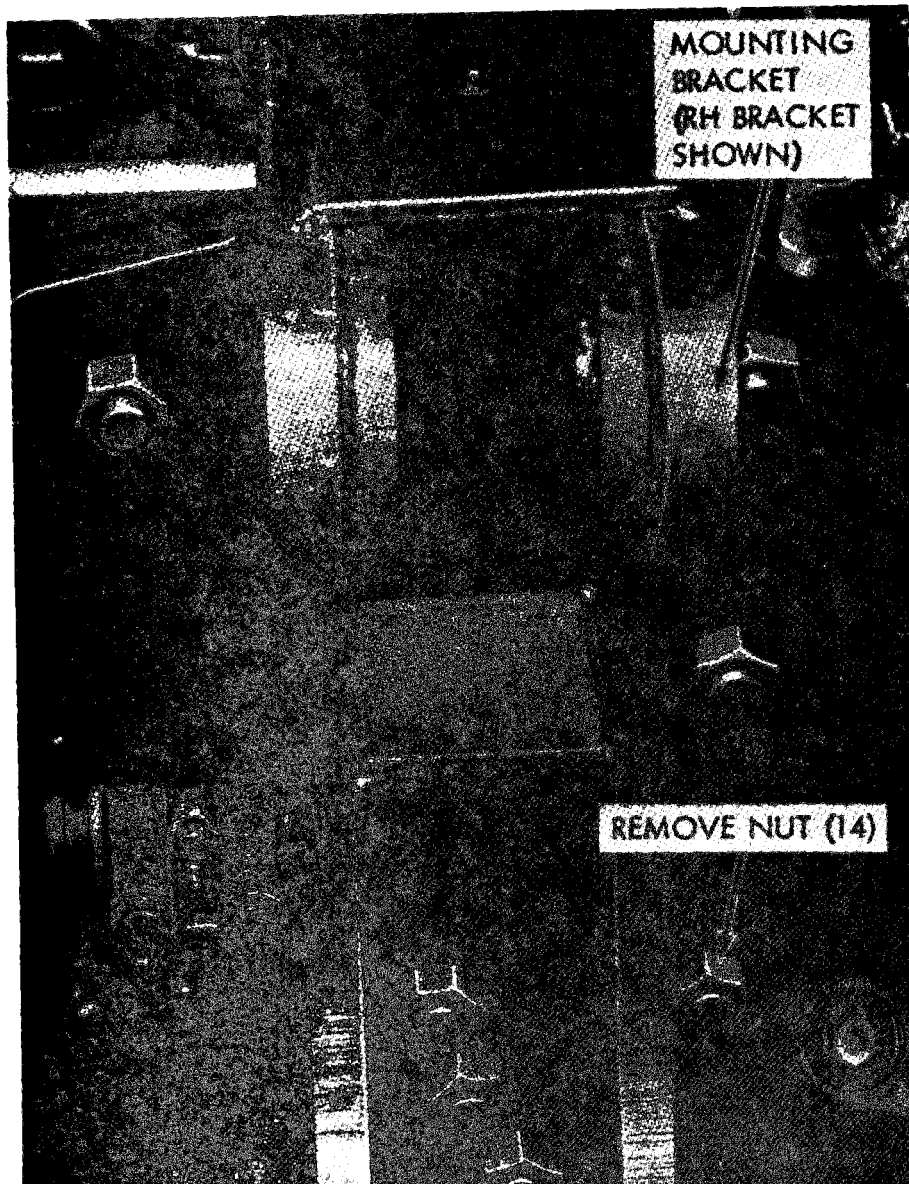

TS 003673

*Figure 4-75. Mounting bracket, removal and installation.*

## APPENDIX A

### REFERENCES

---

#### A-1. Fire Protection

TB 5-4200-200-10 Hand Portable Fire Extinguisher for Army Users

#### A-2. Lubrication

C9100-IL Identification List for Fuel, Lubricants, Oils and Waxes  
 LO 5-2410-214-12-1 and 2 Tractor, Full Tracted, Low Speed: Diesel Engine Driven:  
 Medium Drawbar Pull: Oscillating Track; 78 Inch Gage;  
 Caterpillar Model D7E w/Caterpillar Engine Model D339

#### A-3. Painting

AR 740-1 Storage and Supply Operations  
 AR 746-5 Color Marking of Army Materiel  
 TB 43-0209 Color, Marking and Camouflage Painting of Military  
 Vehicles, Construction Equipment, and Materials  
 Handling Equipment  
 TM 43-0139 Painting Instructions for Field Use

#### A-4. Radio Suppression

FM 11-65 High Frequency Radio Communication

#### A-5. Maintenance

TB 750-651 Use of Antifreeze Solution and Cleaning Compounds in  
 Engine Cooling Systems  
 TM 38-750 Army Maintenance Management System

TM 5-2400-200-ESC Equipment Serviceability Criteria for Tractor, full  
 tracked, low speed, diesel engine driven, all  
 sizes, Allis Chalmers model H16M; Case model 450;  
 Caterpillar models D6, D5A, D6B, D7E, D7F, D8,  
 International Harvester models TD 18-182, TD 20-  
 201 and TD 24-241: various attachments.

#### A-6. Shipment and Storage

TB 740-97-2 Preservation of USAMECOM Mechanical Equipment for  
 Shipment and Storage  
 TM 740-90-1 Administrative Storage of Equipment  
 TM 750-244-3 Destruction of Army Material to Prevent Enemy Use

## APPENDIX B

### MAINTENANCE ALLOCATION CHART

---

#### Section I. INTRODUCTION

#### B-1. General

a. This section provides a general explanation of all maintenance and repair functions authorized at various maintenance levels.

b. Section II designates overall responsibility for the performance of maintenance functions on the identified end item or component and the work measurement time required to perform the functions by the designated maintenance level. The implementation of the maintenance functions upon the end item or component will be consistent with the assigned maintenance functions.

c. Section III Lists the tools and test equipment required for each maintenance function as referenced from Section II. (Not Applicable).

#### B-2. Explanation of Columns in Section II

a. *Column 1. Group Number.* Column 1 lists group numbers to identify related components, assemblies, subassemblies, and modules with their next higher assembly. The applicable groups are listed in the MAC in disassembly sequence beginning with the first group removed.

b. *Column 2. Component/Assembly.* This column contains the noun names of components, assemblies, subassemblies and modules for which maintenance is authorized.

c. *Column 3. Maintenance Functions.* This column lists the functions to be performed on the item listed in Column 2. The maintenance functions are defined as follows:

1. *INSPECT.* To determine serviceability of an item by comparing its physical, mechanical, and/or electrical characteristics with established standards through examination.

2. *TEST.* To verify serviceability and detect incipient failure by measuring the mechanical or electrical characteristics of an item and comparing those characteristics with prescribed standards.

3. *SERVICE.* Operations required periodically to keep an item in proper operating condition, i.e., to clean (decontaminated), to preserve, to drain, to paint, or to replenish fuel, lubricants, hydraulic fluids, or compressed air supplies.

4. *ADJUST.* To maintain within prescribed limits, by bringing into proper or exact position, or by setting the operating characteristics to specified parameters.

5. *ALIGN.* To adjust specified variable elements of an item to bring about optimum or desired performance.

6. *CALIBRATE.* To determine and cause corrections to be made or to be adjusted on instruments or test measuring and diagnostic equipments used in precision measurement. Consists of comparison of two instruments, one of which is a certified standard of known accuracy, to detect and adjust any discrepancy in the accuracy of the instrument being compared.

7. *INSTALL.* The act of emplacing, seating, or fixing into position an item, part, or module (component or assembly) in a manner to allow the proper functioning of an equipment or system.

8. *REPLACE.* The act of substituting a serviceable like type part, sub-assembly, or module (component or assembly) for an un-serviceable counterpart.

9. *REPAIR.* The application of maintenance services (inspect, test, service, adjust, align, calibrate, or replace) or other maintenance actions (welding, grinding, riveting, straightening, facing, remachining or resurfacing) to restore serviceability to an item by correcting specific damage, fault, malfunction, or failure in a part, sub-assembly, module (component or assembly), end item, or system.

10. *OVERHAUL.* That maintenance effort (service/action) necessary to restore an item to a completely serviceable/operational condition as prescribed by maintenance standards (i. e., DMWR) in appropriate technical publications. Overhaul is normally the highest degree of maintenance performed by the Army. Overhaul does not normally return an item to like new condition.

11. *REBUILD.* Consists of those services/actions necessary for the restoration of un-serviceable equipment to a like new condition

in accordance with original manufacturing standards. Rebuild is the highest degree of materiel maintenance applied to Army equipment. The rebuild operation includes the act of returning to zero those age measurements (hours/miles, etc.) considered in classifying Army equipment/components.

d. *Column 4. Maintenance Category.* This column is made up of subcolumns for each category of maintenance. Work time figures are listed in these sub-columns for the lowest level of

maintenance authorized to perform the function listed in Column 3. These figures indicate the average active time required to perform the maintenance function at the indicated category of maintenance under typical field operating conditions.

e. *Column 5. Tools and Equipment.* This column is provided for referencing by code, the common tool sets (not individual tools) special tools, test and support equipment required to perform the designated function.

Section II. MAINTENANCE ALLOCATION CHART

CATERPILLAR MODEL D-7E TRACTOR

(1) Group number	(2) Component / assembly	(3) Maintenance function	(4) Maintenance category					(5) Tools and equipment
			C	O	F	H	D	
01 0100	ENGINE Engine assembly	Inspect Test Replace Repair Overhaul	0.4		1.5 40.0 40.0	40.0 80.0		
0101	Block, cylinder head	Replace Repair			40.0 40.0			
0102	Crankshaft assembly	Replace Rebuild				36.0	50.0	
0103	Flywheel assembly	Replace Repair				16.0 18.0		
0104	Piston, connecting rods	Inspect Replace Repair	4.0				24.0 2.5	
0105	Valves, camshafts, and timing system: Arms, rocker	Adjust Replace Repair			2.5 3.5 3.5			
0106	Engine lubrication system: Breather, filter	Service Replace Repair	0.5	0.2			10.0 10.0	
0109	Pump assembly, oil	Replace Repair					7.0 8.0	
0109	Accessory drive mechanism	Replace Repair						
03 0301	FUEL SYSTEM Fuel injection	Test Service		4.0 4.0				
0302	Fuel pump Pump transfer	Replace Replace Repair		3.0 1.0				
	Pump, fuel injection	Adjust Replace Repair Rebuild			3.0 3.0		24.0 24.0	
0303	Air cleaner	Service Replace	0.1	0.3				
0305	Turbo charger				1.3 8.4			
0306	Tanks, lines, fittings: Cap, strainer, elements, valves	Service Replace		0.3 0.5				

**Section II. MAINTENANCE ALLOCATION CHART  
CATERPILLAR MODEL D-7E TRACTOR**

(1) Group number	(2) Component assembly	(3) Maintenance function	(4) Maintenance category					(5) Tools and equipment
			C	O	F	H	D	
0306	Tanks, lines, fittings—Continued							
	Lines, fuel .....	Replace .....	.....	.. 2.0				
		Repair .....	.....	.. 2.0				
	Tank, fuel .....	Inspect .....	0.1					
		Service .....	0.5					
		Replace .....	.....		.. 3.5			
		Repair .....	.....		.. 6.5			
0308	Engine speed governor .....	Replace .....	.....		.. 6.0			
		Repair .....	.....		.. 24.0			
0309	Fuel filters .....	Service .....	0.1					
		Replace .....	.....	.. 0.5				
04	<b>EXHAUST SYSTEM</b>							
0401	Muffler and pipes .....	Inspect .....	0.1					
		Replace .....	0.5					
05	<b>COOLING SYSTEM</b>							
0501	Radiator:							
	Radiator assembly .....	Inspect .....	0.2					
		Service .....	0.1					
		Replace .....	.....		.. 4.0			
		Repair .....	.....		.. 16.0			
0503	Water manifolds, header, thermostats and housing gaskets:							
	Thermostat flow control .....	Test .....	.....	.. 1.0				
		Replace .....	.....	.. 0.5				
0504	Water pump .....	Inspect .....	0.1					
		Replace .....	.....		.. 1.0			
		Repair .....	.....		.. 3.0			
0505	Fan assembly .....	Service .....	0.5					
		Replace .....	.....		.. 1.0			
	<b>ELECTRICAL SYSTEM</b>							
06	Generator:							
0601	Belt, drive .....	Adjust .....	0.5					
		Replace .....	.....		.. 0.8			
	Generator assembly .....	Inspect .....	0.1					
		Replace .....	.....		.. 4.0			
		Rebuild .....	.....			.. ..	.. 6.0	
0602	Generator regulator .....	Inspect .....	0.1					
		Repair .....	.....		.. 0.2			
0603	Starting motor:							
	Starting assembly .....	Test .....	.....	.. 0.2				
		Replace .....	.....	.. 1.5				
		Repair .....	.....		.. 8.0			
		Rebuild .....	.....			.....	10.0	
0607	Instrument or engine control panel:							
	Gages, switches, lights, lamps, panel, control .....	Inspect .....	.....	.. 1.2				
		Replace .....	.....	.. 1.6				
		Repair .....	.....	.. 3.0				
0609	Lights:							
	Lights, wiring .....	Overhaul .....	.....	.. 4.0				
		Rebuild .....	.....	.. 4.0				
0612	Batteries, storage							
	Batteries .....	Test .....	.....	.. 0.1				
		Service .....	.....	.. 0.3				
		Replace .....	.....	.. 0.5				
0613	Chassis wiring harness .....	Inspect .....	.....	.. 0.3				
		Replace .....	.....		.. 4.2			
		Repair .....	.....	.. 2.0				



Section II. MAINTENANCE ALLOCATION CHART

CATERPILLAR MODEL D-7E TRACTOR

(1) Group number	Component assembly	(3) Maintenance function	(4) Maintenance category					(5) Tools and equipment
			C	O	F	H	D	
07	TRANSMISSION							
0708	Torque converter or fluid coupler torque divider	Replace	...			16.0		
		Repair	...			16.0		
		Overhaul	...				20.0	
0710	Transmission assembly	Inspect	...	0.3				
		Service	0.5					
		Replace	...			19.5		
		Repair	...			24.5		
		Overhaul	...				30.0	
	Linkage	Adjust	...		1.5			
		Replace	...		3.5			
		Repair	...		2.5			
0721	Coolers, pumps:							
	Cooler oil	Replace	...	1.6				
		Repair	...		2.5			
	Filters, breather	Service	0.5					
		Replace	...	0.2				
	Hose, fittings	Inspect	...	0.1				
		Replace	...	0.5				
	Pump, hydraulic	Inspect	...	0.2				
		Test	...			3.4		
		Replace	...	10.0				
		Repair	...			4.0		
	Strainer	Service	...	0.1				
		Replace	...		0.8			
09	PROPELLER AND PROPELLER SHAFT							
0900	Propeller shafts:							
	Joint, universal	Inspect	1.5					
		Replace	...		2.5			
		Repair	...		2.5			
11	REAR AXLE							
1103	Final drive	Inspect	...	0.2				
		Service	...	0.5				
		Replace	...			50.0		
		Repair	...			50.0		
		Rebuild	...				50.0	
1124	Steering brake, differential and planetary drive	Test	...	0.5				
		Replace	...			50.0		
		Repair	...			50.0		
13	TRACKS							
1301	Suspension system:							
	Bar equalizer	Inspect	...		1.5			
		Replace	...			3.0		
		Repair	...			4.0		
	Frame, track	Inspect	...		0.2			
		Replace	...			24.0		
		Repair	...			30.0		
		Rebuild	...				30.0	
1302	Tracks support rollers and brackets	Inspect	...	0.5				
		Replace	...		16.0			
		Repair	...		16.0			
1303	Track idlers and brackets:							
	Adjuster, hydraulic track and bracket idler	Inspect	...	0.5				
		Service	...	2.0				
		Replace	...		10.0			
		Repair	...		10.0			

Section II. MAINTENANCE ALLOCATION CHART

CATERPILLAR MODEL D-7E TRACTOR

(1) Group number	(2) Component assembly	(3) Maintenance function	(4) Maintenance category					(5) Tools and equipment
			C	O	F	H	D	
14 1403	<b>STEERING</b> Steering brakes: Brakes, steering  Clutch, steering  Controls and linkage	Replace Repair Replace Repair Inspect Adjust Replace Repair Replace Repair					16.0 24.0 42.0 42.0	
1411	Hoses, lines, fittings	Inspect Replace Repair Repair			3.5 3.5 3.0 5.0			
18 1801	<b>BODY CAB, HOOD AND HULL</b> Body, cab, hood and hull assemblies: Fender, hood panel guards	Inspect Replace Repair Replace Repair		0.3 1.8 2.4 2.5 4.1				
1806	Seats	Replace Repair		2.5 4.1				
20 2001	<b>WINCH</b> Winch assembly: Brake band assembly  Control assembly  Cable, winch  Winch assembly	Adjust Replace Repair Install Replace Inspect Install Inspect Service Install Replace Repair	0.5	2.0 2.0 3.1 3.1 0.1 1.0 0.1 0.5 10.0	3.1			
24 2401	<b>HYDRAULIC SYSTEM</b> Pump and pump drive	Inspect Replace Repair	0.1	2.1				
2402	Manifold and/or control valves: Valve, scraper  Valve, tilt	Replace Repair Replace Repair			1.0 4.0 1.0 4.5			
2403	Hydraulic controls and/or manual controls: Levers  Linkage	Replace Repair Inspect Adjust Replace Repair		1.0 1.0 0.2 1.2 2.1 2.2				
2406	Strainers, filters, hose pipe fittings tubing: Filter strainer	Service Replace Inspect	0.1	0.3				
2407	Hydraulic cylinders	Replace Repair			5.3			
2408	Liquid tank or reservoir	Inspect Service Replace Repair Replace Repair	0.1	0.5 4.5 8.0				
		Replace Repair			2.1 2.2			

Change 1

Section II. MAINTENANCE ALLOCATION CHART

CATERPILLAR MODEL D-7E TRACTOR

(1) Group number	(2) Component / assembly	(3) Maintenance function	(4) Maintenance category					(5) Tools and equipment
			C	O	F	H	D	
74	EARTH MOVING EQUIPMENT COMPONENTS							
7435	Moldboard assembly: Bulldozer	Service Adjust	0.2 0.2					
7436	Lift arms and pivot assemblies	Inspect Service Align Replace	0.1 0.2 0.2 4.0					
7440	Scarifier assembly: Housing	Inspect Replace Repair	0.2 2.0 2.0					
7465	Ripper arrangement: Ripper	Inspect Service Adjust Replace Repair Overhaul Inspect	 0.1 0.2     		0.1			
	Tips and projectors			0.8	24.0 30.0			
76	FIRE FIGHTING EQUIPMENT COMPONENTS			0.2				
7638	Fire extinguishers .....	Inspect .....	.....	.01				
		Replace .....	0.2					

\*SUBCOLUMNS ARE AS FOLLOWS:  
F—DIRECT SUPPORT;

C—OPERATOR/CREW;  
H—GENERAL SUPPORT;

O—ORGANIZATIONAL;  
D—DEPOT

\* INDICATES WT/MH REQUIRED

# APPENDIX C

## BASIC ISSUE ITEMS LIST AND ITEMS TROOP INSTALLED OR AUTHORIZED

### Section I. INTRODUCTION

**C-1. Scope**

This appendix lists items required by the operator for operation of the Caterpillar tractor.

**C-2. General**

This list is divided into the following sections:

*a. Basic Issue Items List - Section II.* Not applicable.

*b. Items Troop Installed or Authorized List - Section III.* A list of items in alphabetical sequence, which at the discretion of the unit commander may accompany the Caterpillar tractor. These items are NOT SUBJECT TO TURN-IN with the tractor when evacuated.

**C-3. Explanation of Columns**

The following provides an explanation of columns in the tabular list of Basic Issue Items List, Section II, and Items Troop Installed or Authorized, Section III.

*a. Source, Maintenance and Recoverability Code (SM12).* Not applicable.

*b. National Stock Number.* This column indicates the National stock number assigned to the item and will be used for requisitioning purposes.

*c. Description.* This column indicates the Federal item name and any additional description of the item required.

*d. Unit of Measure (U/M).* A two character alphabetic abbreviation indicating the amount or quantity of the item upon which the allowances are based, e.g., ft. ea. pr, etc.

*e. Quantity Furnished with Equipment (BIIL).* Not applicable.

*f. Quantity Authorized ( Items Troop Installed or Authorized).* This column indicates the quantity of the item authorized to be used with the equipment.

### Section III. ITEMS TROOP INSTALLED OR AUTHORIZED LIST

National Stock Number	Description	U / M	QTY AUTH
7510-00-889-3494	BINDER, LOOSE LEAF: U. S. ARMY Equipment Logbook	EA	1
7520-00-559-9618	CASE: Maintenance and Operational manuals, cotton duck, water-repellent, mildew-resistant, MIL-B-11743B	EA	1
7150-00-244-0359	CONTAINER, PLASTIC: Logbook binder	EA	1

INDEX

	Paragraph	Page		Paragraph	Page
<b>A</b>					
Administrative storage	1-7	1-1	Radio interference suppression	4-10	4-9
Air cleaner	3-4	3-4	Ripper	4-87	4-98
Alternator for generator replacement	4-44	4-53	Steering clutches and brakes	4-56	4-66
Ammeter and instrument panel switches	4-47	4-57	Thermostats	4-36	4-43
<b>B</b>					
Basic issue items and troop installed or authorized list	1-5	1-1	Track and track frames	4-61	4-72
Batteries	4-50	4-60	Transmission torque divider and steering clutches	4-52	4-62
Batteries and cables	3-12	3-14	Troubleshooting	3-3	3-2
Breather and oil filter	4-19	4-21	Winch	4-82	4-93
Bulldozer	3-17	3-17	Generator	4-43	4-52
Bulldozer blade assembly	4-74	4-79	Generator belt adjustment	3-11	3-14
<b>C</b>					
Cap assembly	4-39	4-48	Generator regulator	4-45	4-55
Controls and instruments	2-2	2-1	Glow plugs	4-32	4-37
Crankcase guards	4-67	4-75	Governor controls	4-21	4-24
<b>D</b>					
Dashlights	4-48	4-58	Guards, track roller frame and sprocket	4-65	4-73
Description of tractor	1-8	1-1	<b>H</b>		
Destruction of Army materiel to prevent enemy uses	1-6	1-1	Headlights and floodlights	4-49	4-60
Detailed lubrication information	4-9	4-3	Hoses, lines and fittings	4-35	4-42
Difference in models	1-10	1-6	Hydraulic control lever and linkage	4-81	4-91
Disconnect switch	4-51	4-60	Hydraulic system-dozer	3-15	3-15
Dismantling for movement	4-4	4-3	Hydraulic system hose, lines, fittings	4-79	4-84
Dozer hydraulic pump	4-78	4-82	<b>I</b>		
Dozer, hydraulic tank and filter	4-80	4-89	Information and data plates	1-1	1-1
<b>E</b>					
Engine upper guard			Inspecting and servicing equipment	4-1	4-1
Engine valve mechanism	4-68	4-75	Installation of separately packed items	4-2	4-1
Equipment conversion	4-14	4-13	Interference suppression components	4-11	4-9
Equipment serviceability criteria	4-3	4-3	<b>M</b>		
<b>F</b>					
Fan belts	3-10	3-14	Maintenance forms and records	1-2	1-1
Fan belts and generator belts	4-40	4-48	Maintenance repair parts	4-7	4-3
Fan and fan guard	4-41	4-50	Muffler and exhaust pipe	3-5	3-5
Fenders	4-69	4-77	<b>O</b>		
Final fuel filter	4-31	4-36	Oil cooler	4-18	4-20
Floors	4-70	4-77	Oil fitter and base	4-17	4-17
Fuel filters	3-7	3-9	Operation in deep mud or water	2-9	2-15
Fuel injection pumps	4-26	4-30	Operation in dusty or sandy area	2-8	2-15
Fuel injection valves	4-25	4-30	Operation in extreme cold	2-6	2-14
Fuel primer	4-27	4-33	Operation in extreme heat	2-7	2-15
Fuel tank	3-6	3-7	Operation in high altitudes	2-12	2-15
Fuel tank and lines	4-29	4-34	Operation in salt water areas	2-11	2-15
Fuel transfer pump	4-28	4-33	Operation of equipment	2-4	2-8
<b>G</b>					
Gages	4-22	4-25	Operation under rainy or humid conditions	2-10	2-15
<b>General:</b>					
Bulldozer and scarifiers	4-73	4-79	<b>P</b>		
Cooling system	4-33	4-38	Preventive maintenance checks and services	3-2	3-1
Electrical system	4-42	4-51	Primary fuel filter	4-30	4-36
Engine lubrication system	4-16	4-15	Priming the fuel system	3-8	3-11
Engine valve mechanism	4-14	4-13	Push arms	4-75	4-80
Frame and guards	4-64	4-73	<b>R</b>		
Fuel system	4-24	4-27	Radiator	3-9	3-12
Hydraulic system bulldozer	4-77	4-82	Radiator guard	4-34	4-40
Lubrication information	4-8	4-3	Radiator sealed pressure overflow unit (Serial No. 75E 1 through 75 E1300)	4-37	4-46
Operating instruction	2-1	2-1	Radiator sealed pressure overflow unit (serial No. 75 E1301-up)	4-38	4-46
Preventive maintenance checks and services	3-1	3-1	Reinstallation after movement	4-5	4-3
			Replacement of suppression components	4-12	4-12

	Paragraph	Page		Paragraph	Page
Reporting of errors . . . . .	1-3	1-1	Tabulated data . . . . .	1-9	1-1
Ripper . . . . .	3-19	3-19	Testing of radio interference sup pression components . . . . .	4-13	4-12
Ripper removal and installation . . . . .	4-83	4-93	Thermostat . . . . .	4-36	4-43
S			Time totalizing meter (hourmeter) . . . . .	4-23	4-26
Scarifiers . . . . .	3-18;4-76	3-18;4-81	Tool box . . . . .	4-71	4-77
Scope . . . . .	1-1	1-1	. . . . .Track adjustment . . . . .	4-63	4-72
Seat . . . . .	4-72	4-78	Track rollers and idlers . . . . .	4-62	4-72
Special tools and equipment . . . . .	4-6	4-3	Track roller guards . . . . .	4-66	4-73
Sprocket hub bearings . . . . .	4-59	4-70	Track . . . . .	3-14	3-14
Starting . . . . .	2-3	2-7	Transmission filters . . . . .	4-55	4-66
Starting motor . . . . .	4-46	4-56	Transmission hoses, lines, fittings . . . . .	4-54	4-64
Steering clutch brake adjustment . . . . .	4-57	4-68	Transmission pump . . . . .	4-53	4-62
Steering clutch linkage adjustment . . . . .	4-58	4-69	Transmission, torque converter and . . . . .		
Stopping the tractor . . . . .	2-5	2-14	steering clutches hydraulic system . . . . .	3-13	3-14
T			Turbocharger oil lines . . . . .	4-20	4-23
Table 1-1. Information plate and . . . . .			V		
transfer . . . . .		1-3	Valve clearance adjustment . . . . .	4-15	4-14
Table 3-1. Preventive maintenance . . . . .			W		
checks and services: operator and . . . . .		3-1	Washing final drive compartments . . . . .	1-60	4-71
crew . . . . .			Winch . . . . .	3-16	3-15
Table 3-2. Troubleshooting, operator . . . . .			Winch brake band . . . . .	4-85	4-95
and crew . . . . .		3-2	Winch cable . . . . .	4-86	4-96
Table 4-1. Preventive maintenance . . . . .			Winch pump . . . . .	4-84	4-94
checks and services, organizational . . . . .		4-4	Winch removal and installation . . . . .	4-83	4-93
maintenance . . . . .					
Table 4.2 Troubleshooting, organ- . . . . .		4-6			
izational maintenance . . . . .					

**By Order of the Secretary of the Army:**

**Official:**  
**VERNE L. BOWERS**  
*Major General, United States Army,*  
*The Adjutant General.*

**FRED C. WEYAND**  
*General, United States Army,*  
*Chief of Staff.*

**Distribution:**

To be distributed in accordance with DA Form 12-25B (qty rqr block no. 477),  
Operator requirement for Tractor, Tracked, Medium.

RECOMMENDED CHANGES TO EQUIPMENT TECHNICAL PUBLICATIONS



THEN... JOT DOWN THE DOPE ABOUT IT ON THIS FORM, CAREFULLY TEAR IT OUT, FOLD IT AND DROP IT IN THE MAIL!

SOMETHING WRONG WITH THIS PUBLICATION?

FROM: (PRINT YOUR UNIT'S COMPLETE ADDRESS)

Your mailing address

DATE SENT

Date you filled out this form

PUBLICATION NUMBER

TM 5-2410-214-12

PUBLICATION DATE

30 January 82

PUBLICATION TITLE

Tractor, Full Tracked, Low Speed

BE EXACT... PIN-POINT WHERE IT IS

PAGE NO.	PARA-GRAPH	FIGURE NO.	TABLE NO.
3-2			3-2
A-1	A-1		

IN THIS SPACE TELL WHAT IS WRONG AND WHAT SHOULD BE DONE ABOUT IT:

*Under Malfunction 2, there must be a step missing. Instructions are unclear.*

*Cannot find publication referenced — TB 4200-200-10.*

**SAMPLE**

PRINTED NAME, GRADE OR TITLE, AND TELEPHONE NUMBER

*E.I. Speck, Sgt., 211-0001*

SIGN HERE:

*Sgt. E.I. Speck*

DA FORM 2028-2  
1 JUL 78

PREVIOUS EDITIONS ARE OBSOLETE.

P.S.—IF YOUR OUTFIT WANTS TO KNOW ABOUT YOUR RECOMMENDATION MAKE A CARBON COPY OF THIS AND GIVE IT TO YOUR HEADQUARTERS.

TEAR ALONG PERFORATED LINE



RECOMMENDED CHANGES TO EQUIPMENT TECHNICAL PUBLICATIONS



THEN... JOT DOWN THE DOPE ABOUT IT ON THIS FORM, CAREFULLY TEAR IT OUT, FOLD IT AND DROP IT IN THE MAIL!

SOMETHING WRONG WITH THIS PUBLICATION?

FROM: (PRINT YOUR UNIT'S COMPLETE ADDRESS)

DATE SENT

PUBLICATION NUMBER TM 5-2410-214-12	PUBLICATION DATE 30 January 82	PUBLICATION TITLE Tractor, Full Tracked, Low Speed
--	-----------------------------------	---

BE EXACT... PIN-POINT WHERE IT IS				IN THIS SPACE TELL WHAT IS WRONG AND WHAT SHOULD BE DONE ABOUT IT:
PAGE NO.	PARA-GRAPH	FIGURE NO.	TABLE NO.	

TEAR ALONG PERFORATED LINE

PRINTED NAME, GRADE OR TITLE, AND TELEPHONE NUMBER	SIGN HERE:
--	------------

DA FORM 2028-2 (1 JUL 79)

PREVIOUS EDITIONS ARE OBSOLETE.

P.S.--IF YOUR OUTFIT WANTS TO KNOW ABOUT YOUR RECOMMENDATION MAKE A CARBON COPY OF THIS AND GIVE IT TO YOUR HEADQUARTERS.

FILL IN YOUR  
UNIT'S ADDRESS

FOLD BACK

DEPARTMENT OF THE ARMY

OFFICIAL BUSINESS

Commander  
US Army Tank-Automotive Command  
ATTN: DRSTA-MB  
Warren, MI 48090

TEAR ALONG PERFORATED LINE

